

# M-2: The Emergence of Quarks/Anti-Quarks

**Naohiro Ozawa**

**Mailing address:**

**Naohiro Ozawa**

**1-8-27, Sakuraoka, Tyuuou-ku, Saitama City, Saitama-kenn, Japan**

**338-0005**

**Tel: +81-048-854-4111**

**Fax: +81-048-854-4111**

**Email: [1148ldfp@jcom.home.ne.jp](mailto:1148ldfp@jcom.home.ne.jp)**

**Short title: Emergence of Quarks and Anti-Quarks**

**Key words:**

**Formation of quarks/anti-quarks**

**Vacuum phase transition**

**Electric charges**

**The structure of quarks**

**Black-holes**

**PACS Classification numbers:**

**11.30.Fs Global symmetries**

**14.60.-z Leptons**

**14.65.-q Quarks**

**26.35.+c Bigbang nucleo-synthesis**

**26.35.+c Structural and shielding materials**

## Abstract

In clarifying the entirety of the universe, the most important processes are the emergence of the universe and the formation of quarks/anti-quarks. The entirety of the universe has emerged in a causal and consecutive manner. According to the Standard Model, from the dawn of the universe, particles such as 3 pairs of neutrinos ( $\nu_\mu/\bar{\nu}_\mu$ ,  $\nu_e/\bar{\nu}_e$ ,  $\nu_\tau/\bar{\nu}_\tau$ ) and 6 pairs of quarks ( $u/\bar{u}$ ,  $d/\bar{d}$ ,  $s/\bar{s}$ ,  $c/\bar{c}$ ,  $b/\bar{b}$ ,  $t/\bar{t}$ ) suddenly emerged with different components not due to causality but due to "vacuum phase transitions" with no space existing in the universe. In this research paper, we must first assume that quarks/anti-quarks are formed inextricably linked with the organization of space-time/anti-space-time and in cooperation with 2 pairs of neutrinos ( $\nu_\mu/\bar{\nu}_\mu$ ,  $\nu_e/\bar{\nu}_e$ ) in the acting of the "strong interaction" and "weak interaction." We must also assume that quarks/anti-quarks are the main body that composes the  $\pi$ -on group ( $\pi^+$ ,  $\pi^-$ ,  $\pi^\pm$ ,  $\pi^0$ ) and the nucleon group ( $p$ ,  $\bar{p}$ ,  $n$ ,  $\bar{n}$ ), and that they play the leading role to compose not only 120 types of atomic nuclei, but also all the particles/antiparticles that exist in the entire universe. In other words, the formed quarks/anti-quarks must clear any and all problems in the above series without any contradictions. This research paper will make clear details such as the fact that only 2 pairs of quarks ( $u/\bar{u}$ ,  $d/\bar{d}$ ) were formed; that in the entirety of the universe, only these 2 pairs of

quarks were given electrical charges; and that the raw materials of space-time/anti-space-time are the same as quarks/anti-quarks.

## Introduction

The Standard Model believes that fundamental particles such as neutrinos and quarks emerged immediately after the second vacuum phase [1] transition  $10^{-36}$  seconds after the emergence of the universe. However, "vacuum phase transitions" are not causal phenomena, they are accidental ones. Therefore, according to this theory, the 3 pairs of neutrinos ( $\nu_\mu/\bar{\nu}_\mu$ ,  $\nu_e/\bar{\nu}_e$ ,  $\nu_\tau/\bar{\nu}_\tau$ ) and the 6 pairs of quarks ( $u/\bar{u}$ ,  $d/\bar{d}$ ,  $c/\bar{c}$ ,  $s/\bar{s}$ ,  $b/\bar{b}$ ,  $t/\bar{t}$ ) [2] emerged not causally but accidentally. Hence, it is exceedingly vague how the universe then connected its sequential development through "strong interaction" [2] and "weak interaction" [2], which are causal phenomena, to form nucleons and extremely minute atomic nuclei.

The previous research paper made clear how pre-space-time and neutrinos were first formed through the "emergence force of the universe," which is the first physical force. In this research paper, half of the entirety of the remaining 4 entities ("positive time," "negative time," "positive space," and "negative space") have been separated into "dynamic" and "static" entities respectively as the third work exhibited by the "emergence force of the universe." Next, it will be made clear that quarks/anti-quarks and space-time/anti-space-time were constructed

by the "formation force of quarks," which is the second force. It will be made clear that at this time, the materials of space-time/anti-space-time did not have electrical charges and only the materials of quarks/anti-quarks had electrical charges. Furthermore, it will be made clear that the structures of quarks/anti-quarks are not single components as the Standard Model believes but are instead composite particles. Also, the belief that 6 pairs of quarks/anti-quarks emerged will be disproven by making clear that only 2 pairs ( $\mathbf{u}/\bar{\mathbf{u}}$ ,  $\mathbf{d}/\bar{\mathbf{d}}$ ) emerged. One of the most important concepts in the development of the universe is that the 2 pairs of quarks formed here ( $\mathbf{u}/\bar{\mathbf{u}}$ ,  $\mathbf{d}/\bar{\mathbf{d}}$ ) worked together with the previously formed 2 pairs of neutrinos ( $\nu_{\mu}/\bar{\nu}_{\mu}$ ,  $\nu_e/\bar{\nu}_e$ ) to make "strong interaction" emerge, and by doing so composed the  $\pi$ -on group ( $\pi^+$ ,  $\pi^-$ ,  $\pi^{\pm}$ ,  $\pi^0$ ) and the nucleon group ( $\mathbf{p}$ ,  $\bar{\mathbf{p}}$ ,  $\mathbf{n}$ ,  $\bar{\mathbf{n}}$ ). Furthermore, it will later be made clear how not just 120 types of atomic nuclei but all the particles/antiparticles that exist in the universe were composed mainly through the acting of "weak interaction" only with the  $\pi$ -on group and the nucleon group as the materials.

## **1. Splitting "positive time," "negative time," "positive space," and "negative space" into "dynamic" and "static" entities**

The universe created "positive time," "negative time," "positive space," and "negative space" by way of the causality between the 4 infinite

entities (time, space, energy, and heat) that existed in one point. Furthermore, the "emergence force of the universe," which is the first force, used half of the entirety of the 4 entities starting with "positive time" to compose and form "pre-space-time" and "neutrinos." This research paper will examine the development that used the remaining half of these entities to compose "quarks" and "space-time" (Fig. 1). The conversion of the 4 entities starting with "positive time" that were the entirety of the universe into "pre-space-time," "neutrinos," "space-time," and "quarks" (which are the sources of all phenomena in the universe, bar none) made it impossible for new entities to emerge.

As the third work exhibited by the "emergence force of the universe," the remaining half of the 4 entities starting with "positive time" were separated into "dynamic" and "static" entities respectively. In other words, the "heat" contained within "positive space" and "negative space" possessed the motive force to expand the universe to its final infinite size. As the process of moving toward the final state, "positive space" was separated into "static space" and "dynamic space" and "negative space" was separated into "anti-space" and "anti-dynamic space." Receiving this change, the "energy" contained within "positive time" and "negative time" likewise possessed the motive force to move the universe forward to its final infinite size. As the process of moving toward the final state, "positive time" was separated into "static time" and "dynamic time" and "negative time" was separated into "anti-time" and

"anti-dynamic time" (Fig. 2). Reaching this stage, the 4 entities starting with "positive time," which became the materials of the entirety of the universe, fully disappeared from the universe in their form as independent existences.

Strictly speaking, the "heat" and "energy" contained within the 4 entities starting with "positive time" must be separated equally into both the "dynamic" and "static" entities. However, it is impossible for the 4 entities of "dynamic time," "dynamic space," "anti-dynamic time," and "anti-dynamic space" (which composed space-time/anti-space-time) to become motive forces of some sort of physical forces to emerge after this point, so "heat" and "energy" were not necessary for these entities. Hence, it was inevitable that the "energy" and "heat" contained within the 4 "dynamic" entities would transition to the 4 "static" entities that compose quarks/anti-quarks. The "static entities" already contained a set amount of "energy" and "heat," so the transitioned "energy" and "heat" became a different motive force: "electrical charge" (Fig. 2). The "energy" that entered into "static time" became a positive electrical charge due to the fact that this is an entity that moves forward. Corresponding to "static time," "static space" took on a negative electrical charge due to the fact that it is an entity that expands. "Anti-time" and "anti-space" correspond, respectively, to "static time" and "static space," so they took on, respectively, negative and positive electrical charges. Calculating in reverse from the 2 pairs

of quarks ( $u/\bar{u}$ ,  $d/\bar{d}$ ), the 4 "static" entities took on the following electrical charges: +1/3 for "static time," -1/3 for "anti-time," -1/3 for "static space," and +1/3 for "anti-space" (Fig. 2).

## **2. Determining the types and structures of quarks and anti-quarks**

This research paper has shown how quarks/anti-quarks—which were believed to be single components that cannot be disassembled—are combinations of materials consisting of 4 types of entities ("static time," "anti-time," "static space," and "anti-space"). When quarks/anti-quarks formed, the causality between the 4 entities starting with "static time" became the "formation force of quarks," which is the second force. "Step 1 of the formation force of quarks" formed the 2 pairs of quarks/anti-quarks ( $u$ ,  $\bar{u}$ ,  $d$ ,  $\bar{d}$ ) by using the "energy" and "heat" within the entities of "static time," "anti-time," "static space," and "anti-space" as motive forces. Eventually, quarks/anti-quarks will become the main body of atomic nuclei and anti-atomic nuclei, so it is not possible to mix together positive and negative "time" and "space" in the same manner as neutrinos. Therefore, quarks are constructed by combining "static time" and "static space" and anti-quarks are constructed by combining "anti-time" and "anti-space." Assuming the formation of atomic nuclei in the distant future from this point, the types of quarks with positive shapes are the

u-quark with an electrical charge of  $+2/3$  and the d-quark with an electrical charge of  $-1/3$ . The universe does nothing wasteful, so the combinations of the materials of "static time" and "static space" with the smallest amounts were selected in constructing the u-quark with an electrical charge of  $+2/3$  and the d-quark with an electrical charge of  $-1/3$ . The u-quark with an electrical charge of  $+2/3$  is constructed from 3 components of "static time" and 1 component of "static space." The d-quark with an electrical charge of  $-1/3$  is constructed from 3 components of "static space" and 2 components of "static time" (Fig. 3 - center). Anti-quarks are constructed such that the materials of "anti-time" and "anti-space" combine in the smallest amounts with "static time" and "static space" described above replaced with "anti-time" and "anti-space." Therefore, the anti-u-quark with an electrical charge of  $-2/3$  is constructed from 3 components of "anti-time" and 1 component of "anti-space." The anti-d-quark with an electrical charge of  $+1/3$  is constructed from 3 components of "anti-space" and 2 components of "anti-time" (Fig. 3 - center).

The 2 pairs of quarks/anti-quarks formed above ( $u, \bar{u}, d, \bar{d}$ ) will later use "strong interaction" and work together with 2 pairs of neutrinos ( $\nu_\mu/\bar{\nu}_\mu, \nu_e/\bar{\nu}_e$ ) to compose the  $\pi$ -on group ( $\pi^+, \pi^-, \pi^\pm, \pi^0$ ) and nucleons/antinucleons ( $p, \bar{p}, n, \bar{n}$ ) having electrical charge composition of  $(+1, -1, 0, 0)$ . In addition, let us state in advance that it is possible to finally compose 120 types of atomic nuclei from



quarks/anti-quarks through the acting of "strong interaction" and "weak interaction" (Fig. 3).

### **3. Component ratio of "time" to "space" in quarks**

The totals of "time" and "space" components in quarks (**u**, **d**) are **u** (3 static time components + 1 static space component) + **d** (3 static space components + 2 static time components) = 5 "static time" components + 4 "static space components," which gives a ratio of 5:4 for the "time" and "space" that participated in the composition of quarks. The ratio of "time" and "space" in the composition of anti-quarks is also 5:4 (Fig. 4). For the constituent materials of quarks/anti-quarks, the universe used an accurate quarter of all the "positive time," "negative time," "positive space," and "negative space," so the ratio of the amounts of "time" and "space" entities should be 1:1. Regardless, while 5/5 of the amount of "time" was used in the composition of quarks/anti-quarks, only 4/5 of the amount of "space" was used in the composition of quarks/anti-quarks.

The reason why the "emergence force of the universe," which is the first force, separated the 4 entities starting with "positive time" into "dynamic" and "static" entities was to use the "dynamic" entities as the constituent materials of space-time/anti-space-time. However, at the stage in which quarks/anti-quarks formed in the universe, there was as of yet no need for space-time/anti-space-time to form.

Space-time/anti-space-time began to form after elements and compounds started to form. The constituent materials of the entire universe had to form at this point in time, even if there was as of yet no need for them. Even if gluons, weak bosons, and the Higgs boson are necessary, it is 100% impossible for the materials that compose these particles to be provided at a later time. If we assume that the constituent materials of space-time/anti-space-time are stored somewhere with a volume of 0 until they are needed, these would each be stored in corresponding "static" entities. The constituent entities of space-time are the "dynamic time" with the same amount of "static time" that separated from "positive time" and the "dynamic space" with the same amount of "static space" that separated from "positive space." Therefore, in the same manner of the composition of quarks/anti-quarks, while 5/5 of the amount of "time" was used in the composition of space-time, only 4/5 of the amount of "space" was used in the composition of space-time. The ratio of the amounts of entities of "time" and "space" used in the composition of anti-space-time is exactly the same as the component ratios for quarks/anti-quarks and space-time (Fig. 4).

Hence, even if the "dynamic" and "static" entities are used in the composition of space-time/anti-space-time and quarks/anti-quarks, there is an excess of 1 positive and 1 negative "space" component for both the "dynamic" and "static" entities. Particles/antiparticles are

connected by causality such as "strong interaction" and "weak interaction," however, space-time and anti-space-time will not be connected causally in the future. Therefore, it can only be believed that 1 component each of "dynamic space," "static space," "anti-dynamic space," and "anti-space" that are neither physical matter nor space have become the materials of a structure that fills the role of connecting space-time and anti-space-time in a causal manner. That is, there is nothing but the formation of black holes (Fig. 4 - bottom). There is no mistake in saying that black holes are a phenomenon, but they are formed not through the cooperation of "time" and "space" but only by way of "space," which is an exception. Space-time endlessly expands in the positive direction and anti-space-time endlessly expands in the negative direction. Yet, "black holes" do not expand. Therefore, time does not flow in "black holes."

#### **4. The main body of the flow of time**

Because the universe developed as a result of the acting of causality, it must be believed that the flow of time is the acting of causality. In other words, if causality does not act, time cannot flow. Therefore, strictly speaking, the "main body of time" is the "time" and "space" that have created the universe and made it develop. However, because the motive forces that cause "time" and "space" to move are "energy" and "heat," the "main body of time" is the causal relationships between

"time," "space," "energy," and "heat"; in other words, the development of the causality of the entire universe. In detail, the chronology of time from the emergence of the universe to the formation of neutrinos is as follows. The 4 entities starting with "positive time" emerged due to the "fundamental development force of the universe" [3], pre-space-time and neutrinos were formed due to the acting of steps 1 and 2 of the "emergence force of the universe" [3], and then quarks/anti-quarks as well as space-time/anti-space-time were formed due to "steps 1 and 2 of the formation force of quarks." In other words, time transitioned just this amount due to the acting of the "fundamental development force of the universe," "steps 1 and 2 of the emergence force of the universe," and "steps 1 and 2 of the formation force of quarks" (Fig. 5 - right).

Hence, the tempo of the development of the universe (which is the transition of time at the beginning of the universe) is the tempo of the acting of the "fundamental development force of the universe," the "emergence force of the universe," and the "formation force of quarks." The tempo of the acting of the "emergence force of the universe" and the "formation force of quarks" is on a completely different level from the speed of the acting of "gravity" moving the universe, which is the tempo of current time. The Standard Model believes that fundamental particles such as neutrinos and quarks emerged due to "vacuum phase transitions." However, "vacuum phase transitions" are not causal phenomena so time would not have moved even 1 second. What's more,

the universe develops together with the passage of time. Therefore, it is not possible for fundamental particles such as neutrinos and quarks to have emerged due to "vacuum phase transitions."

## **Discussion**

Current physics believes that the universe emerged and developed according to a coincidental sequence. It also believes that quarks/anti-quarks emerged in a non-causal manner together with neutrinos and gauge bosons, that is, by way of "vacuum phase transitions." Furthermore, it also believes that there exist quarks (s, c, b, and t) that have amounts close to zero when compared to the **u**- and **d**-quarks. Without assuming that all the materials and causality that compose the entire universe existed already when the universe was a single point, there should have been no way for the universe of today to be created. In the same manner, without first drawing the design diagrams of the structures of 2 pairs of 4 types of up and down quarks/anti-quarks (**u**,  $\bar{\mathbf{u}}$ , **d**,  $\bar{\mathbf{d}}$ ) at the time when these quarks/anti-quarks were formed, it should have been absolutely impossible to form nucleons/antinucleons and to thereafter construct an extremely precise 8-layer structure of 120 types of atomic nuclei. Regardless, the Standard Model has not taken the steps to explain quark/anti-quark charges and the problems of their consistency or the

acting of "strong interaction" and "weak interaction" and the problems of their consistency.

This research paper has successfully made clear the formation of quarks/anti-quarks in a causal manner and also in a form that corresponds to space-time/anti-space-time. The result is that the following points have been made clear: quarks/anti-quarks are not single components; among all the compositional elements of the universe, quarks/anti-quarks are the only entities that are given electrical charges; and the only quarks/anti-quarks that formed were the 2 pairs of 4 types of up and down quarks/anti-quarks ( $\mathbf{u}$ ,  $\bar{\mathbf{u}}$ ,  $\mathbf{d}$ ,  $\bar{\mathbf{d}}$ ). At the same time, this research paper has made clear the structure of the 4 types of quarks/anti-quarks. In addition, this research paper has inevitably identified the constituent materials of "black holes," which are not space-time/anti-space-time or (obviously) physical matter from the quantitative correspondence relationships between the materials of space-time/anti-space-time and quarks/anti-quarks. Furthermore, this research paper has concluded that "time" is the development of the universe itself, which is caused by the causality between the 4 entities.

From the conclusion of this research paper that the precursor particles that become the materials of all particles/antiparticles are only 2 pairs of neutrinos ( $\nu_{\mu}/\bar{\nu}_{\mu}$ ,  $\nu_e/\bar{\nu}_e$ ) and quarks/anti-quarks ( $\mathbf{u}/\bar{\mathbf{u}}$ ,  $\mathbf{d}/\bar{\mathbf{d}}$ ), that is, that no new precursor particles emerge in the universe at later stages, "strong interaction" and "weak interaction" are made to act

just by the 2 pairs of 4 types of neutrinos and quarks/anti-quarks listed above and, without exception, all particles/antiparticles, electromagnetic waves, atomic nuclei/anti-atomic nuclei, etc. that currently exist in the universe must be constructed from these neutrinos and quarks/anti-quarks. Therefore, the formation of quarks/anti-quarks ( $u, \bar{u}, d, \bar{d}$ ) is extremely significant. Unfortunately, it is not possible to confirm this significance within this research paper. We plan to verify the correctness of the entirety of the above conclusions through various research papers in the future.

## Acknowledgments

We would like to take this opportunity to express our deep appreciation for the expert assistance of Mr. Kōichirō Tanibe in creating the final illustrations, performing the text layout, and in doing various other tasks.

## References

- [1] R.M. *The charm of strange quarks*. 147-171 Springer-Verlag Tokyo (2005).
- [2] B. Povh, K. Rith, C. Scholz, F. Zetsche. *Teilchen und Kerne*. 89—99. Springer-Verlag Tokyo (1997) .

[3] Ozawa,N,**M-1**: The Universe That Emerged and Developed in a Causal Manner[submitted to ].

### **Figure legends**

#### **Fig. 1 Positioning of the quarks/anti-quarks in the entire universe**

Half of the 4 entities starting with "positive time" remaining from the formation of pre-space-time/anti-pre-space-time and neutrinos were separated into halves and formed space-time/anti-space-time and quarks/anti-quarks.

#### **Fig. 2 Separating the 4 entities starting with "positive time" into 4 types of "dynamic" and "static" entities**

The 4 entities starting with "positive time" were separated into 4 types of "dynamic" and "static" entities. The "energy" and "heat" contained within the 4 "dynamic" entities transitioned to the 4 "static" entities and became their electrical charges.

#### **Fig. 3 Further development of quarks/anti-quarks**

Without any problems, it was possible for the quarks/anti-quarks ( $u/\bar{u}$ ,  $d/\bar{d}$ ) that formed to—through "strong interaction" mediated by 2 pairs of neutrinos ( $\nu_\mu/\bar{\nu}_\mu$ ,  $\nu_e/\bar{\nu}_e$ )—construct the  $\pi$ -on group ( $\pi^+$ ,  $\pi^-$ ,  $\pi^\pm$ ,  $\pi^0$ ) and nucleons/antinucleons ( $p$ ,  $\bar{p}$ ,  $n$ ,  $\bar{n}$ ) having electrical charge composition of (+1, -1, 0, 0). In addition, there was not even the slightest contradiction in the later creation of 120 types of atomic



nuclei/anti-atomic nuclei with the formed quarks/anti-quarks ( $u/\bar{u}$ ,  $d/\bar{d}$ ) as their materials and through the acting of "strong interaction" and "weak interaction."

**Fig. 4 Component ratios of "time" to "space" for quarks/anti-quarks and space-time/anti-space-time**

The component ratios of "time" to "space" for both quarks/anti-quarks and space-time/anti-space-time are 5:4. Positive and negative "black holes" formed from the remaining 2 pairs of positive and negative "space" entities.

**Fig. 5 Chronology of time**

Due to the fact that the "main body of time" is the development of the causality of the entire universe, time passed and pre-space-time/anti-pre-space-time, neutrinos, space-time/anti-space-time, and quarks/anti-quarks were formed due to the acting of causality such as the "emergence force of the universe" and the "formation force of quarks." On the other hand, the "vacuum phase transitions" of the Standard Model are not causal phenomena, so it is not possible for "time," which forms neutrinos and quarks/anti-quarks, to flow.

Fig. 1

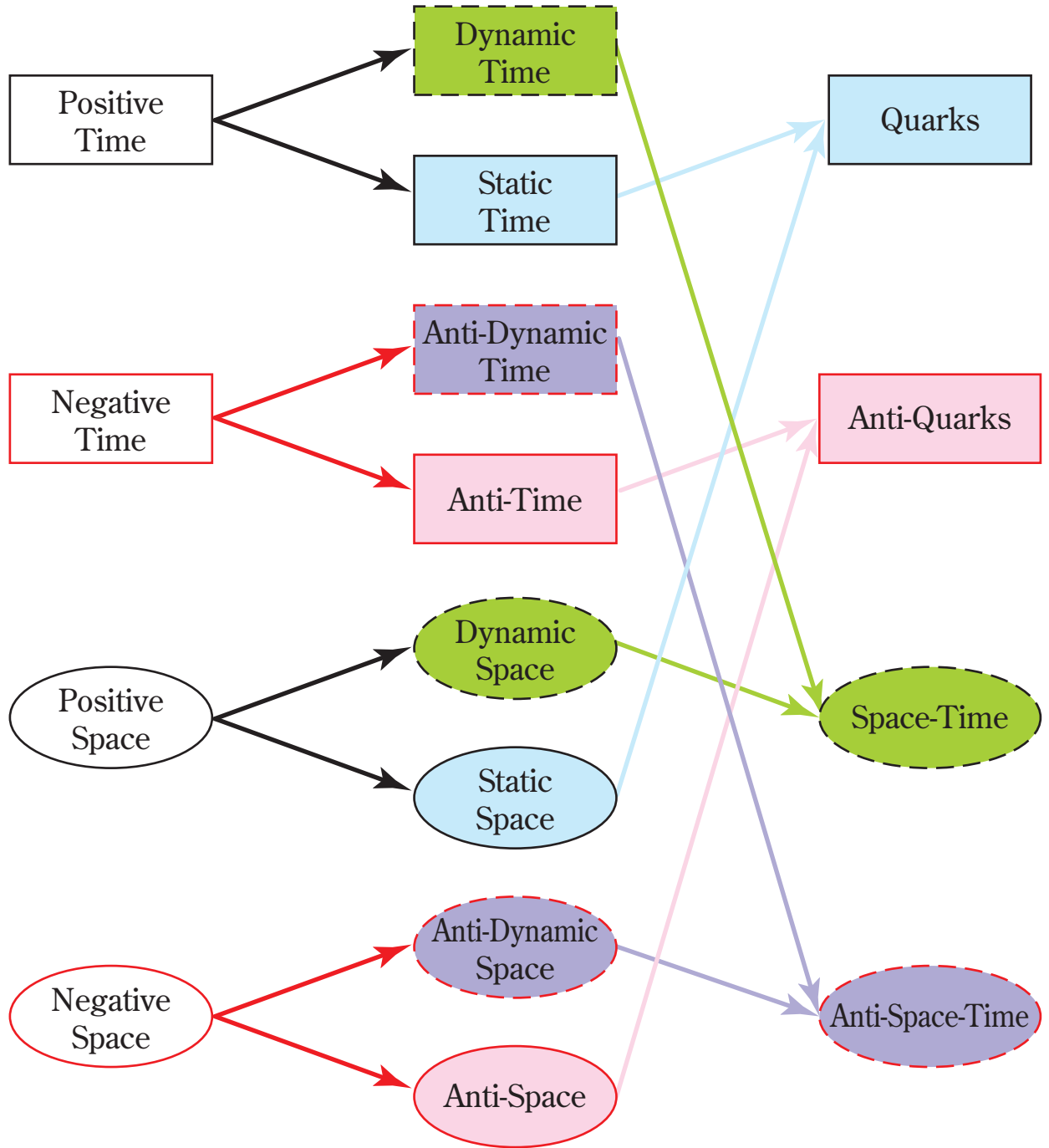

# Fig. 2

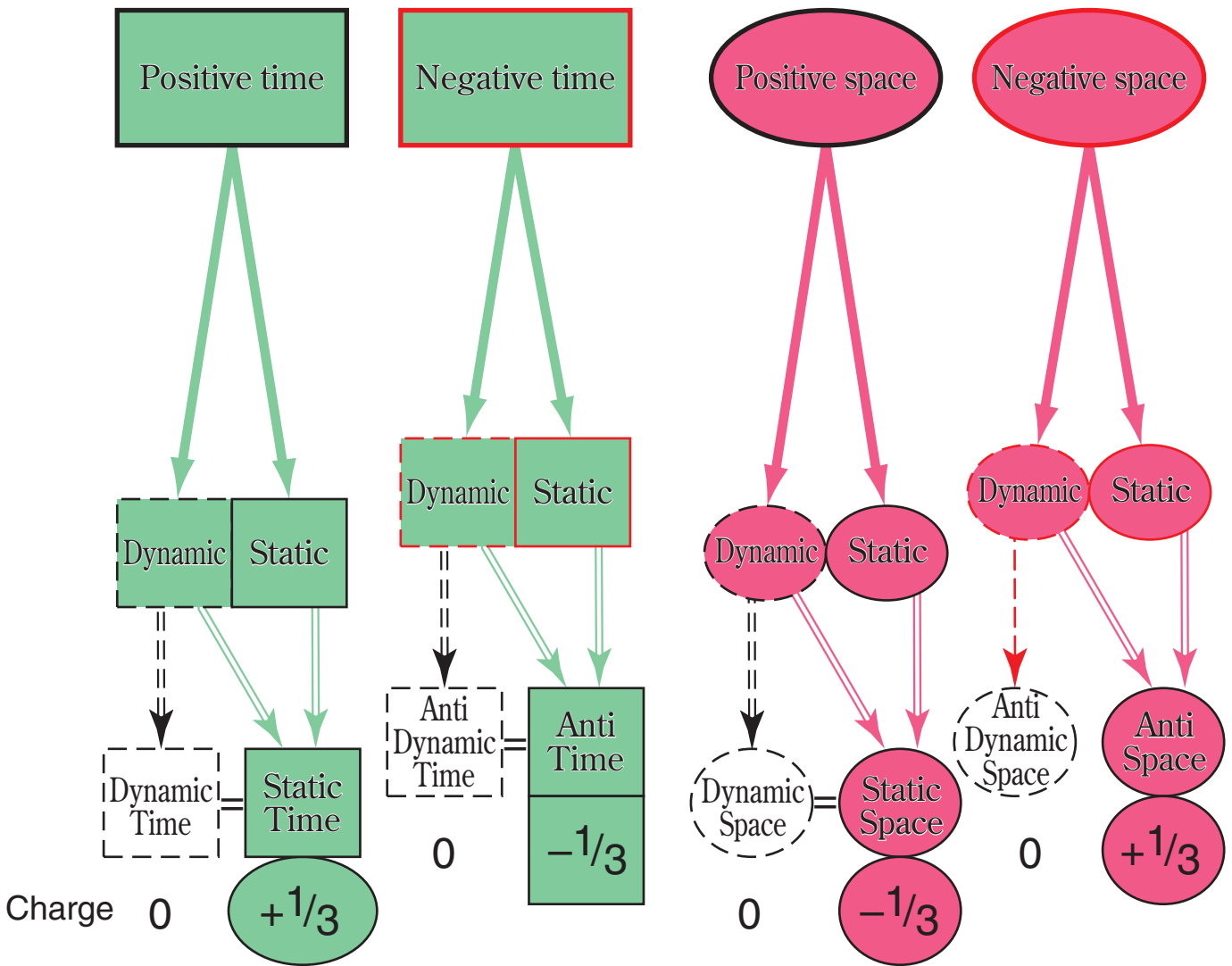

# Fig. 3

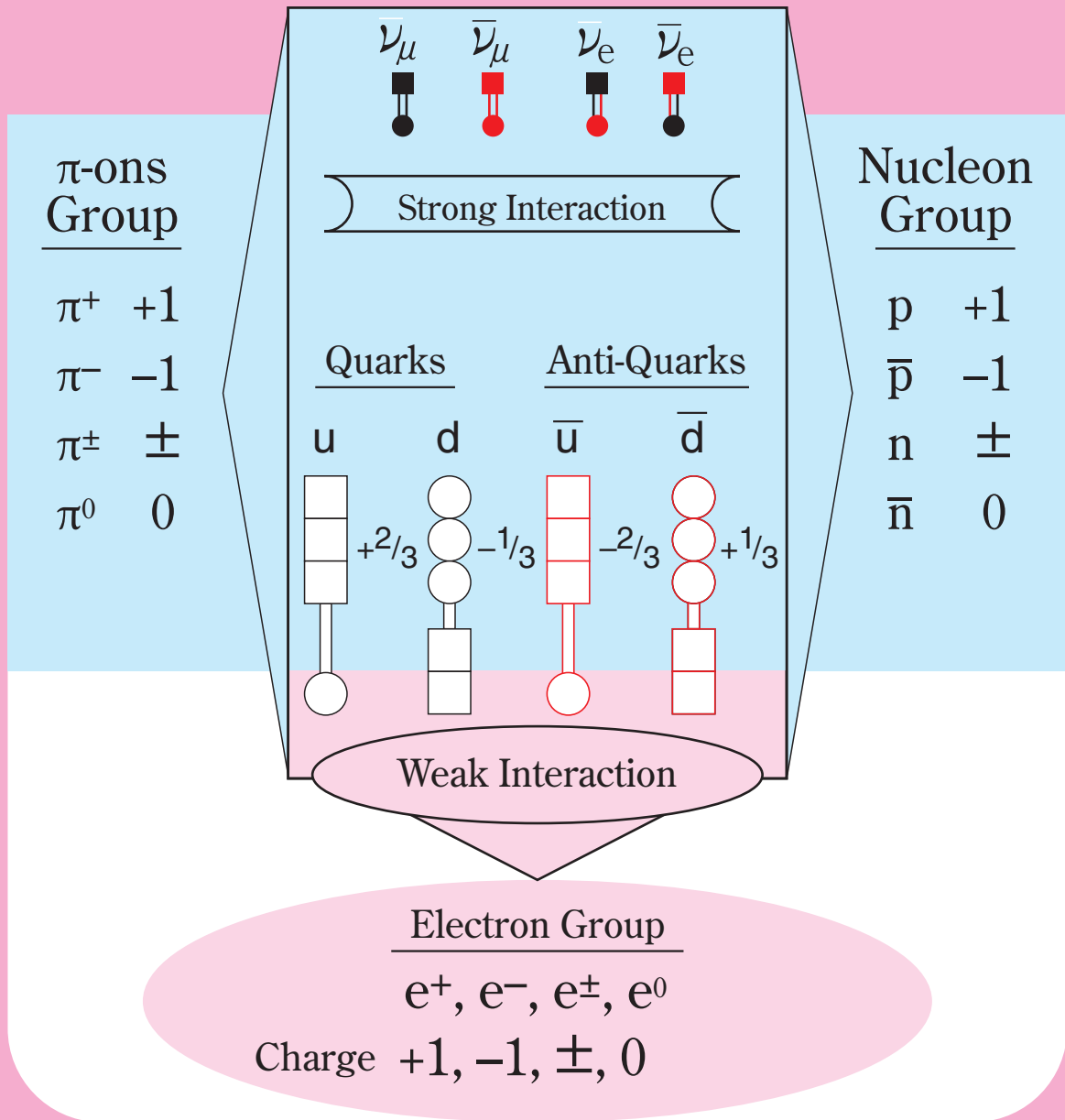

## 120 Kinds of Elements

# Fig. 4

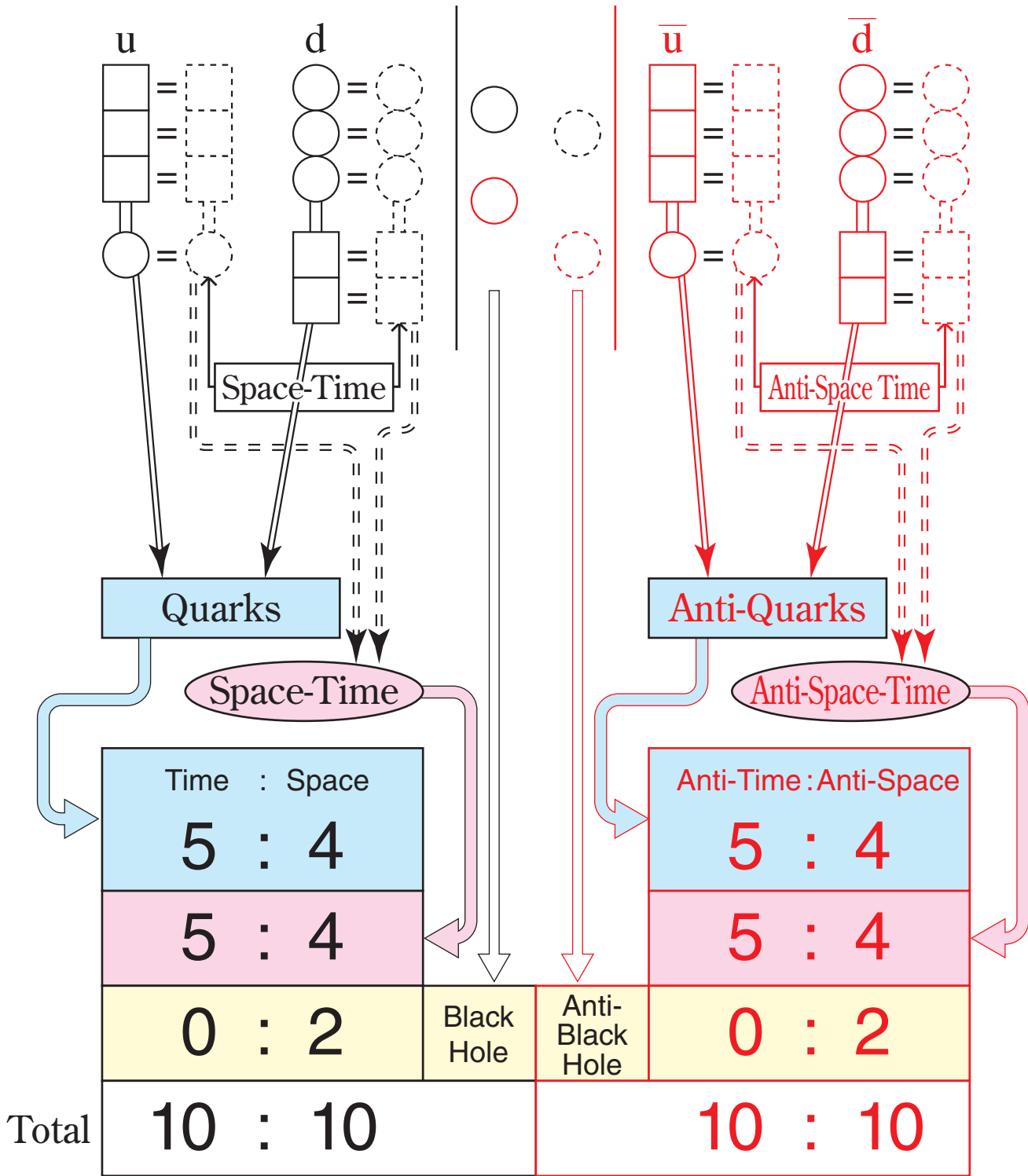

# Fig. 5

