

TITLE :

Mathematical Proof of a feasible warp drive and time travel mechanism

AUTHOR :

Name : DR. Gautam Narayan Baruah

Address : C/O J.N.Baruah

Jorhat - 785001

Assam, India

Phone : 91 9678946027

E-mail : gautamnarayanbaruah@gmail.com

Abstract :

When a body say a toy car slides down an inclined plane with angle of inclination less than 45 degree the downward and forward motion of the toy car can be restricted by a thread or support perfectly parallel to the horizontal. It can be mathematically proved based on the law of conservation of energy that a portion of the weight of the toy car is unsupported even at the position of rest and sinks down in the same relative space causing compression of spacetime below the toy car . This is a mathematical proof of a plane solid surface where an object can rest with part of it's weight not supported even at the position of rest enabling a novel warp drive and time travel mechanism that can work without causing any physical harm to human subjects.

Key Words :

Working warp drive; Feasible time trave for human subjects;time reversal;artificial gravity;artificial hyperspace.

1)Introduction:

If a man of 50 kg tries to lift the weight measuring machine on which he is standing vertically upwards with a rope he would still weigh 50 kg.

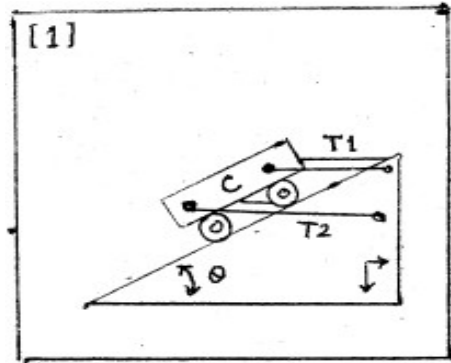

Similarly in accordance with the law of conservation of energy when a toy car C as in figure 1 of weight 'mg' slides down an inclined plane it's weight can be divided into components-

- (a) $(mg\cos\theta + MKmg\cos\theta)$ perpendicular to the plane surface
- (b) $(mg\sin\theta - MKmg\cos\theta)$ parallel to the plane surface

Where θ is the angle of inclination of the plane and 'MK' is the coefficient of friction. For an inclination of the plane of less than 45° the forward and downward motion of the toy car can be restricted by strings T_1 and T_2 perfectly parallel to the horizontal. This enables a solid plane horizontal surface where an object can rest with part of it's weight not supported even at the position of rest.

2)Theory and calculation:

If Mk is the coefficient of friction then weight of the body not supported by friction is

$$=\{mg - (Mk \times mg)\}$$

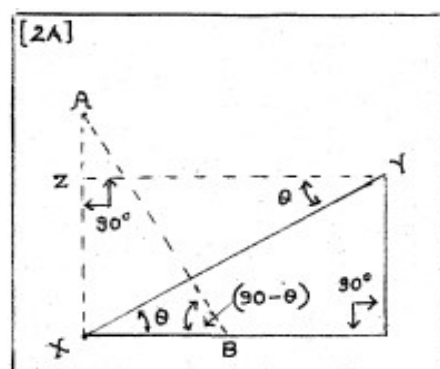

Figure 2A - Let plane XY be inclined to the horizontal at θ . Then line AB perpendicular to plane XY is inclined to the horizontal at $(90 - \theta)^\circ$

From figure 1 and 2A

$$AB = mg \cos \theta$$

$$AX = mg \cos \theta \times \sin(90 - \theta)$$

So the weight of the toy car unsupported even at the position of rest,

$$mg_{\text{unsupported}} = mg - [(MK \times mg) + mg \cos \theta \times \sin(90 - \theta)]$$

If the weight of the toy car is 1kg and inclination of the plane 30° to the horizontal then -

$$mg_{\text{unsupported}} = mg - [(MK \times mg) + 0.749956]$$

So $mg_{\text{unsupported}}$ is positive if coefficient of friction MK is less than 0.25.

From figure 1 and 2A perfectly horizontal component ZY is supported and vertical component ZX is unsupported, so $mg_{\text{unsupported}}$ is maximum if the inclination of the plane is 45° to the horizontal.

Due to the weight unsupported the toy car must sink towards the solid surface in the same relative space. This must tend to increase the amount of energy per unit space like a compressed spring pressing on a surface without any actual addition of energy. Due to the law of conservation of energy the actual weight falling vertically on the inclined plane surface is always equal to $mg_{\text{unsupported}}$. But due to the pressing action like a spring the reaction from the support must take place a little earlier so that the apparent length of the toy car remains unaltered. This means over the same period of time the inclined plane supported a portion of the weight of the toy car over an increased distance 'D'.

So work done or energy transfer is -

$$W = \text{Weight unsupported} \times D$$

From - Figure 1 and 2A,

$AB = (\text{Weight unsupported} \times D) \cos \theta$ as the toy car still seems to be sliding down the inclined plane.

So, at the position of balance and rest for the toy car --->

We get,

$$\sin(90 - \theta) = \{ (\text{weight unsupported}) \div (\text{weight unsupported} \times D) \cos \theta \}$$

So that,

$$\text{weight unsupported} \times D = \{ [\text{weight unsupported}] \div [\sin(90 - \theta) \times \cos(\theta)] \}$$

So that,

$$D = \{ 1 \div [\sin(90 - \theta) \times \cos \theta] \}$$

Here we express mass as energy already present in the rest frame of reference,

From the equation for mass-energy equivalence ,

Apparent rest mass-

$$m_o = \{ [1 \times m_g \text{ unsupported}] \div [\sin(90 - \theta) \times \cos \theta \times C \times C] \}$$

If each point in proper space is a particular point in time then for motion in the same relative space-

There is more amount of spacetime and so apparent mass-

$$m_o = \{ (\text{ spacetime} \times m_g \text{ unsupported}) \div (C \times C) \}$$

This interrelates energy, mass and spacetime. Motion in the same relative space in two mutually perpendicular directions then enables energy to collapse to a point that explains curvature of spacetime and gravity in the presence of energy or mass.

Since speed of light 'C' is the cosmic speed limit for human sense-

If momentum 'MN'=(spacetime or energy ÷ C), then-

Momentum MN with unit of Kg metre per second generated in the above condition, $MN = \frac{1 \times mg}{\sin(90 - \theta) \times \cos \theta \times C}$

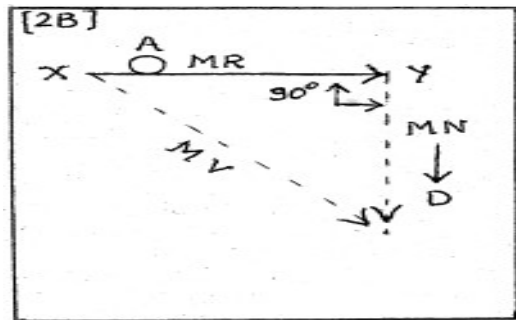

In figure 2B object A is in motion on solid horizontal plane XY where a part of it's weight is not supported even at the position of rest. Let MV be the actual momentum of the object and M it's relative mass. We can now calculate the negative momentum of the particle from the relationship above. Also no work is done if we move an object perpendicular to the direction of the applied force. Then resultant momentum MR in solid plane XY is reversed -

$$(MR \times MR) + (MN \times MN) = MV \times MV$$

$$\text{So that , } MR = \sqrt{(MV \times MV) - (MN \times MN)}$$

The condition is same for a body hanging down from plane XY and stretching.

It is known that any material body needs progressively more force to speed up. It might be that as energy is proportional to frequency, the same force tends to act briefly proportionately per unit space relative to a rest observer. With the motion of energy in the same relative space the same force tends to act early in the time dimension enabling warp drive and faster than light travel. Due to the law of conservation of momentum as the unidirectional force exceeds the rest mass of an object spontaneous inertial motion needs to result. Since the laws of physics are same in all the inertial frame of reference there will always be a reference frame with respect to plane XY as in figure 2B at relative rest. So the prospect of time travel is real. Since no time or energy is required as motion occurs in the same relative space so the grandfather paradox cannot occur.

$$\text{So, } \{(1 \times \text{mgsupported}) \div (\sin(90-\theta) \times \cos \theta \times C) \times N\} - \text{Rest mass} = \text{Rest mass} \times V$$

Where 'N' is the number of units as in the material and method section and 'V' is the final velocity of the warp drive which has no speed limit.

3) Material and method with some results:

3.1 If we allow water to trickle down an inclined plane or rising hot candle fumes to strike an inclined roof top or sail we shall not be able to detect the minute unidirectional force or momentum. But if we arrange the phenomenon at the end of a lever rod long enough to magnify the unidirectional force capable of rotation about an axis at the other end and hold the axis in a tube like support with the length of the lever rod perfectly perpendicular to the direction of gravity the bar exhibits unidirectional motion not explained by ideomotor effect and the direction of motion can be predetermined by control study. Materials for the experiment may include 1. A rectangular piece of cork as lever rod 2. A long needle used to knit sweaters as axis for the lever rod 3. Pins or needles to fix things easily on the cork surface 4. Cotton threads to form knots and connections to mimic an inclined plane surface 5. Lower part of a ball point pen as hollow tube like support for long needle or axis to rotate.

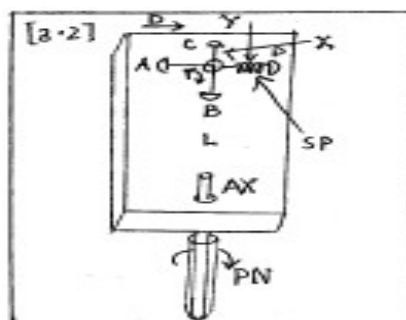

3.2 Figure 3.2 shows thread X connected to pin C on cork slab L and thread Y connected to distended spring SP which is connected to pin D. X and Y form a Knot where they join. Thread T_H acts like an inclined plane where Knot K tends to slide forwards and down wards with forward movement restricted by thread X. The energy of the restoring force of spring SP undergoes time warp to support itself and the lever rod shows unidirectional motion in direction D.

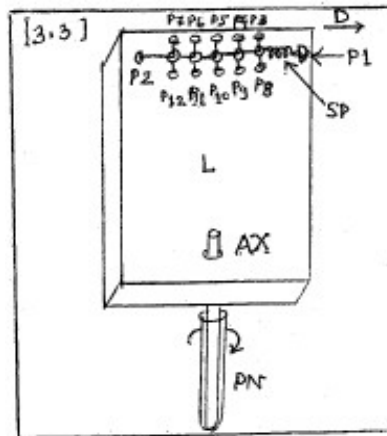

In figure 3.3 the time warp effect on the restoring force of spring SP is increased by increasing the number of thread and Knot units arranged end to end in a perfectly straight line between pins P_1 and P_2 perpendicular to the length of lever rod L. An unidirectional motion in direction D is detected when the length of lever rod L made of cork is held perfectly perpendicular to the direction of gravity by axis of rotation AX capable of rotation on tube PN. However if the line joining P_1 and P_2 is not perfectly perpendicular to the length of lever rod L the direction of motion of the rod is reversed due to the time warp effect.

4) Discussion and conclusion :

From mathematical calculation based on the law of conservation of energy and the concept of unified spacetime we conclude that we need more than C or 3×10^8 number of knot and thread units as described in the material and method section to construct a working warp drive and feasible time travel device for use by human subjects. This is infact science to analyse the positive results of the material and method section without prejudice from repeated experiments which needs to be repeated in advanced laboratories to a high degree of accuracy.

References :

1. Mach E (1872) History and Root of the principles of the conservation of energy Open Court Pub. Co. Illinois.
2. Vander Waerden, Bortel Lunder (1983) - Geometry and Algebra in Ancient civilization Springer ISBN3- 540- 12159- 5
3. Einstein, Albert (1905-06- 30) "On the electrodynamics of moving bodies" Annalen der Physik 17(10) : 891- 921 .doi:10.1002/andp.19053221004
4. Einstein, Albert (1905) " Does the inertia of a body depend upon it's energy content"- Annalen der Physik 18(13) : 639- 641 doi:10.1002/andp.19053231314
5. Alcubieri, Miguel (1994) "The warp drive : hyperfast travel within general relativity"- Classical and Quantum Gravity 11(5) : L73 - L77.doi:10.1088/0264- 9381/11/5/001
6. Morris, Michael; Thorne, Kip ; Yurt sever, Ulvi (September 1988) " Wormholes, Time machines and the weak Energy condition" physical Review 61(13) : 1446 - 1449
7. Visser M(1995) Lorentzian Wormhoes - From Einstein to Hawking Woodbory NY : AIP press
8. Forward R.L. (1990) "Negative matter propulsion" J ournal of propulsion and power 6:28. doi:10.2514/3.23219
9. Hawking, stephen (April 27, 2010) "Stephen Hawking : How to build a time machine" Daily mail
10. www.andersoninstitute.com- Time Travel
11. Indian patent application 255/KOL/2015
"A time warp and free energy machine" Inventor - Baruah Gautam Narayan