

# How to Measure the One-Way Speed of Light

Vadim N. Matveev<sup>1</sup>, Oleg V. Matvejev

*The paper discusses a method of measuring the one-way speed of light based on the use of a rigid rod freely rotating around its axis. The authors analyze the conditions related to phase correlation and synchronism of rotation of the rod ends in the reference frame wherein its axial velocity is zero and in the reference frames wherein it moves at a high axial velocity. The anticipated results of the experiment within special relativity and Lorentz ether theory are also considered.*

## I. The Background and the Main Points

The theory of special relativity (TSR) comprises the problem of synchronization of clocks, meaning that in order to synchronize clocks the postulate of the equality of the speed of light in opposite directions (two-way speed of light) is used while an experimental validation of this equality is deemed impossible in principle [1-4]. To measure the speed of light from point  $A$  to point  $B$ , and then back from point  $B$  to point  $A$ , then to compare these speeds, it is necessary to have synchronized clocks in points  $A$  and  $B$ . However, as is often the case, one cannot synchronize the clocks in points  $A$  and  $B$  otherwise than on the assumption made before taking measurements of these speeds that they (the speeds) are equal. It is natural that on implementation of such an assumption they become equal by the results of the measurement as well.

It is impossible to measure speed unambiguously. Having synchronized a pair of clocks in point  $A$  and then having transferred one of them to point  $B$ , as the result of synchronization and measurement of the speeds of light  $v_{AB}$  and  $v_{BA}$  respectively from point  $A$  to point  $B$  and vice versa becomes dependant on the speed at which the clocks are transported from one point to

---

<sup>1</sup> matwad@mail.ru

another. For example, after the transfer of the clocks from  $A$  to  $B$  at a speed close to that of light, the subsequently measured speed  $v_{AB}$  will become arbitrarily large, and the speed  $v_{BA}$  will be arbitrarily close to  $c/2$ . Under such synchronization, light almost instantly arrives from point  $A$  to point  $B$ , but goes back twice as slow as usual. At a very slow rate of transfer the speeds  $v_{AB}$  and  $v_{BA}$  will be equal.

So what speed of the transfer of the clocks is believed 'correct'? This question has no definite answer. Particularly, it is for this reason that in special relativity synchronization of the clocks at different points in space is performed by light signals, and not by their transfer from one point to another. Today many believe that the equality of speeds of light in different directions is an evident 'fact', whereas there are no grounds for an a priori preference of fast transportation of the clocks to slow one.

It should be noted that in practice the problem of the one-way speed of light is not considered topical as there exists a way of measurement of the speed of light by means of a single clock and a mirror. Applying this method, it is solely this clock that can measure a time interval between sending a light pulse to a mirror and receiving the pulse that has returned to the starting point, having reflected from a mirror. The speed is measured by a double distance between the clock and the mirror and by the time it takes light to travel there and back. Strictly speaking, the speed measured in this way is the average speed on the way there and back because the speed there may not be equal to the speed back.

Measuring the average speed does not cause any clock synchronization problem. No matter how we synchronized the second clock, the assumption-free average speed of light on the way there and back would be equal to the constant  $c$ . It is evident, because the result of the experiment does not depend either on the readings of the clock at point  $B$ , or on its very presence there.

It is often said that the one-way speed of light was measured by Roemer. Strange enough, but Roemer's speed is also a speed obtained on an implicit assumption of the equality of the two-way speeds of light. The matter is that Roemer and Cassini discussed the movement of Jupiter's satellites, having deliberately assumed that the observers' space is isotropic. Karlov, an Australian physicist [5], showed that Roemer actually measured the speed of light, having implicitly made an assumption of the equality of the two-way speeds of light.

The assumption of the equality of the speed of light from  $A$  to  $B$  and that from  $B$  to  $A$  was considered by Poincare, and it was this assumption that became the main postulate of Einstein's 1905 paper [6], though it was not presented in the postulate form, but as a 'definition' preceding two Einstein principles often called postulates. In a later work Einstein called this 'definition' an assumption, he wrote: 'But if the speed, in particular the speed of light, is essentially impossible to measure without arbitrary assumptions, then we may make arbitrary assumptions as to the speed of light as well. Now, let us assume that the light propagation speed in vacuum from point  $A$  to point  $B$  is equal to the speed of light from  $B$  to  $A$ '.

It is often said that the equality of two-way speeds the equality of the light transit times between points  $A'$  to  $B'$  within some reference system  $K'$  in forward and reverse directions is evident, since space is isotropic. However, this 'evidence' exists only within its own reference frame  $K'$ . It is also clear to observers located within the reference frame  $K$ , relative to which the reference frame  $K'$  with respective points  $A'$  to  $B'$  is moving, that the light transit from point  $A'$  to point  $B'$  in the direction of motion of the frame  $K'$  needs more time than from  $B'$  to  $A'$ , if points  $A'$  to  $B'$  within the frame  $K$  follow one another.

The one-way speed of light is the starting point of all discussions on the problem of clock synchronization in special relativity, with a large number of papers dedicated to it. Its origination and development are also closely associated with a theory in philosophy known as

conventionalism. One of the founders of conventionalism is A. Poincare. Conventionalists believe that the one-way speed of light is the result of an agreement (convention). The agreement is reached under the condition of Reichenbach [7], which has the form

$$t_B = t_{A,1} + \varepsilon \Delta t.$$

Here  $\varepsilon$  is some arbitrary factor, with  $0 < \varepsilon < 1$ , and  $\Delta t = t_{A,2} - t_{A,1}$  is the time interval between the time  $t_{A,1}$  of sending the light pulse from point A and the time  $t_{A,2}$  of its return (having reflected from the mirror at point B) to point A, while  $t_B$  is the time of reflection of the pulse from the mirror at point B.

According to the Reichenbach condition the speed of light on the path from A to B equals  $\frac{1}{2}c$ , and on the path from B to A equals the value of  $\frac{1}{2}c/(1 - \varepsilon)$ .

If the factor  $\varepsilon$  is near-zero, the light almost instantly reaches the mirror (with the speed arbitrarily large) and returns at a speed  $\frac{1}{2}c$ . If the factor  $\varepsilon$  is near unity, the ratio of the speeds will be reverse. Finally, a special case of Reichenbach clock synchronization is the condition  $\varepsilon = \frac{1}{2}$ , where clocks are Einstein synchronized, and the two-way speeds of light become equal to each other (and equal to  $c$ ).

Is it true that the one-way speed of light is the result of a convention?

The paper [8] treats an example that casts doubt on the thesis of the conventional nature of the one-way speed of light.

The paper gives the following example. In a closed laboratory a great many of identical clocks that were initially at rest in close proximity to each other are simultaneously ejected in different directions by identical throwing mechanisms. At points equidistant from the place of ejection the clocks meet with the same obstacles; their reciprocal action leads to complete braking of the clocks.

Moved to a new position, the clocks are used to determine the one-way speed of light. Using Einstein isotropic description of kinematic effects, which is if not unique, but at least consistent, you can predict the result of the considered experiment without making it in reality.

It is clear that in any case readings of the clocks after their braking have to meet the Einstein condition of synchronism, and the one-way speed of light measured by means of any pair of clocks involved in the experiment would be equal to the constant  $c$ .

It is apparent that one can make a formally consistent assumption on the anisotropy of space and desynchronization of the clocks omnidirectionally ejected. However, the assumption by itself will not change the obtained experimental result indicating that regardless of whether we believe that the clock readings are synchronous or asynchronous, the speed of light measured by these clocks is equal to the constant  $c$  and does not depend on direction. Nevertheless, in order to experimentally verify the supposition and determine the inequality of the two-way speeds of light, it is necessary to consider the imaginary kinematic asymmetry of the process of the moving of the clocks, making an appropriate adjustment. As an example, to meet this purpose we could adjust the hands of the presumably desynchronized clocks. However, the observed inequality of the speed of light in opposite directions after making adjustments would not validate the assumption made, but it would rather result from a physical action artificially introduced into the experiment, which is not consistent with the method of finding dependence of the speed of light on direction *ceteris paribus*.

The above discussion shows that experimental detection of the isotropy of space in a closed laboratory does not require arbitrary assumptions, whereas experimental 'detection' of the inequality of the speed of light in opposite directions requires not only arbitrary

assumptions, but also arbitrary physical actions to validate the correctness of these assumptions.

The paper makes a special point that it does not deal with the issue that the speed of light in opposite directions may not be different. It only shows that Einstein clock synchronization in a closed laboratory does not require arbitrary assumptions. Moreover, showing the uselessness of arbitrary agreements for Einstein clock synchronization in a closed laboratory, the author notes that in the world of 'open' laboratories and inertial reference frames, from which it is possible to observe the same processes, the inequality of the speeds of light in opposite directions in a reference system  $K'$  is not an assumption but a fact which can be detected when observing propagation of light in the reference frame  $K'$  from the reference system  $K$ , where the two-ways speeds of light are the same. The vulnerability of the author's reasoning is that acknowledging the objectivity of the fact of the inequality of the two-way light speeds he ascribes relativistic nature to it.

Is it true that there is fundamentally no physical way to determine Reichenbach factor  $\epsilon$  or, which is essentially the same, to measure the one-way speed of light?

Strange as it may sound, not only does this method exist, but being almost evident, it is even put forward and discussed at physics forums. It is this method that has been realized in Marinov's experiments, and it is dealt with in many of his followers' works [9-12]. Although the degree of certainty of such experiments up to now remains unclear, the principle used or proposed in research of this kind can hardly be described as less than perfect. Unfortunately, the experiment of Marinov and his followers has received undeservedly little attention up to now. The results of Marinov's experiment are rather ignored than subjected to criticism (especially constructive). The method of measuring the speed of light, used by Marinov, is based on the use of synchronously rotating slotted disks, through which a light beam passes. The scheme of such a device is shown in Fig. 1.

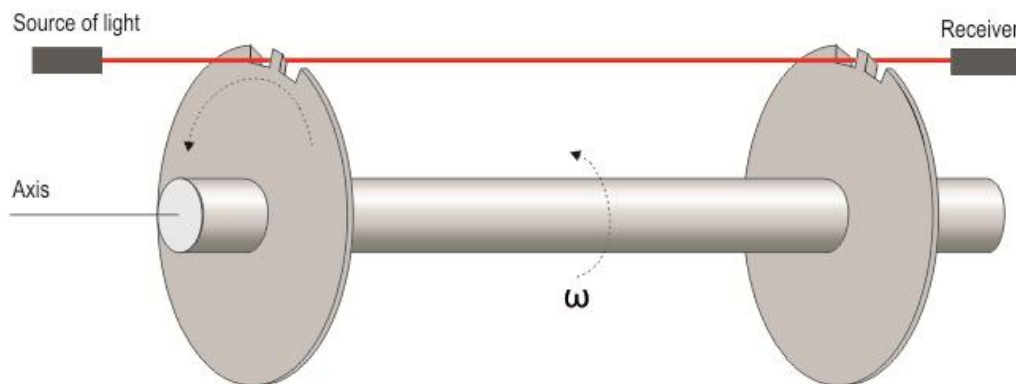

Fig. 1. One way speed of light measurement device with slotted disks, attached to rotating pin.

The device consists of two identical slotted disks fixed on the same axis, a light source and a photo detector. In a stationary position, a light beam freely passes through narrow slots in

the disks. In the working position, the disks rotate. The in-phase rotation is achieved not by conventions and arbitrary assumptions, but using a rigid rod that couples the disks. The rotation speed can be set arbitrarily. At a certain rotation speed during the light propagation from one disk to another, the edge of the second disk is displaced so that the slot moves away from the line of the beam propagation and no light enters the photo detector. One can calculate the speed of light from the source to the photo detector according to geometrical data of the device and the linear velocity of the edges of the disk whereby the beam that has passed through the slot of the first disk ceases to fall into the slot of the second disk. Having reversed the positions of the source and photo detector, it is possible to measure the speed of light in the opposite direction.

Let us note that it is the presence of a rigid rod coupling the disks that makes it possible to measure the speed of light. It may seem, for example, that you can spin two identical rigid disks, having coaxially arranged them next to each other and aligned the slots, to an identical angular velocity, then synchronously (on identical programmes) move sufficiently far apart in different directions and measure the speed of light. However, measuring the one-way speed of light by means of such 'in-phased' rotating disks will fail, even though we admit the possibility of solving technical issues associated with maintaining the consistency of rotation of the disks in the process of their separation. The analysis of the behaviour of such rotating disks shows that during separation their rotation synchronism is broken in such a way that the false value of the speed measured using these disks will be equal to the constant  $c$ . A rigid rod due to the forces of elasticity ensures preservation of synchronism in absolute space.

The only problem that arises when considering the measurement of the speed of light by the use of rod-coupled disks is the ambiguity of the effect of rotating rod torsion in different inertial reference frames on the expected results of the one-way speed of light measurement. The problem is that in special relativity the rod, which rotates freely, without being subjected to deformation in its own reference frame (in the reference frame where its axial velocity is zero), is twisted due to the relativity of simultaneity in such reference frames, where this rod moves in one of the axial directions. So, elucidation of the real meaning of this torsion and its effect on the measurement results was one of the objectives of the present work.

### **Digression 1. The rotation of an elastic rod under 'terrestrial' conditions**

At first glance, the torsion of an elastic rod, to which no torque is applied and which is free from internal stresses, appears to be a rather strange phenomenon. In principle, however, there is nothing strange in this phenomenon, which becomes evident if we consider the following 'terrestrial' example.

Let us imagine that between London and Moscow there is a long cylindrical rod with a straight notch extended along the generatrix of the cylindrical surface of the rod. The rod can freely rotate around its axis, without any braking effect of the supports on which it rests. At one point in time  $t_1$  the observers who have arrived from London and who are standing along the rod are beginning to synchronously spin the rod to the angular velocity  $\omega$ , and after the time  $\Delta t$  at the time  $t_2$  simultaneously finish angular acceleration of the rod, leaving it freely rotating. It is clear that if the clocks of all observers are set to show London time  $t$ , then the rod will not experience deformation, and the notch on the surface of the rotating rod remains straight.

Now imagine that besides London observers a great number of local observers are placed along the rod, and the watch of each of them shows precise local solar time. Exchanging information (e.g., on the radio) and analyzing the rotation of the rod, by their solar time, the

observers will detect torsion of the rod expressed through the helical form of the notch on its surface. They will see the cause of torsion in the fact that by their watch in Moscow the spinning of the rod began earlier than that in London. By completion of the spinning of the rod in London, the end of the rod in Moscow will make more revolutions than that in London. If the ends of the rod are fitted with revolution counters, then they will show that in the future the number of revolutions of the end of the rod in Moscow will always exceed that in London. This excess will be the number of revolutions equal to the number of turns of the notch on the surface of the rod. There is nothing mysterious in the torsion of the rod free from internal stresses, because such torsion is a spurious effect due to replacement of true simultaneity with artificial one.

If now you replicate the experiment, provided that the right of spinning the rod has been passed to local observers, then, using their local clocks and ‘simultaneously’ by solar time synchronously starting to spin the rod, they will twist it indeed, causing internal stresses. Upon completion of the spinning of the rod, in order to maintain the angular velocity of the ends of the rod at a constant level, the local observers will be forced to apply counterbalancing opposite torque forces to these ends. However, on the results of comprehensive observations the local observers will find that the notch on the surface of the rod is straight, and by their solar time it is rotating in phase around the axis of the rod. The London observers, having exchanged data and analyzed the spinning of the rod, will register the actual torsion of the rod caused by the fact that at the initial moment of time the rod in Moscow made a certain amount of extra turns.

If the local observers cease to apply torque to the ends of the rod, then the latter on the results of their observations will twist, and the notch on it will take a helical form. In their opinion, further rotation of the rod will occur in the presence of the helix formed by the notch. As to the results of the observations by the London observers, after removing the torque from the ends of the rod it will lose its helical form, the notch will become straight, and further free rotation of the rod will occur without twisting.

In the above example, it is quite simple to separate the actual twisting of the rod from the fictitious one. It is clear that if we spin the rod with a straight notch simultaneously by the universal earth time – be it London or Greenwich Time – then the notch on the surface of the rod will not physically turn into a helix, no matter what the observers equipped with clocks showing local times register. The presence of a helix on an undeformed rod is caused by incorrect clock synchronization along the rod and fictitious simultaneity, shown by these clocks.

In the reviewed example, one should consider real simultaneity the one that is conformity with identical readings of the same revolution counters of the ends of the rod in the free spin mode without internal stresses.

In special relativity, the theme of reality and fictitiousness of relativistic phenomena constantly emerges in discussions of various kinds, but no solution has so far been given. As is generally the case with physics, here the solution to the queuing problems can be eased only by ‘His Majesty’ the experiment.

## **II. The Rotational Clock Synchronization and Torsion of an Elastic Rod**

Let us imagine a long cylindrical elastic rod, the ends of the cylindrical surface of which are graduated with a great number of evenly spaced circumferential strokes (as a scale), and a straight notch along the full length of the generatrix of the cylindrical surface with the ends of this notch falling onto zero strokes of the scales at the ends of the rod.

Let us assume that the edges of the rod are fitted with rotation sensors registering the passage of strokes at the turn of the rod and generating pulses. In a stationary position, the rod

is located so that the zero strokes on both end scales of the rod find themselves opposite the sensors.

We assume that when the rod is subjected to torque, the notch on the cylindrical surface of the rod acquires a helical shape, and after removing the torque, the rod free from residual deformation returns to its initial state, and the notch becomes straight again.

Let at some point in time the rod, staying up to this point in a stationary position, start rotation around the axis of its cylindrical surface, for which purpose one end of the rod - end A - is subjected to torque, while the other end - end B - stays free. Upon reaching the angular velocity of rotation equal to  $\omega_0$ , the preset angular velocity of the given end of the rod is strictly maintained.

Let us assume that each of the sensors located at the ends of the rod detects the passage of the strokes, also generating the pulses sent to a coupled pulse counter. The pulse counter sends data on the number of received pulses to the revolution indicator and to a device, which after fixing the constancy of the angular velocity of the corresponding end of the rod performs the clock function, translating the received number of pulses into the time data. The revolution indicator gives information on the number of revolutions of the rod to a fraction of a turn, set by the density of the strokes at the end scales of the rod.

Initially, while the rod is rotating in an accelerated manner, the angular velocity of the free end B is less than that of the end A due to delay in torque transmission. In this time period, the straight notch on the cylindrical surface of the rod adopts a helical shape. Under sufficiently small angular acceleration of the end A it is only possible to achieve a modest gain in the twist (large enough thread interval) that does not result in excessive deformation and break of the rod. Some time later, the angular velocity of the end B becomes constant and equal to  $\omega_0$ . In the steady state the angular velocity at different positions of the rod cannot be different since the difference of angular velocities of the ends would lead to the gradual 'twisting' and break of the rod. We assume that the freely rotating rod is also free from external braking torques (the rod rotates in a vacuum under zero gravity). Under these conditions, the clocks at the ends of a freely rotating rod with a straight notch are synchronous, and the rotation indicators produce identical readings.

In saying so we believe that prior to the start of the spinning of the end A the pulse counters fitted at both ends of the rod were set to zero and by the time of disappearance of the twist both ends made the same number of turns.

The described synchronization of the clocks moved apart using a freely rotating rod will be called rotational synchronization. The time represented by the readings of the above clocks will be called  $\theta$ -time, and a set of identical readings  $\theta$  on the  $\theta$ -clock – the point of time  $\theta$ .

The clocks synchronized in this way can be used to measure the one-way speed of light - from end A to end B of the rod or vice versa. The clock synchronism does not require arbitrary assumptions as to the nature of the two-way speed of light. Let us introduce the notion of  $\theta$ -simultaneity of events, under which we understand the completion of two or more events at the same time  $\theta$ .

Will  $\theta$ -simultaneity conform to Einstein simultaneity? Will the speed of light measured by pulse clocks on the way from one end to the other end of the rotating rod be equal to the constant  $c$ ?

This question can only be answered by experiment, while we will confine ourselves to arguments relating to the possible and, as we believe, most likely outcome of this experiment.

### **III. The Anticipated Outcome of the Experiment Within the Theory of Special Relativity**

If the postulate of the equality of the two-way speeds of light is physically correct, then the result of measurement of the unidirectional speed of light by a  $\theta$ -clock should be getting the speed value equal to the constant  $c$ . Owing to the equality of inertial reference frames, the result of such an experiment should not be dependable on the choice of the inertial reference frame within which this experiment is to be carried out.

If simultaneity in each inertial frame within special relativity, defined by the equality of oppositely directed speeds of light, is of physical nature, then after bringing the rod into a state of free rotation, the notch in any of these systems should remain straight. This follows from the postulated isotropy of space of any inertial reference frame and from the symmetry of the rod. If the rod is symmetrically brought into a state of rotation, by synchronous, in Einstein's sense, spinning of its ends, then the notch remains straight at any moment of time. If for any reason, be it unidirectional or asymmetrical bidirectional rotation, the spinning of the rod brings about the twist of the notch, then after the rod has passed into a state of free rotation, the elastic forces will straighten the notch. The retaining of the twist in the presence of elasticity and absence of residual deformation is difficult to allow at least for the reason that in the anisotropic space of an inertial system there is no reason for giving preference to a particular direction of the twist.

As in any inertial system no twist of a rotating rod at rest in the axial direction must be present, such twist must appear in inertial reference frames, in which the rod moves in the axial direction. The twist (or 'torsion') of freely rotating rods moving in the axial direction is accounted for by the relativity of simultaneity. We believe that the twist of rotating rods moving in the axial direction and being a purely kinematic effect is not associated with internal stresses, since the latter being absent in one of the reference frames cannot emerge in other systems.

### **IV. The Anticipated Outcome of the Experiment Within Lorentz Ether Theory**

Under the Lorentz ether theory, the physical ether time and the physical ether simultaneity are absolute. The speed of light in physical time is the same in all directions only in the reference frame  $K$ , stationary relative to the ether. Relative to the reference systems moving in the ether, the speed of light in absolute time is different in opposite directions (in the direction of motion of these systems and in the opposite direction). In the ether theory, Lorentz transformations and the resulting relativity of simultaneity appear because of the auxiliary local time introduced into it. The introduction of the local time was thought by Lorentz as a purely mathematical method that had nothing to do with reality. The local time was set in such a way that the local speed of light measured within moving reference frames was the same in opposite directions. The artificial constancy of the unidirectional speed of light in moving inertial reference frames justified the artificially created relativity of simultaneity. Thus, within the ether theory we must take into account the fact that the mathematical form of simultaneity should not apply to physical processes relevant to physical simultaneity.

So, how should the device of the rotational clock synchronization described above behave, when it is at rest in the ether, and when it is moving in it?



If the device  $D$ , which contains the rod  $S$ , is at rest in the ether, the straight notch on the cylindrical surface of the rod  $S$  after bringing it into a state of free rotation must remain straight due to anisotropy of the ether space and because of the symmetry of the rod. For example, if the spinning of the rod  $S$  upon application of torque to one of its ends has resulted in the twist, then after some time this twist should disappear with the torque removed and the rod freely rotating. If the ends of the rod  $S$  spin synchronously by Einstein's time, then the twist of the notch does not appear at all, and the notch during the spinning of the rod stays straight at all moments of time. The one-way speed of light measured by the  $\theta$ -clock must be equal to a constant  $c$ .

What should happen to the device  $D'$  containing a freely rotating rod  $S'$ , if the former moves in the air along a straight line, on which the axis of the rod  $S'$  lies (respectively, it is at rest within the reference frame  $K'$ , which, together with the rod moves along the given line in the ether)?

If we bring the rod  $S'$  to the state of free rotation, then at any moment of physical time in the absence of internal stresses and residual deformations the notch on the rotating rod must be straight. Since in the ether theory the physical point of time is absolute, the straight notch registered in one of inertial reference frames may not turn into a screw in another inertial reference frame. According to the ether theory, this means that the notch on a freely rotating rod can be both straight - and then it will be straight in all reference frames, or helical, for example, during non-synchronous angular acceleration of the rod, and then the twist will also be registered in all inertial reference frames. The synchronism of rotation of the end scales of the rotating rod free from internal stresses in all inertial reference systems is achieved due to the difference of the speeds of light in opposite directions. We can obtain proof of the existence of such a difference by measuring the speeds of light in the opposite direction by means of the  $\theta$ -clock. Upon measuring these speeds, changing the orientation of the rod in space, it is easy to calculate the travel speed of the proper reference frame in the ether.

Measurement of the absolute velocity of the proper reference frame is also possible in a different way. If in the absolute ether time the notch on the rotating rod moving in the axial direction is straight, then in Einstein time it is helical. The degree of the twist depends on the speed of the movement of the rod. In principle, this makes it possible to determine the torsion of the rod in Einstein time, and hence to calculate the speed of the proper reference frame.

## **Digression 2. A Strange Torsion of the Rod in the Absence of Internal Stresses**

Mentioning the impossibility of measuring the one-way speed of light without arbitrary assumptions, and making such an assumption, Einstein was inclined to consider an alternative arbitrary assumption of the inequality of the speed of light in opposite directions as unnatural and 'most unlikely'.

This Einstein's statement is difficult to accept. It is the assumption of the equality of the two-way speeds of light in reference frames moving relative to each other that looks 'unnatural', because it did not occur to the majority of pre-Einstein physicists and therefore arouses scepticism these days. As for low probability of the inequality of the speeds of light in opposite directions, this Einstein's conclusion is a different form of his subjective conclusion about the unnaturalness of this inequality. An analysis of the behaviour of a freely rotating rod, free from internal stress, in different inertial systems just shows unnaturalness and low probability of the equality of the two-way speeds of light.

Let us consider the device  $D$  at rest in the reference frame  $K$ , containing the rod  $S$ , and the device  $D'$  containing the rod  $S$  and at rest in the reference frame  $K'$ .

Suppose that in the inertial reference frame  $K$  unidirectional speeds of light, measured by the  $\theta$ -clock of the device  $D$ , were the same in all directions. In this case, we can say that the  $\theta$ -clock is synchronous in Einstein's sense as well. Such synchronism, being universal for all inertial reference frames, is true in the ether model for an absolute stationary reference frame. Suppose that after measuring the one-way speed of light by the  $\theta$ -clock and clock synchronization throughout the reference frame  $K$ , the rotation of the rod is stopped and it is moved to a stationary position in which the zero-reset rotation sensors are positioned against the zero notches of the end scales of the rod. Suppose also that the devices providing the spinning of the rod are installed along the rod at different points of the reference frame  $K$ .

At some point of time all devices are triggered simultaneously, providing a uniform angular acceleration  $\epsilon$  to the nearby areas of the rod. The synchronism of acceleration provides a synchronic increase in the angular velocity of the rod. Having worked for the time  $\Delta t$ , all devices are simultaneously turned off, and the rod goes into a state of free rotation with angular velocity  $\omega = \epsilon \Delta t$ .

We assume that due to in-phase rotation of all areas of the rod the notch on the surface of the rotating rod, moving around the axis of the rod, remains straight in the reference frame  $K$ . The rotation counters fitted at the ends of the rotating rod at the moment of switching the spinning devices off will show the same number of revolutions made by this moment.

In the reference frame  $K'$ , whose clock is also synchronized in the Einstein way, and the rod  $S$  moves in the axial direction, the notch due to the relativity of simultaneity becomes helical. Why does a straight notch on a rod moving in the axial direction while spinning turn into a spiral notch?

This occurs for the following reason.

Due to relativity of simultaneity in the reference frame  $K$  the clock moving with the reference frame  $K'$  and located at the rear end of the rod in the direction of motion, is leaving behind the moving clock found at its front end. For this reason, the spinning device at the rear end of the rod is triggered before the spinning device at its front end, and the rod with the notch twists. This process becomes evident, if we assume that the length of the rod is such that in the reference frame  $K'$  it holds one full coil of the helical notch (the length of the rotating rod moving in the axial direction is equal to the pitch of the screw). Then a misalignment between the spin-up of the front and rear ends of the rod will lead to the fact that by the end of the spin of the rod, which coincides with the moment of disconnection of spinning device at the front end, the rear end of the rod will make one revolution more than its front end. The further free rotation of the rod in the reference frame  $K'$  will be in its twisted condition, and the rod will not be subjected to internal stresses and will not seek to leave the state of torsion. The absence of internal stresses in the rod occurs due to the fictitious nature of its torsion, similar to the fictitious nature of the torsion of the rod in the example we have considered in the digression.

## Conclusion

Despite a widespread opinion that it is impossible to measure the one-way speed of light, attempts to carry out this measurement continue to this day. It is regrettable that the results of such experiments receive so little attention that even validation of the results, which have already been carried out, for example, those of S. Marinov, entails complications. At the same time, the given analysis of the possibility of measuring the one-way speed of light using a

synchronously rotating disks or graduated scales shows that such measurement is possible if in-phase rotation of the disks or scales takes place in a natural way by means of a freely rotating rod, not subjected to internal stresses. The effect of torsion of a rotating rod in different reference frames on the measurement of the one-way speed of light examined in this paper requires further consideration of the behavior of the rotating rod in gravitational fields and in accelerating non-inertial reference frames.

## References

1. Marder, L. (1971) *Time and the Space-Traveller*, Philadelphia.
2. A.A. Tyapkin. *Uspekhi Fiziceskih Nauk*, Moscow, 1972, 106, p. 617-659
3. A.A. Logunov. *Lectures on the theory of relativity and gravitation: Contemporary analysis of the problem*, Moscow, Izdatel'stvo Nauka, 1987
4. Brillouin L. *Relativity Reexamined*. 1972. Academic. London Press. 1970. (Cited from: Brillouin L. A new look at the theory of relativity. Moscow, Mir Publisher
5. L. Karlov. *Australian journal of physics*. 23, 1970, p. 243-253.
6. Einstein, A (1905). "*Zur Elektrodynamik bewegter Körper*". *Annalen der Physik* (in German) : English translation: Perrett, W; Jeffery, GB (tr.); Walker, J (ed.). "*On the Electrodynamics of Moving Bodies*" , Fourmilab
7. H.Reichenbach,. *Philosophie der Raum-Zeit-Lehre*. English translation: Maria Reichenbach, *The Philosophy of Space and Time*. 1957, Dover.
8. V.N. Matveev. *Into the third Millennium without Physical Relativity?* Moscow, CeRo Publishers, 2000.
9. S. Marinov, *Gen. Rel. Grav.* 12, 57 (1980).
10. S. Marinov, *Found. of Phys.* 8, 137 (1978).
11. Md. Farid Ahmed and others, 2011, To Re-Consider the One-Way Speed of Light Using Fizeau-Type-Coupled-Slotted-Disks <http://arxiv.org/abs/1103.6086>
12. Md. Farid Ahmed and others, 2013, Results of a one-way experiment to test the isotropy of the speed of light <http://arxiv.org/abs/1310.1171>