

Bh

Correction to Vixra paper 1411.0078v1

Non local signaling based on quantum eraser:

The quantum eraser transmitter will work as following:

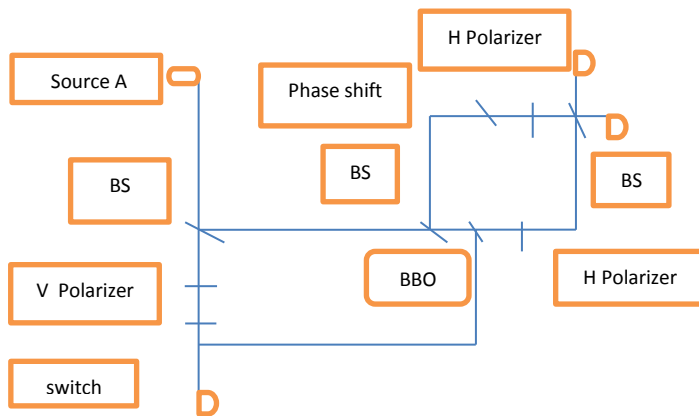

Fig 1: Photons emitted from source to beam splitter with 50 % probability of continuing to the V polarized, passing through the switch to detector one. 50% probability of continuing to the Mach Zehnder interferometer, where it has a 50% of reaching the BBO, the polarizer, the beam splitter and one of the detectors 2 or 3. Another 50% probability is for it to pass through course B, where it will undergo a phase shift, polarized and through the beam splitter to detectors 2 or 3. However, we are able to adjust the interferometer so that only Detector 2 will receive light and detector 3 will remain dark due to an absolutely destructive interference.

In a regular case no which way information is present. The entangled photon continues straightly to detector 1, however it could have come from a different course, therefore it is not considered a measurement. We cannot know which path did this photon take, therefore no measurement had been made, and the photons in the Mach Zehnder interferometer remain in a wavelike form. Detector 2 yet receives no light.

However, if the switch is set to be open, the idler photon could have come only from the course with the BBO present in. As in the Elitzur Weidman Mach Zehnder interferometer, now we have which way information and the photons behave particle like.

There is now a 50% probability that detector 2 will receive light. In this case, Bob sent a $\langle 1 \rangle$.