

Investigation of Direct Coupled Induction Generator Performance under Normal and Fault Conditions-Modelling and Simulation

Umashankar S, Sujyothi P, Nithya V G, Vijayakumar D and Kothari D P

School of Electrical Engineering, VIT University, Vellore - 632014, Tamil-Nadu, India

Abstract: This paper shows an induction generator based wind power generation. This system has the voltage source converter excited induction generator for wind power generation. This is one of the investigations of possible combination of the induction generator for wind power and the power electronics equipments. Induction generator is popularly used for the wind power generation. The disadvantages of it are impossible to generate power at the lower rotor speed than the synchronous speed. To compensate this disadvantage, expensive synchronous generator with the permanent magnets sometimes used. In proposed system, the VSC is used to convert the real power from the induction generator to the intermediate dc power, while the reactive power necessary to excite the induction generator is supplied from grid side through VSC only.

For the proposed system the future work may be extended by using the diode rectifier in parallel with low rated VSC. The diode rectifier converts real power from the induction generator, the reactive power is supplied from grid through the lower rated VSC. Thus the rating of the expensive VSC is minimized and total cost of the wind power generation system is decreased compared to the existing system with induction generator and synchronous generator.

KEY WORDS: Wind power generation system, Voltage source converter, Converter control, Simulation, Synchronous and Asynchronous generators.

1 Introduction

Now a day in the several forms of renewable energies available, wind energy will be cost effective for the future. In fact in keeping view of present running systems we can say that it has been almost achieved. As we don't know the future cost of fossil fuels exactly but it will be certainly more than present rates. To create the generation of wind power more effective lot of changes and improvements are needed. Mainly reducing the cost and improving the output is the fundamental issue. This topic shows how to achieve more power through induction generator by using aback to back voltage sourced converter system for excitation of induction machine. The induction generator is the most reliable popular and the less cost machine for the wind power generation. Disadvantage it will not generate power at speeds lower than the synchronous speed. The synchronous generator with the permanent magnets will generate power at any speed, but it is costly compared with this system. Therefore we have proposed to use the induction generator with back to back VSC system.

2 Modern Wind Turbine

The power output, P, from a wind turbine is given by the well-known expression

$$P = \frac{1}{2} C_p \rho A U^3 \quad (1)$$

where ρ is the density of air (1.225 kg/m³), C_p is the power coefficient, A is the rotor swept area, and U is the wind speed.

The density of air is rather low, 800 times less than that of water which powers hydro plant, and this leads directly to the large size of a wind turbine. Depending on the design wind speed chosen, a 1.5 MW wind turbine may have a rotor that is more than 60 m in diameter. The power coefficient describes that fraction of the power in the wind that may be converted by the turbine into mechanical work. It has a theoretical maximum value of 0.593 (the Betz limit) and rather lower peak values are achieved in practice. The power coefficient of a rotor varies with the tip speed ratio (the ratio of rotor tip speed to free wind speed) and is only a maximum for a unique tip speed ratio. Incremental improvements in the power coefficient are continually being sought by detailed design changes of the rotor and, by operating at variable speed, it is possible to maintain the maximum power coefficient over a range of wind speeds. However, these measures will give only a modest increase in the power output. Major increases in the output power can only be achieved by increasing the swept area of the rotor or by locating the wind turbines on sites with higher wind speeds.

3 Wind Generating Systems

3.1 Fixed Speed System

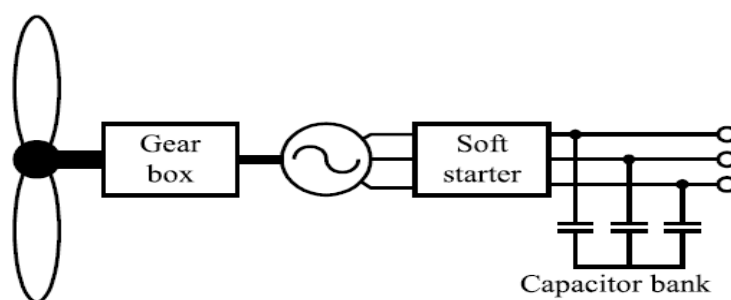

Fig 1. Fixed speed wind conversion system

In the early 1990s the standard installed wind turbines operated at fixed speed. That means that regardless of the wind speed, the wind turbine rotor speed is fixed and determined by the frequency of the supply grid, the gear ratio and the generator design. It is characteristic of fixed-speed wind turbines that they are equipped with an induction generator (squirrel cage or wound rotor) that is directly connected to the grid, with a soft-starter and a capacitor bank for reducing reactive power compensation. They are designed to achieve maximum efficiency at one particular wind speed. In order to increase power production, the generator of some fixed-speed wind turbines has two winding sets: one is used at low wind speeds (typically 8 poles) and the other at medium and high wind speeds (typically 4–6 poles).

3.2 Variable Speed System

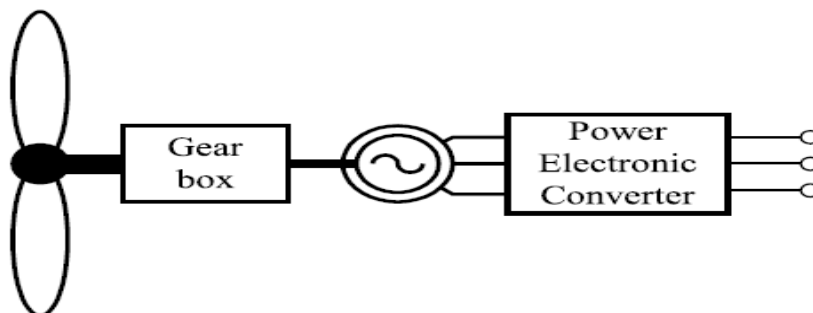

Fig 2. Variable speed wind conversion system

During the past few years the variable-speed wind turbine has become the dominant type among the installed wind turbines. Variable-speed wind turbines are designed to achieve maximum aerodynamic efficiency over a wide range of wind speeds. With a variable-speed operation it has become possible continuously to adapt (accelerate or decelerate) the rotational speed of the wind turbine to the wind speed v . This way, the tip speed ratio λ is kept constant at a predefined value that corresponds to the maximum power coefficient. Contrary to a fixed-speed system, a variable-speed system keeps the generator torque fairly constant and the variations in wind are absorbed by changes in the generator speed.

The advantages of variable-speed wind turbines are an increased energy capture, improved power quality and reduced mechanical stress on the wind turbine. The disadvantages are losses in power electronics, the use of more components and the increased cost of equipment because of the power electronics. The introduction of variable-speed wind-turbine types increases the number of applicable generator types and also introduces several degrees of freedom in the combination of generator type and power converter type.

3.3 Asynchronous Generator

The most common generator used in wind turbines is the induction generator. It has several advantages, such as robustness and mechanical simplicity and, as it is produced in large series, it also has a low price. The major disadvantage is that the stator needs a reactive magnetising current. The asynchronous generator does not contain permanent magnets and is not separately excited. Therefore, it has to receive its exciting current from another source and consumes reactive power. The reactive power may be supplied by the grid or by a power electronic system. The generator's magnetic field is established only if it is connected to the grid.

In the case of AC excitation, the created magnetic field rotates at a speed determined jointly by the number of poles in the winding and the frequency of the current, the synchronous speed. Thus, if the rotor rotates at a speed that exceeds the synchronous speed, an electric field is induced between the rotor and the rotating stator field by a relative motion (slip), which causes a current in the rotor windings. The interaction of the associated magnetic field of the rotor with the stator field results in the torque acting on the rotor. The rotor of an induction generator can be designed as a so-called short-circuit rotor (squirrel cage rotor) or as a wound rotor.

3.4 The Back To Back Converter

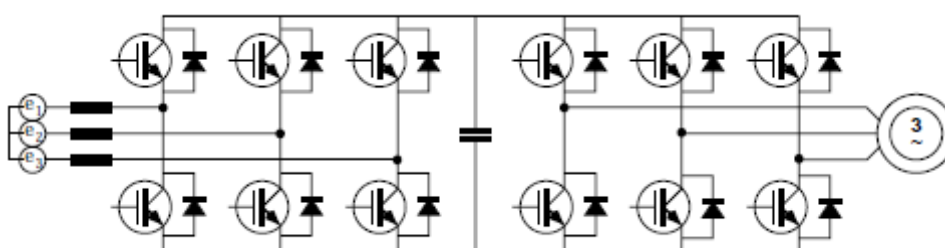

Fig. 3 Back To Back Converter System

The back-to-back converter is indicated at in the above introduction. It consists of a force commutation rectifier and force commutation inverter both connected with a dc-link as shown in the above figure 3. The operation of this combination is well known that is the line-side converter will be operated to give sinusoidal line currents and for this sinusoidal currents the dc-link voltage must be higher with respect to peak main voltage, the dc-link voltage is regulated by controlling the power flow to the ac grid and now the inverter operates on the dc-link side making it possible to increase the output power of a connected machine over its rated power. One more advantage in some applications is that braking energy can be fed back to the power grid instead of just wasting it in a braking resistor.

Most important property of the back-to-back converter is controlling the power flow fast. By controlling the power flow towards the grid, the dc-link voltage can be maintained constant. With the presence of a fast control loop for the dc link voltage makes it possible to reduce the size of dc-link capacitor, without affecting the inverter performance.

4 Proposed System

In the proposed system we have induction generator with and for the controlling of VSC we have used PWM technique.

The induction generator will initially acts as a motor and after building up the speed above the synchronous

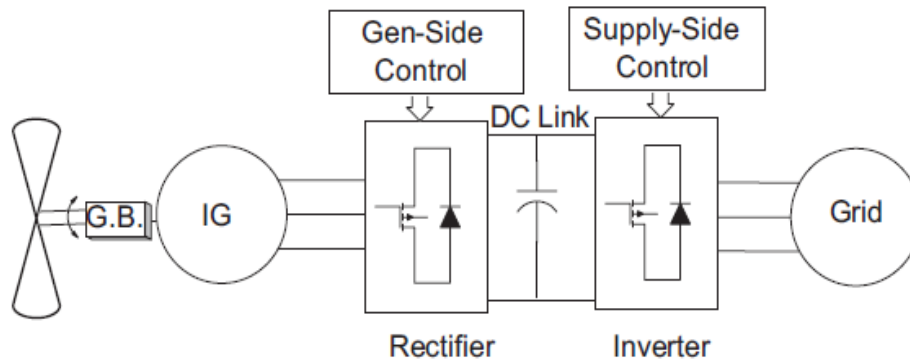

Fig. 4 Wind Generation System Setup

speed it will act as a induction generator. It will absorb the required reactive power form the grid and delivers the active power to the grid. Universal bridge has been used for VSC in this system in which the generator side bridge will act as rectifier and the grid side bridge will act as inverter.

5 Active and Reactive Power Observations in Fixed Speed System

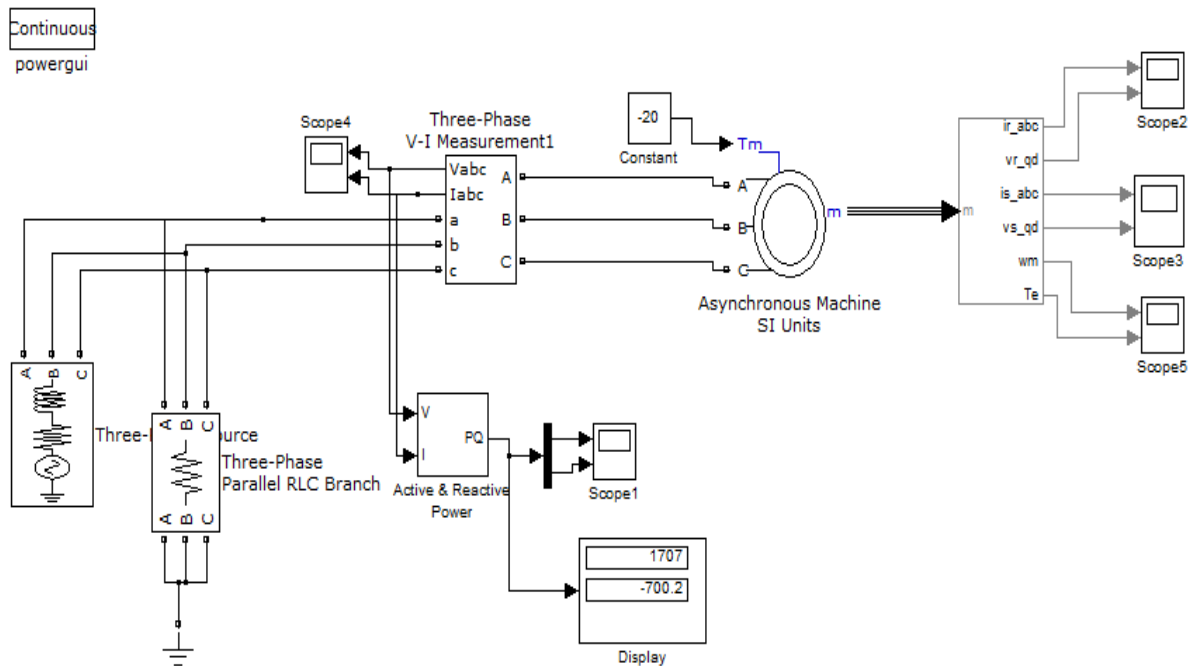

Fig. 5 Simulation Of Fixed Speed System

5.1 Simulation Graphs for Fixed Speed Generator

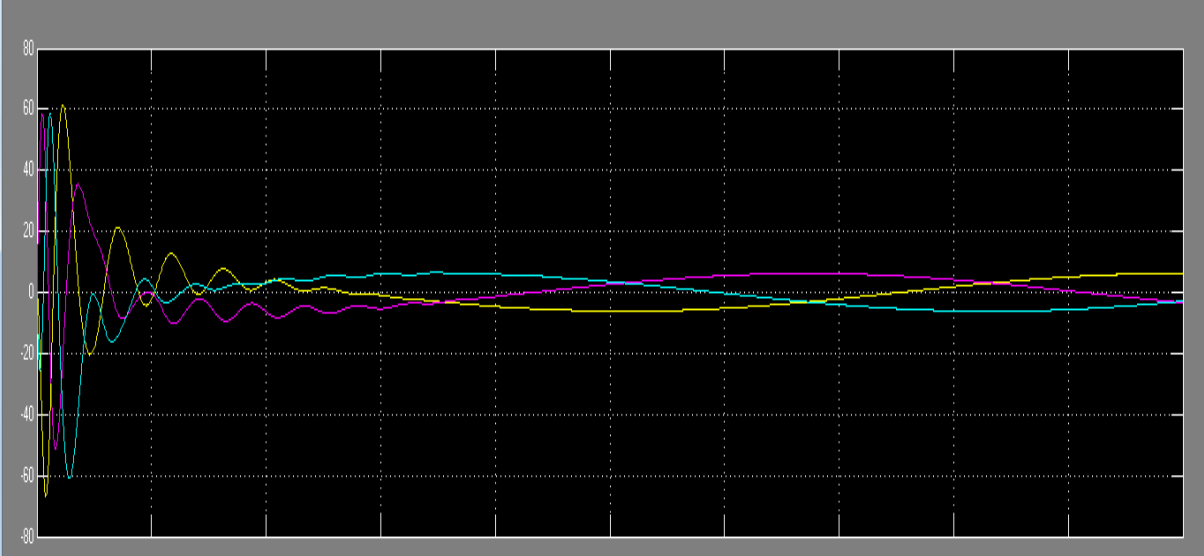

Fig. 6 Rotor Current

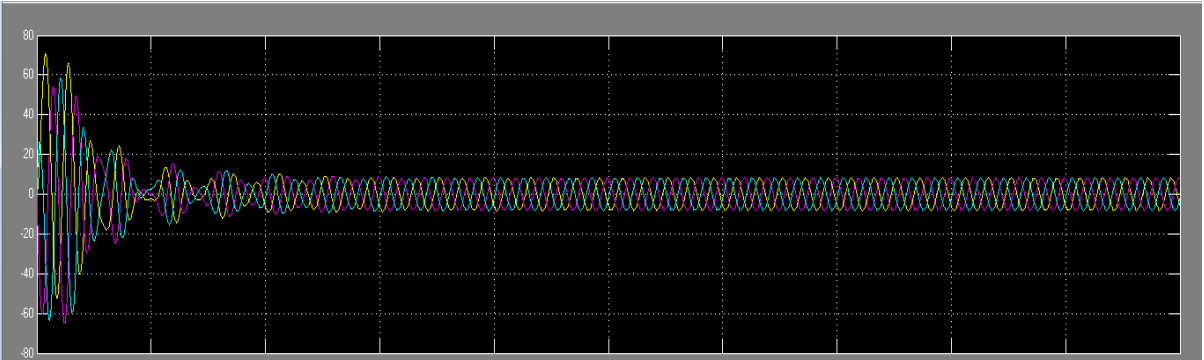

Fig.7 Stator Current

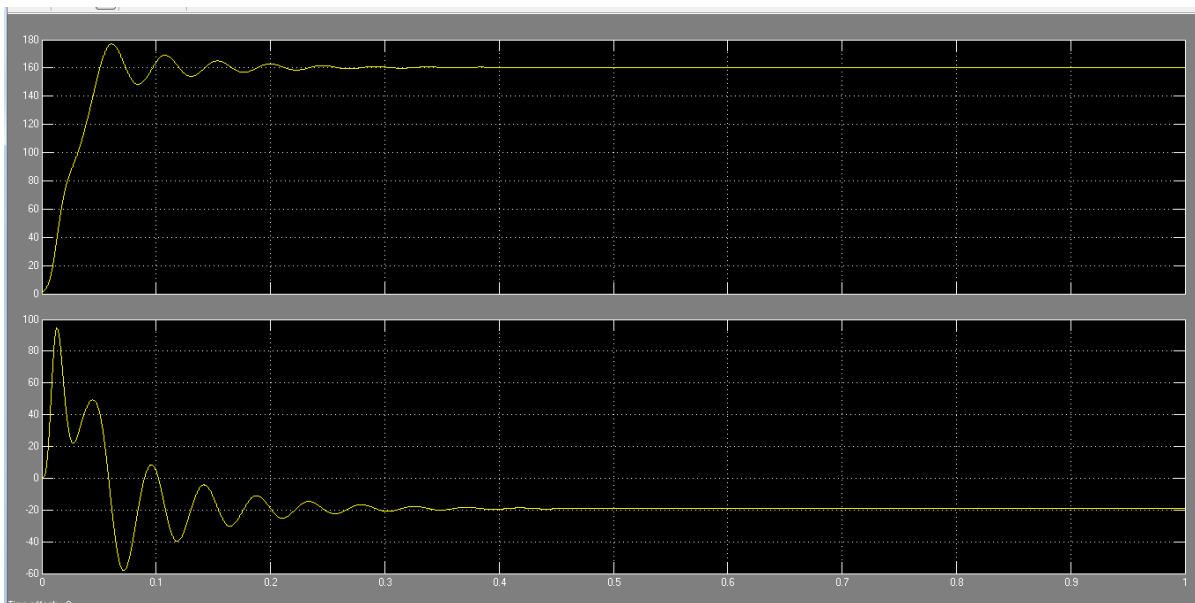
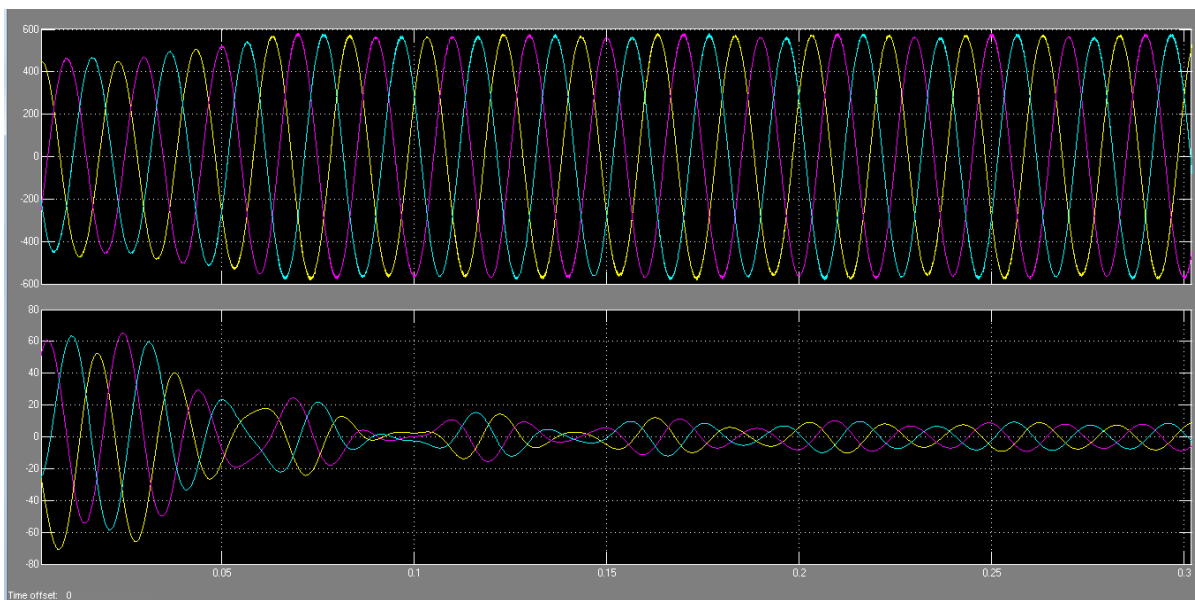

Fig. 8 Speed and Torque Wave Forms



5.2 Active and Reactive Power Flow

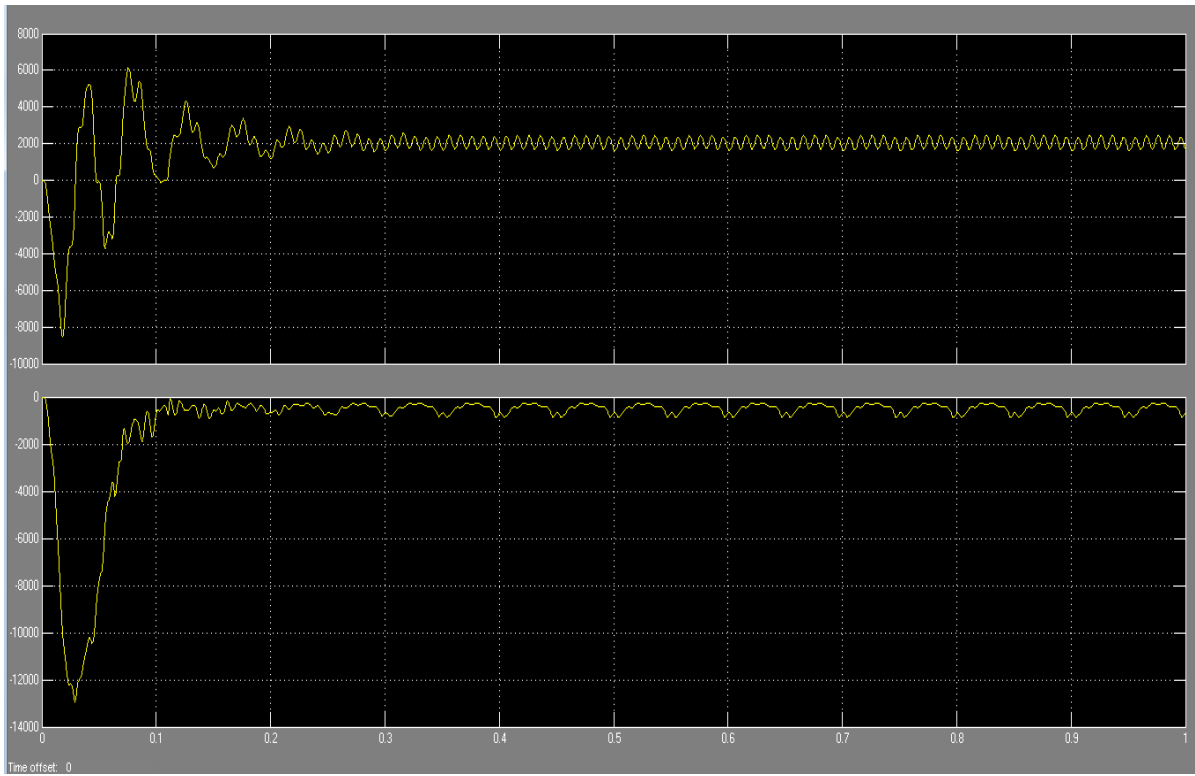

Fig.9 Active and Reactive Power Flow

6 Active and Reactive Power Observations in Variable Speed System

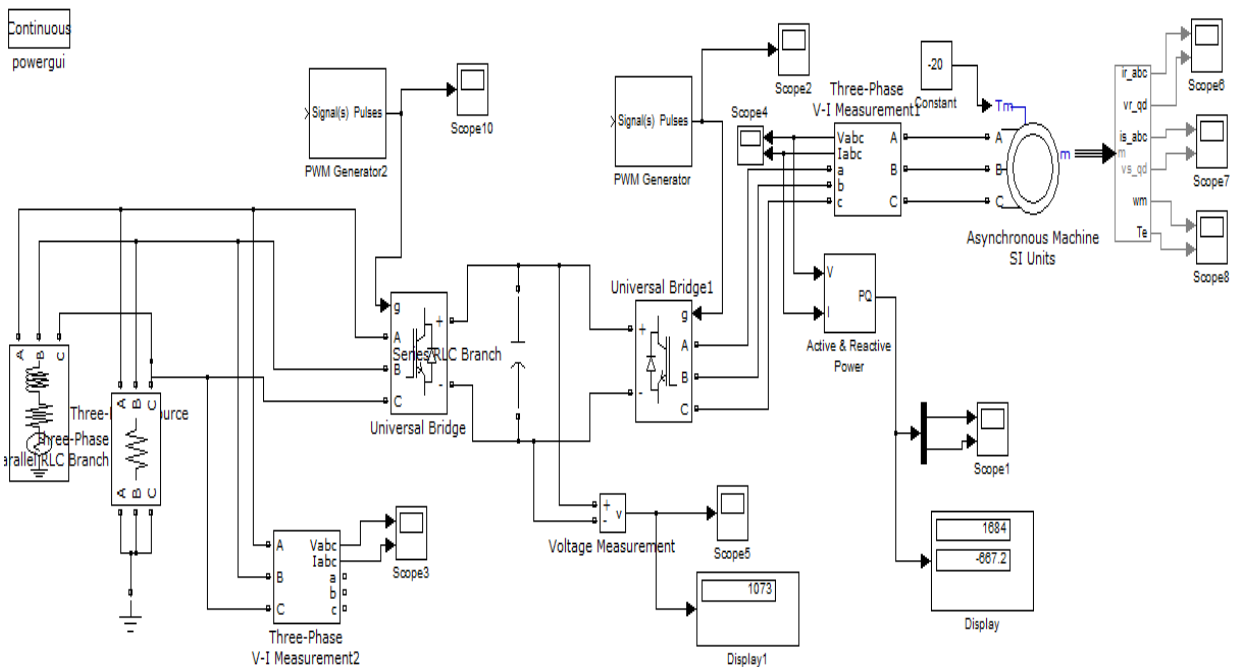

Fig. 10 Simulation of Variable Speed System

6.1 Simulation Graphs for Variable Speed System

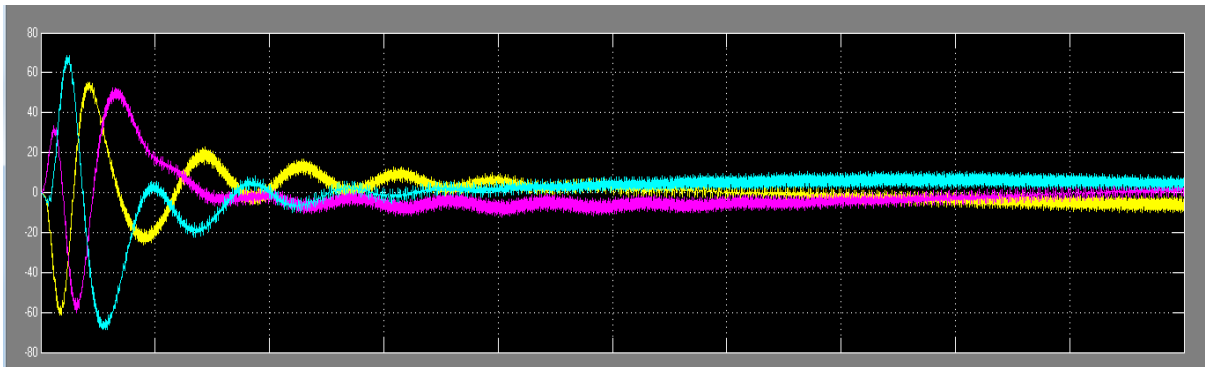

Fig. 11 Rotor Current

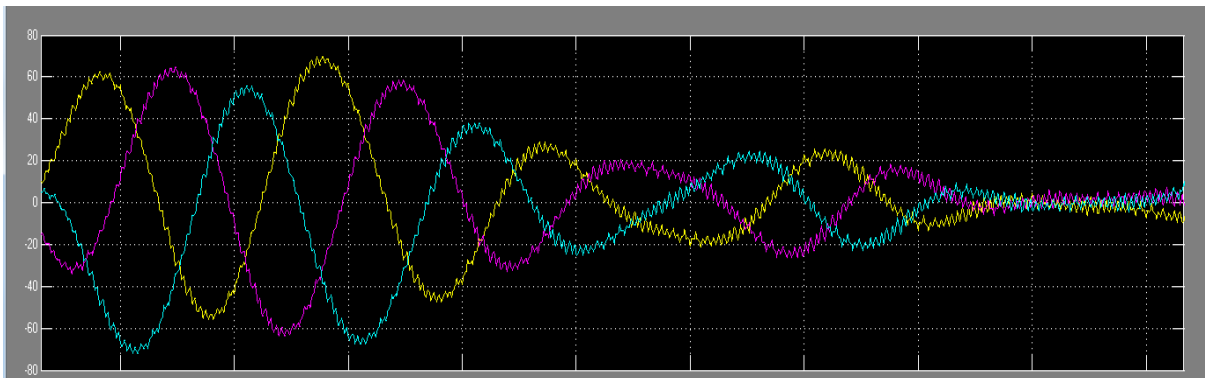

Fig. 12 Stator Current

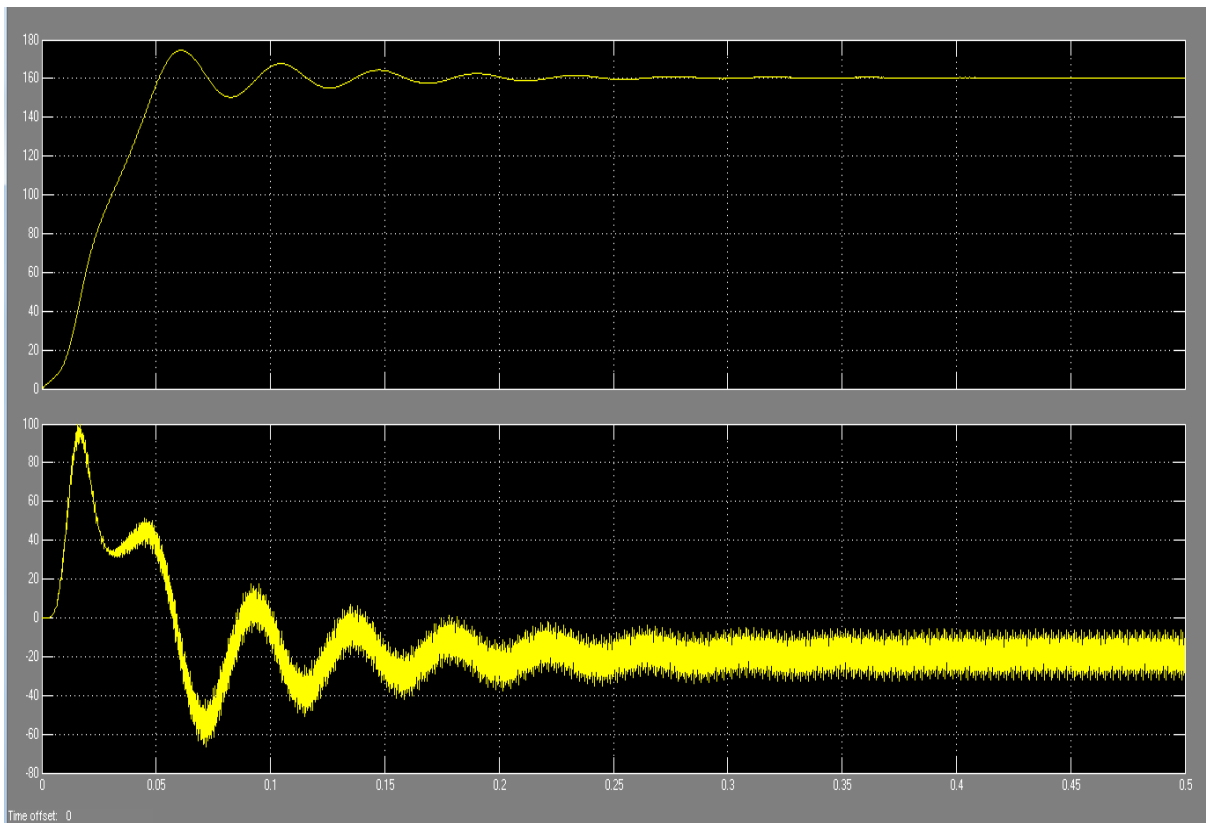

Fig. 13 Speed and Torque

6.2 Active and Reactive Power Observation

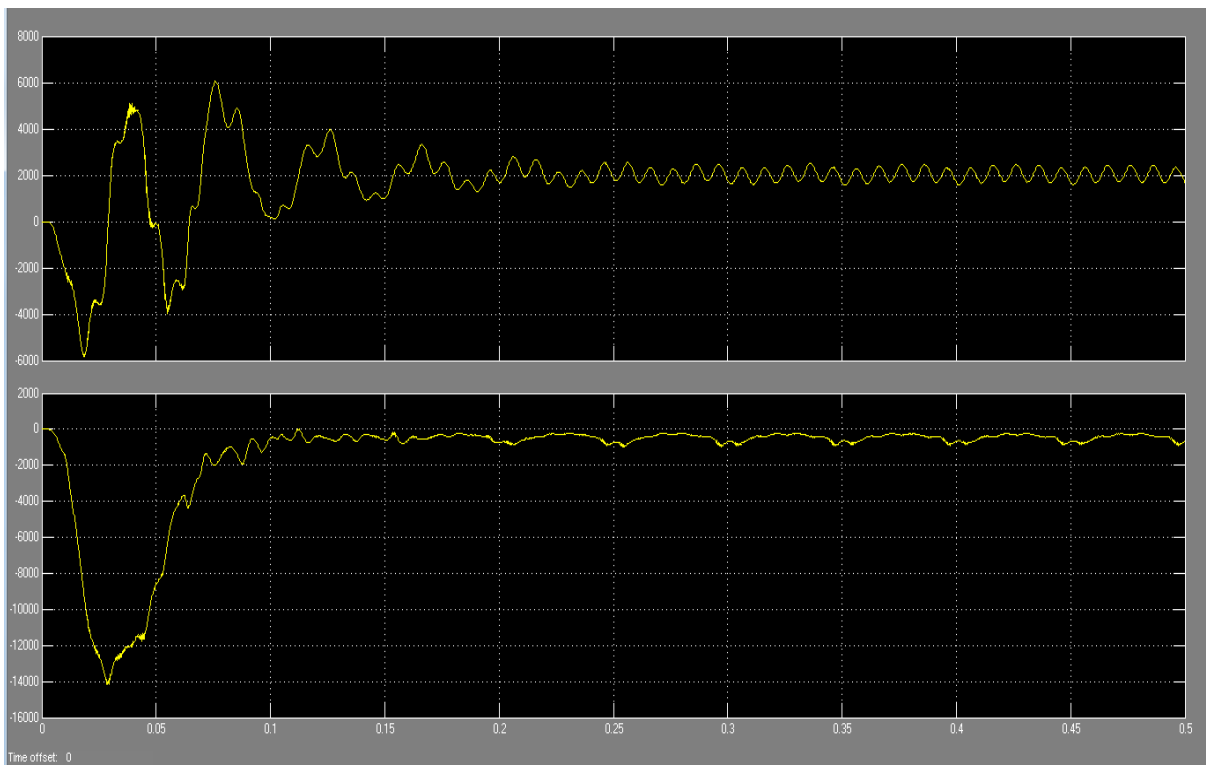

Fig.14 Active and Reactive Power

7 Voltage and Current Wave Forms Of Generator Side

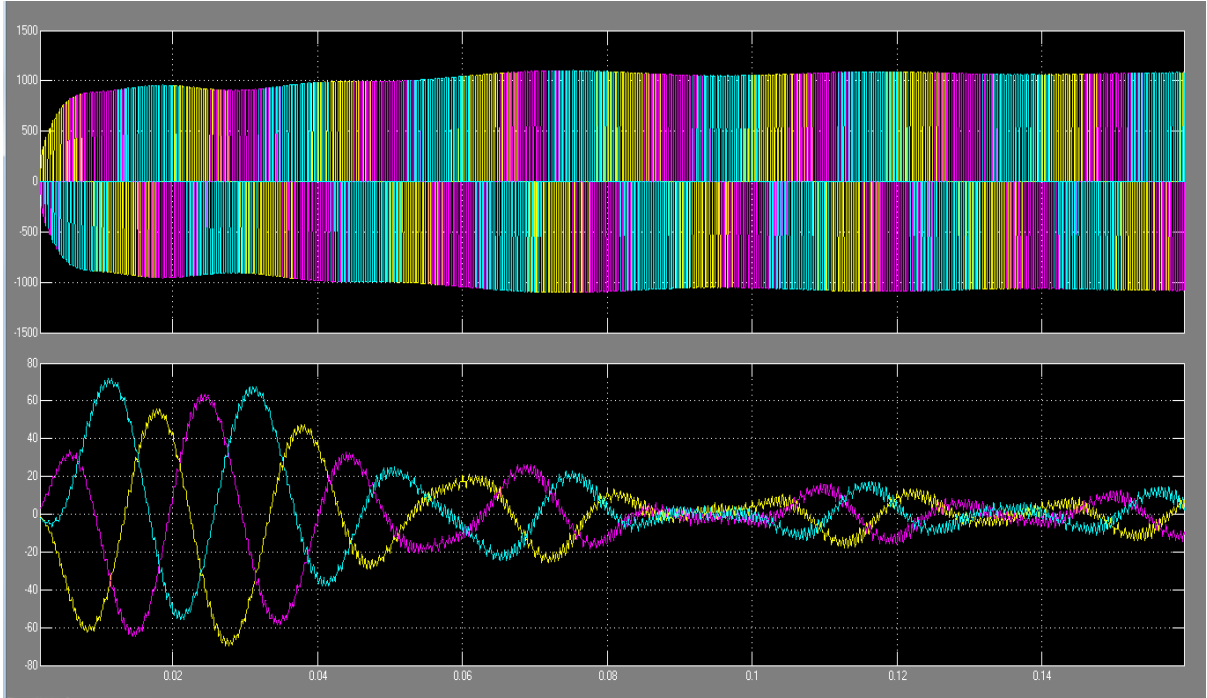

Fig.15 Voltage and Current Generator Side

8 Dc Link Voltage

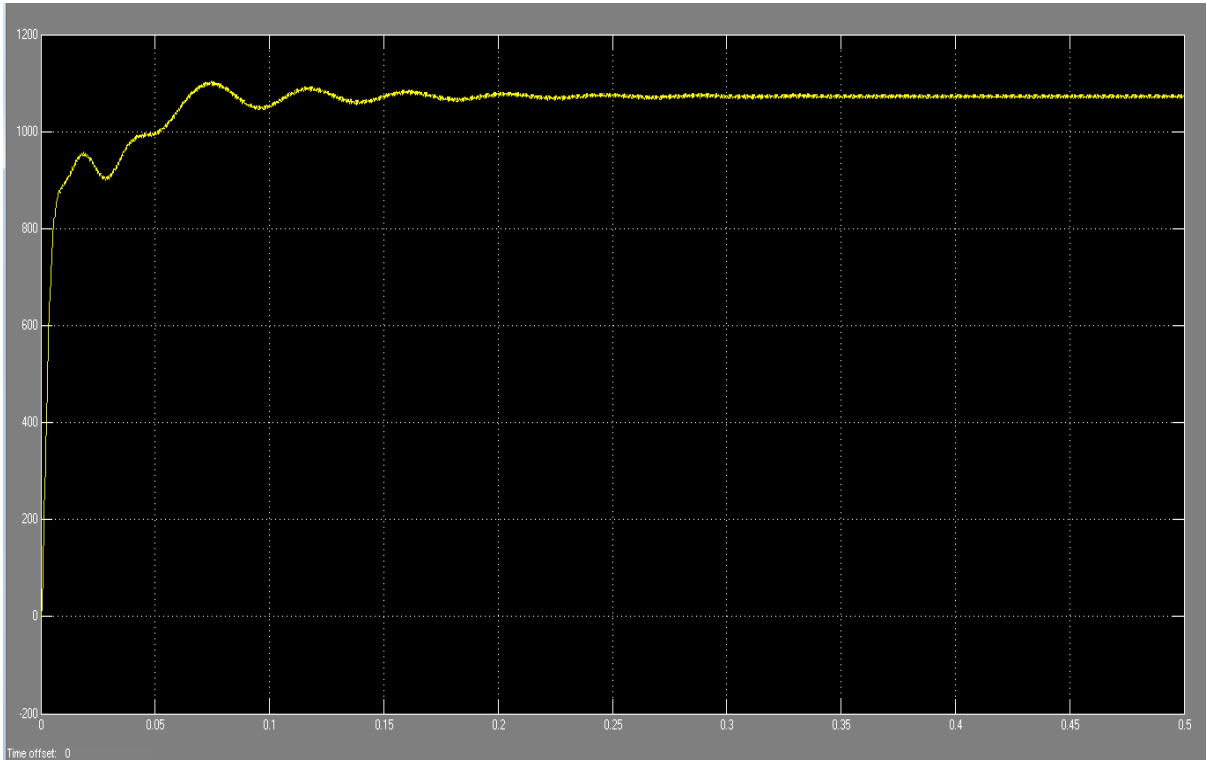

Fig. 16 Dc Link Voltage

9 Voltage and Current Wave Forms Of Grid Side

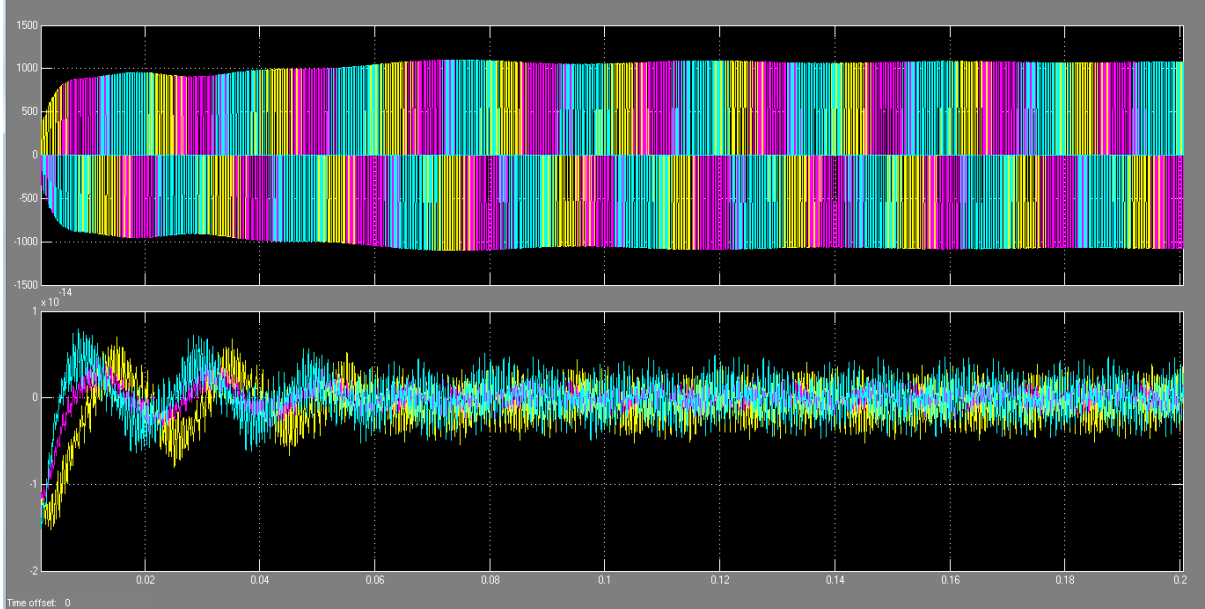

Fig. 17 Voltage and Current Grid Side

10 Pulse Generator

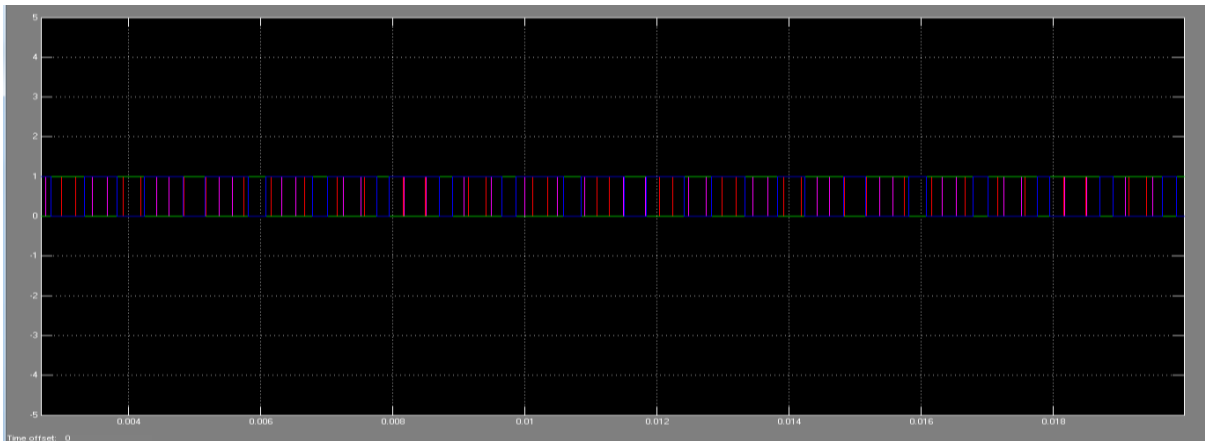

Fig. 18 Pulse Generator

11 Conclusions

Here we can say that by using fully controlled VSC containing IGBT (universal bridge) the flow of the reactive power required for the induction generator initially when it acts as motor and for the supply of active power to the grid when it is acting as the generator is studied and for the proposed system the future work may be extended by using the diode rectifier in parallel with low rated VSC. The diode rectifier converts real power

from the induction generator, the reactive power is supplied from grid through the lower rated VSC. Thus the rating of the expensive VSC is minimized and total cost of the wind power generation system is decreased compared to the existing system with induction generator and synchronous generator.

References

1. Noriyuki Kimura, Tomoyuki Hamada, Toshimitsu Morizane and Katsunori Taniguchi: Control of PFC Converter with Inverter Excited Induction Generator for Advanced Wind Power Generation. 2008 IEEE
2. Noriyuki Kimura, Mitsuhiro Hirao, Toshimitsu Morizane, Katsunori Taniguchi: Wind Power Generation System with Induction Machine and Diode Rectifier. EPE-PEMC 2006, 12th International Power Electronics and Motion Control Conference, T12-115 (2006-8)
3. Jhon Sevansson: Grid connected voltage source converter, Chalmers University of Technology
4. Mukund.R.Patel : Wind and solar power systems, Ph.D., P.E
5. Anders Carlsson : The back to back converter control and design