

Boson Charge Explained

By John Frederick Sweeney

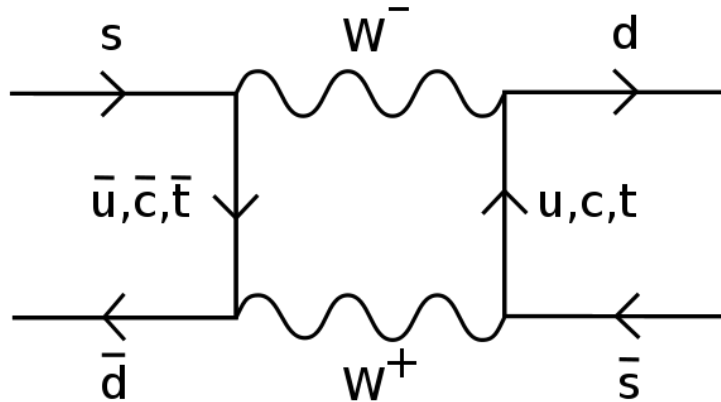
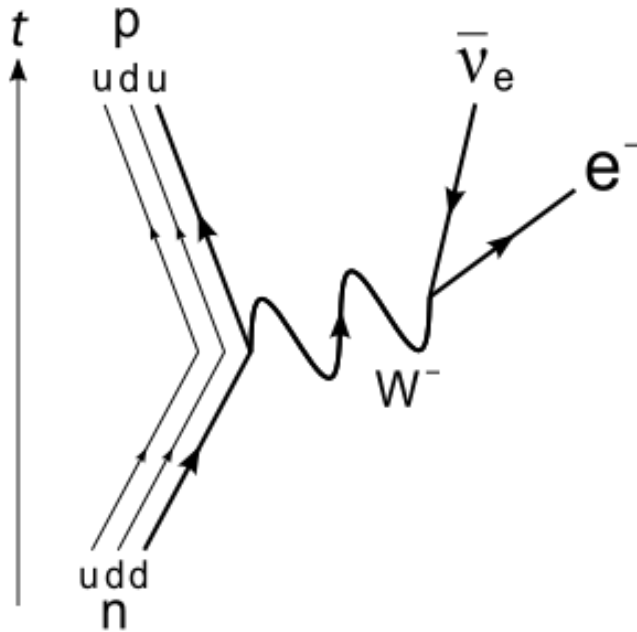

Abstract

Bosons come in positive, negative and zero charges, W^+ , W^- and Z , but western science to date fails to explain why this is so. The W^+ , W^- , and Z^0 bosons, together with the photon (γ), comprise the four gauge bosons of the electroweak interaction. Vedic Physics offers the genuine explanation of why bosons have three distinct types of charge and this paper definitively explains the reason, which has to do with the three types of matter in the Universe. The paper concludes with a new typology of bosons based on the three different types of matter found in the universe.

Table of Contents

Introduction	3
Bosons in Western Physics	4
W' and Z' bosons (W-prime and Z-prime bosons)	6
<hr/>	
Bosons in Vedic Physics	7
Conclusion	8
Appendix	9
Bibliography	12

Introduction

According to Everything2 website:

The Z particle is one of the intermediate vector [bosons](#), a pair of particles predicted in 1979 in order to unify two of the fundamental forces: the [electromagnetic](#) and [weak forces](#) into the [electroweak force](#). The Z particle has no electric charge, but is otherwise very similar to the [W particle](#).

The precise reasons for the large difference in [mass](#) is unknown. They were detected at [CERN](#) in 1982 and the Z particle's mass was measured at 93GeV.

Thus we have known about these particles for some 45 years but still cannot explain much about them, and work with them requires larger and larger particle smashers.

This author has written a series of papers about Vedic Physics, primarily based on the work of one author. This paper expands sources to a second book published in India that is difficult to find and the author impossible to contact. Yet, as Gertrude Stein said of Oakland, California, there is a there there.

In other words, both of these books purport to decode Sanskrit literature about the Vedas in order to relate fundamental theorems about Vedic Physics. The second book relies primarily on verses from the Rig Veda, which physicist Frank "Tony" Smith has properly identified as the source of great things. Perhaps the world needed to wait for the period when western science began to solve the mysteries of atoms and subatomic particles before Indian scholars could divulge the secrets contained within Vedic Literature.

This book reveals a simple set of facts about bosons, which carry enormous implications for particle physics. Whether or not the particle physicists will heed this clue remains to be seen, yet it will go a long way in explaining the heretofore inexplicable about bosons and other aspects of the Universe.

This paper first gives Wikipedia entries for subjects related to bosons, based on contemporary understanding. Then, the paper briefly gives the Vedic interpretation, and finally, concludes with a brief discussion of the implications for future research, with a new typology of bosons based on the three different types of matter in the universe.

Bosons in Western Physics

Wikipedia provides this entry:

The **W and Z bosons** (together known as the **weak bosons** or, less specifically, the **intermediate vector bosons**) are the **elementary particles** that **mediate** the **weak interaction**; their symbols are W^+ , W^- and Z . The W bosons have a positive and negative **electric charge** of 1 **elementary charge** respectively and are each other's **antiparticles**. The Z boson is electrically **neutral** and is its own antiparticle. All three of these particles are very short-lived with a **half-life** of about 3×10^{-25} s.

Their discovery was a major success for what is now called the **Standard Model** of **particle physics**.

The W bosons are named after the weak force. The **physicist Steven Weinberg** named the additional particle the "Z particle",^[2] later giving the explanation that it was the last additional particle needed by the model – the W bosons had already been named – and that it has zero electric charge.^[3]

The two W bosons are best known as mediators of **neutrino** absorption and emission, where their charge is associated with electron or positron emission or absorption, always causing **nuclear transmutation**. The Z boson is not involved in the absorption or emission of electrons and positrons.

The Z boson is most easily detected as a necessary theoretical force-mediator whenever neutrinos scatter *elastically* from matter, something that must happen without the production or absorption of new, charged particles. Such behaviour (which is almost as common as inelastic neutrino interactions) is seen in **bubble chambers** irradiated with neutrino beams.

Whenever an electron simply "appears" in such a chamber as a new free particle suddenly moving with kinetic energy, and moves in the direction of the neutrinos as the apparent result of a new impulse, and this behavior happens more often when the neutrino beam is present, it is inferred to be a result of a neutrino interacting directly with the electron.

Here, the neutrino simply strikes the electron and scatters away from it, transferring some of the neutrino's momentum to the electron. Since i) neither neutrinos nor electrons are affected by the **strong force**, ii) neutrinos are electrically neutral (therefore don't interact electromagnetically), and iii) the incredibly small masses of these particles make any gravitational force between them negligible, such an interaction can only happen via the weak

force. Since such an electron is not created from a nucleon, and is unchanged except for the new force impulse imparted by the neutrino, this weak force interaction between the neutrino and the electron must be mediated by a weak-force boson particle with no charge. Thus, this interaction requires a Z boson.

A linked Website offers this:

Intermediate Vector Bosons

The [W and Z particles](#) are the massive [exchange](#) particles which are involved in the nuclear [weak interaction](#), the weak force between electrons and neutrinos. They were predicted by Weinberg, Salam, and Glashow in 1979 and measured at [CERN](#) in 1982. The prediction included a prediction of the masses of these particles as a part of the unified theory of the electromagnetic and weak forces, the [electroweak unification](#). "If the weak and electromagnetic forces are essentially the same, then they must also have the same strength. The fact that the experimentally observed strengths seem quite different is attributed to the masses of the W and Z particles—under certain conditions a force of large strength can have the appearance of a force of small strength if the particle that carries the force is very massive. Theoretical calculations show that at a fundamental level the weak and electromagnetic forces have the same strength if the W and Z particles have masses of 80 and 90 GeV respectively." The masses measured at CERN were 82 and 93 GeV, a brilliant confirmation of the electroweak unification.

The experiments at CERN detected a total of 10 W bosons and 4 Z bosons. In the extended experiment at Fermilab's [Tevatron](#) known as "Run 1" (1992–96), the [D0 detector facility](#) measured over 100,000 W particles. The D0 value for the mass of the W is 80.482 ± 0.091 GeV. Current values combining the experiments at the Tevatron and at CERN's LEP electron-positron collider are $M_W = 80.41 \pm 0.18$ GeV and $M_Z = 91.1884 \pm 0.0022$ GeV.

W' and Z' Bosons

From Wikipedia, the [free encyclopedia](#)

W' and Z' bosons	
Composition	Elementary particle
Statistics	Bosonic
Interactions	Standard-Model Extension ^[1]
Status	Hypothetical
Mass	unknown
Decays into	similar to W and Z bosons
Electric charge	W' : $\pm 1 e$ Z' : $0 e$
Spin	1 ^[1]
Spin states	2

In [particle physics](#), **W' and Z' bosons** (or **W-prime and Z-prime bosons**) refer to hypothetical new [gauge bosons](#) that arise from extensions of the [electroweak symmetry](#) of the [Standard Model](#). They are named in analogy with the Standard Model [W and Z bosons](#).

Types of W' bosons^[edit]

W' bosons often arise in models with an extra [SU\(2\) gauge group](#). $SU(2) \times SU(2)$ is spontaneously broken to the [diagonal subgroup](#) $SU(2)_W$ which corresponds to the electroweak $SU(2)$. More generally, we might have n copies of $SU(2)$, which are then broken down to a diagonal $SU(2)_W$. This gives rise to $n-1$ W^{+} , W^{-} and Z' bosons.

Such models might arise from [quiver diagram](#), for example. In order for the W' bosons to couple to isospin,^[*which?*] the extra $SU(2)$ and the Standard Model $SU(2)$ must mix; one copy of $SU(2)$ must break around the [TeV](#) scale (to get W' bosons with a TeV mass) leaving a second $SU(2)$ for the Standard Model. This happens in [Little Higgs](#) models that contain more than one copy of $SU(2)$. Because the W' comes from the breaking of an $SU(2)$, it is generically

accompanied by a Z' boson of (almost) the same mass and with couplings related to the W' couplings.

Another model with W' bosons but without an additional $SU(2)$ factor is the so-called [331 model](#) with $\beta = \pm 1/\sqrt{3}$. The symmetry breaking chain

$$SU(3)_L \times U(1)_W \rightarrow SU(2)_W \times U(1)_Y$$

leads to a pair of W'^{\pm} bosons and three Z' bosons.

W' bosons also arise in [Kaluza–Klein](#) theories with $SU(2)$ in the [bulk](#).

Types of Z' bosons

Various models of physics [beyond the Standard Model](#) predict different kinds of Z' bosons.

- Models with a new [U\(1\)](#) gauge symmetry. The Z' is the gauge boson of the (broken) $U(1)$ symmetry.
- [E₆](#) models. This type of model contains two Z' bosons, which can mix in general.
- [Topcolor](#) and Top Seesaw Models of Dynamical Electroweak Symmetry Breaking have Z' bosons to select the formation of particular condensates.
- [Little Higgs](#) models. These models typically include an enlarged gauge sector, which is broken down to the Standard Model gauge symmetry around the TeV scale. In addition to one or more Z' bosons, these models often contain W' bosons.
- [Kaluza–Klein](#) models. The Z' bosons are the excited modes of a neutral bulk gauge symmetry.
- Stueckelberg Extensions (see [Stueckelberg action](#)). The Z' boson is sourced from couplings found in [string](#) theories with intersecting [D-branes](#).

Bosons in Vedic Physics

In Vedic Physics, bosons follow the rubric below:

Boson charge	Vedic Physics	RTA Flow	
W+	Rajo Guna	Above normal	Dynamic
W-	Tamo Guna	Below normal	Substratum
Z	Sato Guna	Normal	Stable matter

These particles are known in Vedic Physics as Vartmas, and the three types are known as Trivartmas. However, Trivartmas differ from Bosons in some ways and future papers on Vixra by this author will attempt to convey those differences. Primarily, Trivartmas carry a spin=1, and the RTA may move in forward or reverse directions. All three are related to the form of seven hyper-circles, in the author's terminology, which may be related to the Octonions.

For those who have been following the author's work on Vixra, the three types above conform to the three types of matter in the Universe, discussed in earlier papers. Thus we may confirm the work of both authors of Vedic Physics books as supporting each other's work - they do not create a contradiction.

Readers of literature and philosophy will find these three types in many places with different connotations, but in works about physics, references are made to distinguish the three types of matter.

Conclusion

Division of bosons into three major types should help to create an accurate typology of bosons, as well as clarify their functions in the different realms of matter. This paper provides a major clue to western particle physicists as to the nature of matter and they would do well to heed this hint and derive the most benefit from this clue.

An immediate application might be to gauge bosons, and so the Wikipedia entry for such has been included within this paper.

Raja is related to dynamic matter, the 9 x 9 form identified with the Tai Xuan Jing, the Dao De Jing and one section of the Yellow Emperor's Internal Medicine Classic (Huang Di Nei Jing) of Chinese metaphysics and medicine.

Satwa refers to the stable 8 x 8 form of matter ascribed to the I Ching and the Eight Trigrams of Chinese metaphysics, as well as all of its offshoots, such as Qi Men Dun Jia and Da Liu Ren. Recall as well that the 64 hexagrams of the I Ching form an isomorphic relationship to the 64 amino acids of the DNA double helix, as discovered by Jungian analyst Marie - Louise von Franz in 1970.

Finally, Thamic refers to the invisible "Dark Matter" of the Substratum, which the author has described in previous papers on Vixra. Therefore, one may logically conclude that gauge bosons of negative charge are intrinsically related to what western science now regards as black holes and dark matter.

With luck, this start of a bosonic typology should begin to lead particle physicists in the right direction. Ultimately, through continued application of the principles of Vedic Physics, the author hopes to achieve an amalgam of contemporary and Vedic Physics that points modern science towards the proper direction for future research.

Appendix

The theory of the [weak nuclear force](#) developed by [Steven Weinberg](#) and [Abdus Salam](#) predicted that apart from the [W particles](#) that mediated [quark](#) flavor changes and resulted in [beta decay](#), there is another type of [intermediate vector boson](#) associated with the weak force, the Z particle, which causes the so-called "[neutral current](#)" processes (so named because the Z particle is electrically neutral), that generally involve the ghostly particles known as [neutrinos](#).

These phenomena were first observed at [CERN](#) in 1973, and gave much-needed experimental proof of the new Weinberg-Salam theory of the weak force. The actual Z particle which mediated these neutral current phenomena were observed a decade later by [Simon van der Meer](#) and [Carlo Rubbia](#), also at CERN.

An example of a neutral current event what happens when a neutrino or some other similar particle is scattered on an atomic nucleus. Because the Z particle that causes this interaction is very, very heavy ($91 \text{ GeV}/c^2$, or about the mass of a [zirconium](#) atom), the distance at which the neutrino must approach the atomic nucleus for a neutral current reaction to occur must be correspondingly short, less than \hbar/m_Zc , $1.4 \times 10^{-17} \text{ m}$ (smaller than the size of a [proton](#)!), i.e. the neutrino must hit the target nucleus very nearly head-on.

This means that the chances of this event happening are extremely small, even with very high-energy neutrinos, but these chances are not zero. Very occasionally one of the neutrinos will actually hit an atomic nucleus head-on, emitting a Z particle which is absorbed by the nucleus, which breaks apart as a result. The neutrino loses energy, but is otherwise unchanged.

One experiment at [Fermilab](#) involved using a particle detector that consisted of 700 tons of steel and detection apparatus. One in a billion neutrinos generated by the [Tevatron](#) managed to collide with the iron nuclei in the steel, breaking it apart.

The neutral current processes mediated by the Z particle also provided the final evidence of [neutrino oscillations](#) and served to close the [solar neutrino problem](#). The [Sudbury Neutrino Observatory](#) (SNO) used [heavy water](#) and watched for neutral current reactions with solar neutrinos that broke apart the [deuterium](#) nuclei in the heavy water. Unlike earlier neutrino observatories like the [Super Kamiokande](#), which used [inverse beta](#)

[decay](#) (charged current reactions that involve the W particles) to find neutrinos, neutral current reactions in the SNO should occur regardless of the type of neutrino.

The older detectors would have detected only [electron neutrinos](#), so if neutrino oscillations were occurring that changed the types of neutrinos (transforming an electron neutrino generated by a [nuclear fusion](#) reaction in the sun into a [muon neutrino](#) for instance), they would see only a fraction of the sun's predicted neutrino flux. The observations of neutral current events at the SNO gave results that agreed closely with theories of the sun's neutrino output, providing persuasive proof of neutrino oscillations.

As previously noted, the Z particle has no electric charge, and does not possess any other distinguishing property, so it is also its own [antiparticle](#) (as with the photon and other uncharged [field bosons](#)). Like its partner the W particle, it also has [spin 1](#), as the weak force is a [vector field](#). It has a mass of $91 \text{ GeV}/c^2$, and decays very rapidly into a quark and its matching antiquark (producing [hadron jets](#) or sometimes [mesons](#)), or a [lepton](#) and its corresponding anti-lepton, depending on how much energy the particle has.

Sources:

<http://www2.slac.stanford.edu/vvc/theory/weakinteract.html>

<http://www2.slac.stanford.edu/vvc/theory/weakbosons.html>

<http://www.fnal.gov/pub/ferminews/Ferminews01-11-09.pdf>

<http://www.physics.carleton.ca/research/sno/results/rates.html>

<http://news.bbc.co.uk/1/hi/sci/tech/1943837.stm>

Bibliography

<http://www.everything2.com/index.pl?node=Z%20particle>

<http://hyperphysics.phy-astr.gsu.edu/hbase/particles/expar.html#c4>

Vedic Particle Physics (Beyond Quarks) : The System of Nuclear Growth and Life Grown up from the Sad-brahma as in Rg Veda : Khem Chand Sharma, p. 139.

Contact

The author may be contacted at jaq2013 at outlook dot com



"There are those who look at things the way they are, and ask why... I dream of things that never were, and ask why not?"

Let's dedicate ourselves to what the Greeks wrote so many years ago: **to tame the savageness of man and make gentle the life of this world.**

Robert Francis Kennedy