

Gravitational Wave Experiments with Zener Diode Quantum Detectors: Fractal Dynamical Space

Reginald T. Cahill

*School of Chemical and Physical Sciences, Flinders University, Adelaide 5001, Australia
Progress in Physics, 10 (3), 131-138, 2014*

The discovery that the electron current fluctuations through Zener diode pn junctions in reverse bias mode, which arise via quantum barrier tunnelling, are completely driven by space fluctuations, has revolutionised the detection and characterisation of gravitational waves, which are space fluctuations, and also has revolutionised the interpretation of probabilities in the quantum theory. Here we report very simple and cheap table-top gravitational wave experiments using Zener diode detectors, and reveal the implications for the nature of space and time, and for the quantum theory of “matter”, and the emergence of the “classical world” as space-induced wave function localisation. The dynamical space poses an intrinsic inflation epoch.

1 Introduction

Physics, from the earliest days, has missed the existence of space as a dynamical and structured process, and instead took the path of assuming space to be a geometrical entity. This failure was reinforced by the supposed failure of the earliest experiment designed to detect such structure by means of light speed anisotropy: the 1887 Michelson-Morley experiment. Based upon this so-called “null” experiment the geometrical modelling of space was extended to the spacetime geometrical model. However in 2002 [1, 2] it was discovered that this experiment was never “null”: Michelson had assumed Newtonian physics in calibrating the interferometer, and a re-analysis of that calibration using neo-Lorentz relativity [3] revealed that the Newtonian calibration overestimated the sensitivity of the detector by nearly a factor of 2000, and the observational data actually indicated an anisotropy speed up to $\pm 550\text{km/s}$, depending of direction. The spacetime model of course required that there be no anisotropy [3]. The key result of the neo-Lorentz relativity analysis was the discovery that the Michelson interferometer had a design flaw that had gone unrecognised until 2002, namely that the detector had zero sensitivity to light speed anisotropy unless operated with a dielectric present in the light paths. Most of the more recent “confirmations” of the putative null effect employed versions of the Michelson interferometer in vacuum mode: vacuum resonant cavities, such as [4].

The experimental detections of light speed anisotropy, via a variety of experimental techniques over 125 years, shows that light speed anisotropy detections were always associated with significant turbulence/fluctuation wave effects [5,6]. Repeated experiments and observations are the hallmark of science. These techniques included: gas-mode Michelson interferometers, RF EM Speeds in Coaxial Cable, Optical Fiber Michelson Interferometer, Optical Fiber / RF Coaxial Cables,

Earth Spacecraft Flyby RF Doppler Shifts and 1st Order Dual RF Coaxial Cables. These all use classical phenomena.

However in 2013 the first direct detection of space was made possible by the discovery of the Nanotechnology Zener Diode Quantum Detector effect [7]. This uses wave-form correlations between electron barrier quantum tunnelling current fluctuations in spatially separated reverse-biased Zener diodes: gravitational waves. The 1st experiments discovered this effect in correlations between detectors in Australia and the UK, which revealed the average anisotropy vector to be 512km/s , $RA=5.3\text{hrs}$, $Dec=81^\circ$ (direction of Earth through space) on January 1, 2013, in excellent agreement with earlier experiments, particularly the Spacecraft Earth-Flyby RF Doppler Shifts, [8].

Here we elaborate the very simple and cheap table-top gravitational wave experiments using Zener diode detectors, and reveal the implications for the nature of space and time, and for the quantum theory of “matter”, and the emergence of the “classical world” as space-induced wave function localisation. This reveals the emerging physics of a unified theory of space, gravity and the quantum, [9].

2 Quantum Gravitational Wave Detectors

The Zener diode quantum detector for gravitational waves is shown in Fig.1. Experiments reveal that the electron current fluctuations are solely caused by space fluctuations [7]. Fig.5, top, shows the highly correlated currents of two almost collocated Zener diodes. The usual interpretations of quantum theory, see below, claim that these current fluctuations should be completely random, and so uncorrelated, with the randomness intrinsic to each diode. Hence the Zener diode experiments falsifies that claim. With these correlations the detector

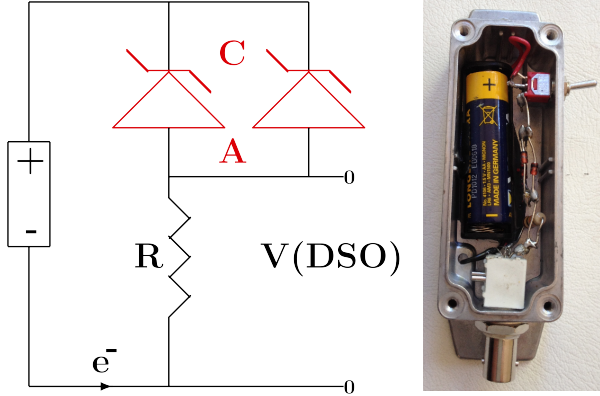

Fig. 1: Left: Circuit of Zener Diode Gravitational Wave Detector, showing 1.5V AA battery, two 1N4728A zener diodes operating in reverse bias mode, and having a Zener voltage of 3.3V, and resistor $R = 10K\Omega$. Voltage V across resistor is measured and used to determine the space driven fluctuating tunnelling current through the zener diodes. Correlated currents from two collocated detectors are shown in Fig.5. Right: Photo of detector with 5 Zener diodes in parallel. Increasing the number of diodes increases the S/N ratio, as the V measuring device will produce some noise. Doing so demonstrates that collocated diodes produce in-phase current fluctuations, as shown in Fig.5, top, contrary to the usual interpretation of probabilities in quantum theory.

S/N ratio is then easily increase by using diodes in parallel, as shown in Fig.1. The source of the “noise” is, in part, space induced fluctuations in the DSO that measures the very small voltages. When the two detectors are separated by 25cm, and with the detector axis aligned with the South Celestial Pole, as shown in Fig.4, the resulting current fluctuations are shown in Fig.5, bottom, revealing that the N detector current fluctuations are delayed by $\sim 0.5\mu s$ relative to the S detector.

The travel time delay $\tau(t)$ was determined by computing the correlation function between the two detector voltages

$$C(\tau, t) = \int_{t-T}^{t+T} dt' S_1(t' - \tau/2) S_2(t' + \tau/2) e^{-a(t'-t)^2} \quad (1)$$

The fluctuations in Fig.5 show considerable structure at the μs time scale (higher frequencies have been filtered out by the DSO). Such fluctuations are seen at all time scales, see [10], and suggest that the passing space has a fractal structure, illustrated in Fig.7. The measurement of the speed of passing space is now elegantly and simply measured by this very simple and cheap table-top experiment. As discussed below those fluctuations in velocity are gravitational waves, but not with the characteristics usually assumed, and not detected despite enormous effects. At very low frequencies the data from Zener diode detectors and from resonant bar detectors reveal sharp resonant frequencies known from seismology to be the same as the Earth vibration frequencies [11–13]. We shall

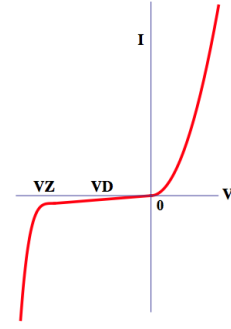

Fig. 2: Current-Voltage (IV) characteristics for a Zener Diode. $VZ = -3.3V$ is the Zener voltage, and $VD \approx -1.5V$ is the operating voltage for the diode in Fig.1. $V > 0$ is the forward bias region, and $V < 0$ is the reverse bias region. The current near VD is very small and occurs only because of wave function quantum tunnelling through the potential barrier, as shown in Fig.3.

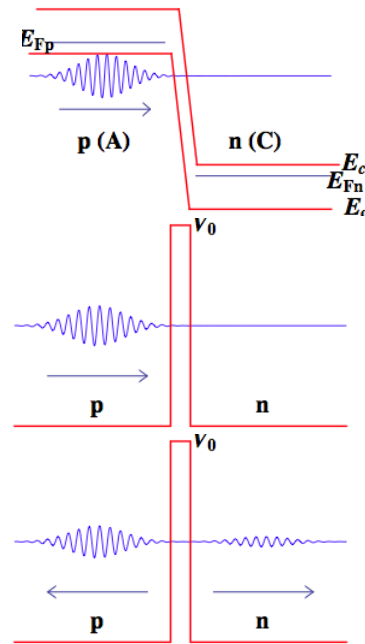

Fig. 3: Top: Electron before tunnelling, in reverse biased Zener diode, from valence band in doped p semiconductor, with hole states available, to conduction band of doped n semiconductor. A and C refer to anode and cathode labelling in Fig.1. E_c is bottom of conduction bands, and E_v is top of valence bands. E_{Fp} and E_{Fn} are Fermi levels. There are no states available in the depletion region. Middle: Schematic for electron wave packet incident on idealised effective interband barrier in a pn junction, with electrons tunnelling A to C , appropriate to reverse bias operation. Bottom: Reflected and transmitted wave packets after interaction with barrier. Energy of wave packet is less than potential barrier height V_0 . The wave function transmission fluctuations and collapse to one side or the other after barrier tunnelling is now experimentally demonstrated to be caused by passing space fluctuations.

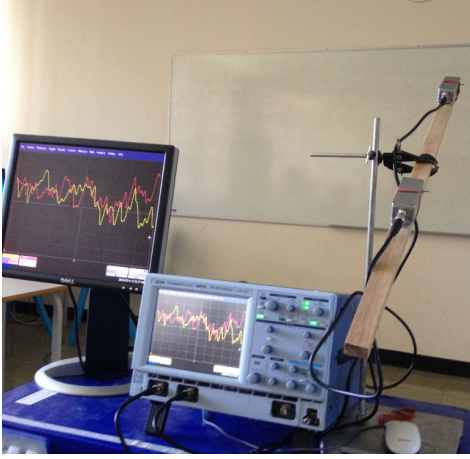

Fig. 4: Zener diode gravitational wave detector, showing the two detectors orientated towards south celestial pole, with a separation of 50cm. The data reported herein used a 25cm separation. The DSO is a LeCroy Waverunner 6000A. The monitor is for lecture demonstrations of gravitational wave measurements of speed and direction, from time delay of waveforms from S to N detectors.

now explore the implications for quantum and space theories.

3 Zener Diodes Detect Dynamical Space

The generalised Schrödinger equation [14]

$$i\hbar \frac{\partial \psi(\mathbf{r}, t)}{\partial t} = -\frac{\hbar^2}{2m} \nabla^2 \psi(\mathbf{r}, t) + V(\mathbf{r})\psi(\mathbf{r}, t) - i\hbar \left(\mathbf{v}(\mathbf{r}, t) \cdot \nabla + \frac{1}{2} \nabla \cdot \mathbf{v}(\mathbf{r}, t) \right) \psi(\mathbf{r}, t) \quad (2)$$

models “quantum matter” as a purely wave phenomenon. Here $\mathbf{v}(\mathbf{r}, t)$ is the velocity field describing the dynamical space at a classical field level, and the coordinates \mathbf{r} give the relative location of $\psi(\mathbf{r}, t)$ and $\mathbf{v}(\mathbf{r}, t)$, relative to a Euclidean embedding space, also used by an observer to locate structures. At a sufficiently small distance scales that embedding and the velocity description is conjectured to be not possible, as then the dynamical space requires an indeterminate dimension embedding space, being possibly a quantum foam, [9]. This minimal generalisation of the original Schrödinger equation arises from the replacement $\partial/\partial t \rightarrow \partial/\partial t + \mathbf{v} \cdot \nabla$, which ensures that the quantum system properties are determined by the dynamical space, and not by the embedding coordinate system, which is arbitrary. The same replacement is also to be implemented in the original Maxwell equations, yielding that the speed of light is constant only wrt the local dynamical space, and which results in lensing from stars and black holes. The extra $\nabla \cdot \mathbf{v}$ term in (2) is required to make the hamiltonian in (2) hermitian. Essentially the existence of the dynamical space in all theories has been missing. The dynamical theory of space itself is briefly reviewed below.

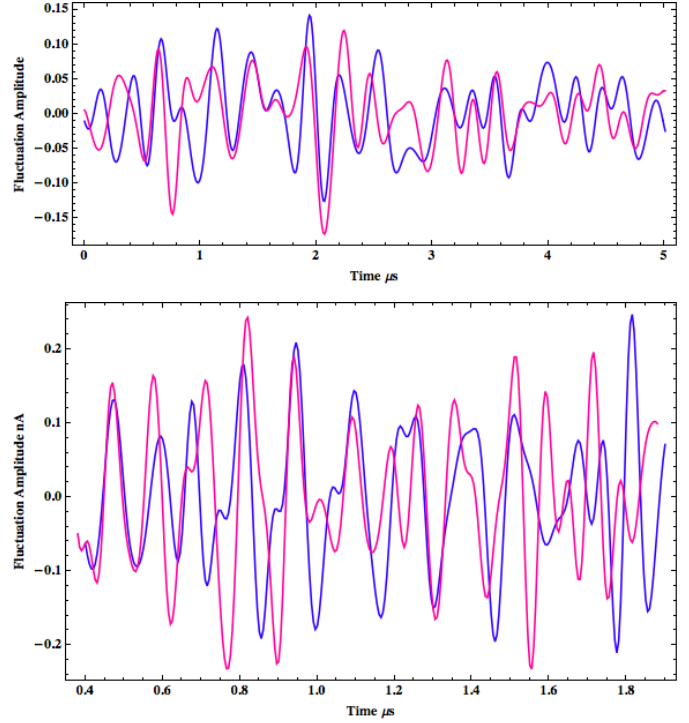

Fig. 5: Top: Current fluctuations from two collocated Zener diode detectors, as shown in Fig.1, separated by 3-4 cm in EW direction due to box size, revealing strong correlations. The small separation may explain slight differences, revealing a structure to space at very small distances. Bottom: Example of Zener diode current fluctuations (nA), about a mean of $\sim 3.5 \mu\text{A}$, when detectors separated by 25cm, and aligned in direction RA=5hrs, Dec=-80°, with southerly detector signal delayed in DSO by 0.48 μs , and then showing strong correlations with northerly detector signal. This time delay effect reveals space traveling from S to N at a speed of approximately 476km/s, from maximum of correlation function $C(\tau, t)$, with time delay τ expressed as a speed. Data has been smoothed by FFT filtering to remove high and low frequency components. Fig.6, top, shows fluctuations in measured speed over a 15 sec interval.

A significant effect follows from (2), namely the emergence of gravity as a quantum effect: a wave packet analysis shows that the acceleration of the wave packet, due to the space terms alone (when $V(\mathbf{r}) = 0$), is given by $\mathbf{g} = d^2 \langle \mathbf{r} \rangle / dt^2$, [14],

$$\mathbf{g}(\mathbf{r}, t) = \frac{\partial \mathbf{v}}{\partial t} + (\mathbf{v} \cdot \nabla) \mathbf{v} \quad (3)$$

That derivation showed that the acceleration is independent of the mass m : whence we have the 1st derivation of the Weak Equivalence Principle, discovered by Galileo. The necessary coupling of quantum systems to the fractal dynamical space implies the generation of masses, as now the waves are not propagating through a structureless Euclidean geometrical space: this may provide a dynamical mechanism for the Higgs phenomenology.

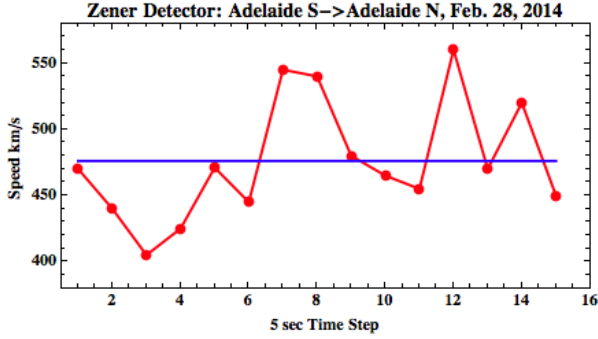

Fig. 6: Average projected speed, and projected speed every 5 sec, on February 28, 2014 at 12:20 hrs UTC, giving average speed = 476 ± 44 (RMS) km/s, from approximately S \rightarrow N. The speeds are effective projected speeds, and so do not distinguish between actual speed and direction effect changes. The projected speed = (actual speed)/ $\cos[a]$, where a is the angle between the space velocity and the direction defined by the two detectors, and cannot be immediately determined with only two detectors. However by varying direction of detector axis, and searching for maximum time delay, the average direction (RA and Dec) may be determined. As in previous experiments there are considerable fluctuations at all time scales, indicating a fractal structure to space.

4 Quantum Tunnelling Fluctuations and Dynamical Space

It is possible to understand the space driven Zener diode reverse-bias-mode current fluctuations. The operating voltage and energy levels for the electrons at the pn junction are shown schematically in Figs.2 and 3. For simplicity consider wave packet solutions to (2) applicable to the situation in Fig.3, using a complete set of plane waves,

$$\psi(\mathbf{r}, t) = \int d^3\mathbf{k} d\omega \psi(\mathbf{k}, \omega) e^{i\mathbf{k}\cdot\mathbf{r} - i\omega t} \quad (4)$$

Then the space term contributes the term $\hbar\mathbf{v} \cdot \mathbf{k}$ to the equations for $\psi(\mathbf{k}, \omega)$, assuming we can approximate $\mathbf{v}(\mathbf{r}, t)$ by a constant over a short distance and interval of time. Here \mathbf{k} are wave numbers appropriate to the electrons. However the same analysis should also be applied to the diode, considered as a single massive quantum system, giving an energy shift $\hbar\mathbf{v} \cdot \mathbf{K}$, where \mathbf{K} is the much larger wavenumber for the diode. Effectively then the major effect of space is that the barrier potential energy is shifted: $V_0 \rightarrow V_0 + \hbar\mathbf{v} \cdot \mathbf{K}$. This then changes the barrier quantum tunnelling amplitude, $T(V_0 - E) \rightarrow T(V_0 + \hbar\mathbf{v} \cdot \mathbf{K} - E)$, where E is the approximate energy of the electron, and this amplitude will then be very sensitive to fluctuations in \mathbf{v} .

Quantum theory accurately predicts the transition amplitude $T(V_0 - E)$, with $|T|^2$ giving the average electron current, where i is the incident current at the pn junction. However quantum theory contains no randomness or probabili-

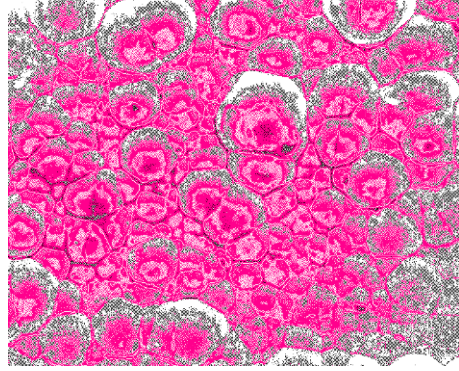

Fig. 7: Representation of the fractal wave data as revealing the fractal textured structure of the 3-space, with cells of space having slightly different velocities and continually changing, and moving wrt the Earth with a speed of ~ 500 km/s.

ties, the original Schrödinger equation is purely deterministic: probabilities arise solely from *ad hoc* interpretations, and these assert that the actual current fluctuations are purely random, and intrinsic to each quantum system, here each diode. However the experimental data shows that these current fluctuations are completely determined by the fluctuations in the passing space, as demonstrated by the time delay effect, herein at the μs time scale and in [7] at the 10-20sec scale. Hence the Zener diode effect represents a major discovery re the so called interpretations of quantum theory.

5 Alpha Decay Rate Fluctuations

Shnoll [15] discovered that the α decay rate of ^{239}Pu is not completely random, as it has discrete preferred values. The same effect is seen in the histogram analysis of Zener diode tunnelling rates, [17]. This α decay process is another example of quantum tunnelling: here the tunnelling of the α wave packet through the potential energy barrier arising from the Coulomb repulsion between the α “particle” and the residual nucleus, as first explained by Gamow in 1928, [16]. The analysis above for the Zener diode also applies to this decay process: the major effect is the changing energy of the alpha particle produced by space velocity fluctuations, which alter the barrier tunnelling rate. Shnoll also reported correlations between decay rate fluctuations measured at different locations. However the time resolution was $>60\text{sec}$, and so no speed and direction for the underlying space velocity was determined. It is predicted that α decay fluctuation rates with a time resolution of ~ 1 sec would show the time delay effect for experiments well separated geographically.

6 Reinterpretation of Quantum Theory

The experimental data herein clearly implies a need for a reinterpretation of quantum theory, as it has always lacked the dynamical effects of the fractal space: it only ever referred to the Euclidean static embedding space, which merely provides a position labelling. However the interpretation of the quantum theory has always been problematic and varied. The main problem is that the original Schrödinger equation does not describe the localisation of quantum matter when measured, e.g. the formation of spots on photographic films. From the beginning of quantum theory a metaphysical addendum was created, as in the Born interpretation, namely that there exists an almost point-like “particle”, and that $|\psi(\mathbf{r}, t)|^2$ gives the probability density for the location of that particle, whether or not a measurement of position has taken place. This is a dualistic interpretation of the quantum theory: there exists a “wave function” as well as a “particle”, and that the probability of a detection event is completely internal to a particular quantum system. So there should be no correlations between detection events for different systems, contrary to the experiments reported here. To see the failure of the Born and other interpretations consider the situation shown in Fig.3. In the top figure the electron state is a wave packet $\psi_1(\mathbf{r}, t)$, partially localised to the left of a potential barrier. After the barrier tunnelling the wave function has evolved to the superposition $\psi_2(\mathbf{r}, t) + \psi_3(\mathbf{r}, t)$: a reflected and transmitted component. The probability of the electron being detected to the LHS is $\|\psi_2(\mathbf{r}, t)\|^2$, and to the RHS is $\|\psi_3(\mathbf{r}, t)\|^2$, the respective squared norms. These values do indeed predict the observed average reflected and transmitted electron currents, but makes no prediction about the fluctuations that lead to these observed averages. As well, in the Born interpretation, there is no mention of a collapse of the wave function, to one of the states in the linear combination, as the single location is in the metaphysics of the interpretation, and not in any physical process.

There is another process whose explanation has also never been satisfactorily explained, namely that when a quantum system, such as an electron or photon in a de-localised state, interacts with a detector, i.e. a system in a metastable state, the electron would put the combined system into a de-localised state, which is then observed to localise: the detector responds with an event at one location, but for which the quantum theory can only provide the expected average distribution, $|\psi(\mathbf{r}, t)|^2$, and is unable to predict fluctuation details. In [9] it was conjectured that the delocalised electron-detector state is localised by the interaction with the dynamical space, and that the fluctuation details are produced by the space fluctuations, as we see in Zener diode electron tunnelling and α decay tunnelling. Percival [18] has produced detailed models of this wave function collapse process, which involved an intrinsic randomness, and which involves yet another dynamical term being added to the original Schrödinger equation. It

is possible that this randomness may also be the consequence of space fluctuations.

The space driven localisation of quantum states could give rise to our experienced classical world, in which macroscopic “matter” is not seen in de-localised states. It was the inability to explain this localisation process that gave rise to the Copenhagen and numerous other interpretations of the original quantum theory, and in particular the dualistic model of wave functions and almost point-like localised “particles”.

7 Dynamical 3-Space

If Michelson and Morley had more carefully presented their pioneering data physics would have developed in a very different direction. Even by 1925/26 Miller, a junior colleague of Michelson, was repeating the gas-mode interferometer experiment, and by not using Newtonian mechanics to attempt a calibration of the device, rather by using the Earth aberration effect which utilised the Earth orbital speed of 30km/s to set the calibration constant, although that also entailed false assumptions. The experimental data reveals the existence of a dynamical space. It is a simple matter to arrive at the dynamical theory of space, and the emergence of gravity as a quantum matter effect as noted above. The key insight is to note that the emergent matter acceleration in (3), $\partial\mathbf{v}/\partial t + (\mathbf{v}\cdot\nabla)\mathbf{v}$, is the constituent Euler acceleration $\mathbf{a}(\mathbf{r}, t)$ of space

$$\begin{aligned}\mathbf{a} &= \lim_{\Delta t \rightarrow 0} \frac{\mathbf{v}(\mathbf{r} + \mathbf{v}(\mathbf{r}, t)\Delta t, t + \Delta t) - \mathbf{v}(\mathbf{r}, t)}{\Delta t} \\ &= \frac{\partial\mathbf{v}}{\partial t} + (\mathbf{v}\cdot\nabla)\mathbf{v}\end{aligned}$$

which describes the acceleration of a constituent element of space by tracking its change in velocity. This means that space has a structure that permits its velocity to be defined and detected, which experimentally has been done. This then suggests that the simplest dynamical equation for $\mathbf{v}(\mathbf{r}, t)$ is

$$\nabla \cdot \left(\frac{\partial\mathbf{v}}{\partial t} + (\mathbf{v}\cdot\nabla)\mathbf{v} \right) = -4\pi G\rho(\mathbf{r}, t); \quad \nabla \times \mathbf{v} = \mathbf{0}$$

because it then gives $\nabla \cdot \mathbf{g} = -4\pi G\rho(\mathbf{r}, t)$; $\nabla \times \mathbf{g} = \mathbf{0}$, which is Newton’s inverse square law of gravity in differential form. Hence the fundamental insight is that Newton’s gravitational acceleration field $\mathbf{g}(\mathbf{r}, t)$ is really the acceleration field $\mathbf{a}(\mathbf{r}, t)$ of the structured dynamical space*, and that quantum matter acquires that acceleration because it is fundamentally a wave effect, and the wave is refracted by the accelerations of space.

Note that even a time independent matter density, or even in the absence of matter, there can be a time-dependent flow, but then with a time-independent \mathbf{g} . In particular this dynamical space in the absence of matter has an expanding universe

*With vorticity $\nabla \times \mathbf{v} \neq \mathbf{0}$ and relativistic effects, the acceleration of matter becomes different from the acceleration of space [9].

solution. Substituting the Hubble form $\mathbf{v}(\mathbf{r}, t) = H(t)\mathbf{r}$, and then using $H(t) = \dot{a}(t)/a(t)$, where $a(t)$ is the scale factor of the universe, we obtain the exact solution $a(t) = t/t_0$, where t_0 is the age of the universe, since by convention $a(t_0) = 1$. Then computing the magnitude-redshift function $\mu(z)$, we obtain excellent agreement with the supernova data, and without the need for ‘dark matter’ nor ‘dark energy’, [19]. Using the extended dynamics in (5) we obtain $a(t) = (t/t_0)^{1/(1+5\alpha/2)}$, which has a singularity at $t = 0$, giving rise to an inflationary epoch.

While the above lead to the simplest 3-space dynamical equation this derivation is not complete yet. One can add additional terms with the same order in speed spatial derivatives, and which cannot be *a priori* neglected. There are two such terms, as in

$$\nabla \cdot \left(\frac{\partial \mathbf{v}}{\partial t} + (\mathbf{v} \cdot \nabla) \mathbf{v} \right) + \frac{5\alpha}{4} ((trD)^2 - tr(D^2)) + \dots = -4\pi G\rho$$

where $D_{ij} = \partial v_i / \partial x_j$. However to preserve the inverse square law external to a sphere of matter the two terms must have coefficients α and $-\alpha$, as shown. Here α is a dimensionless space self-interaction coupling constant, which experimental data reveals to be, approximately, the fine structure constant, $\alpha = e^2/\hbar c$, [20]. The ellipsis denotes higher order derivative terms with dimensioned coupling constants, which come into play when the flow speed changes rapidly wrt distance. The observed dynamics of stars and gas clouds near the centre of the Milky Way galaxy has revealed the need for such a term [21], and we find that the space dynamics then requires an extra term

$$\nabla \cdot \left(\frac{\partial \mathbf{v}}{\partial t} + (\mathbf{v} \cdot \nabla) \mathbf{v} \right) + \frac{5\alpha}{4} ((trD)^2 - tr(D^2)) + \delta^2 \nabla^2 ((trD)^2 - tr(D^2)) + \dots = -4\pi G\rho \quad (5)$$

where δ has the dimensions of length, and appears to be a very small Planck-like length, [21]. This then gives us the dynamical theory of 3-space. It can be thought of as arising via a derivative expansion from a deeper theory, such as a quantum foam theory, [9]. Note that the equation does not involve c , is non-linear and time-dependent, and involves non-local direct interactions. Its success implies that the universe is more connected than previously thought. Even in the absence of matter there can be time-dependent flows of space.

Note that the dynamical space equation, apart from the short distance effect - the δ term, there is no scale factor, and hence a scale free structure to space is to be expected, namely a fractal space. That dynamical equation has back hole and cosmic filament solutions [20,21], which are non-singular because of the effect of the δ term. At large scales it appears that a homogeneous space is dynamically unstable and undergoes dynamical breakdown of symmetry to form a spatial network of black holes and filaments, [20], to which matter is attracted and coalesces into gas clouds, stars and galaxies.

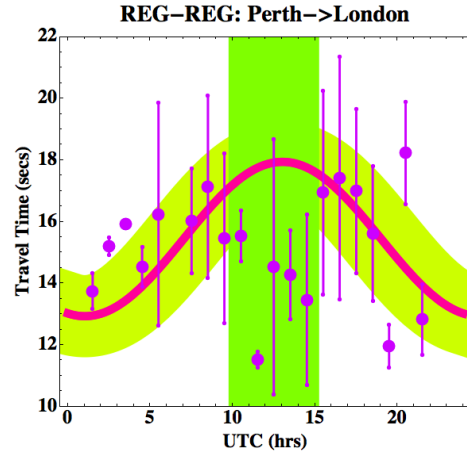

Fig. 8: Travel times from Zener Diode detectors (REG-REG) Perth-London from correlation delay time analysis, from [7]. The data in each 1 hr interval has been binned, and the average and rms shown. The thick (red line) shows best fit to data using plane wave travel time predictor, see [7], but after excluding those data points between 10 and 15hrs UTC, indicated by vertical band. Those data points are not consistent with the plane wave modelling, and suggest a scattering process when the waves pass deeper into the Earth, see [7]. This Perth-London data gives speed = 528 km/s, RA = 5.3 hrs, Dec = 81°S. The broad band tracking the best fit line is for +/- 1 sec fluctuations, corresponding to speed fluctuation of +/- 17km/s. Actual fluctuations are larger than this, as 1st observed by Michelson-Morley in 1887 and by Miller in 1925/26.

We can write (5) in non-linear integral-differential form

$$\frac{\partial u}{\partial t} = -\frac{(\nabla u)^2}{2} + G \int d^3 r' \frac{\rho(\mathbf{r}', t) + \rho_{DM}(\mathbf{v}(\mathbf{r}', t))}{|\mathbf{r} - \mathbf{r}'|} \quad (6)$$

on satisfying $\nabla \times \mathbf{v} = \mathbf{0}$ by writing $\mathbf{v} = \nabla u$. Effects on the Gravity Probe B (GPB) gyroscope precessions caused by a non-zero vorticity were considered in [23]. Here ρ_{DM} is an effective ‘‘dark density’’ induced by the 3-space dynamics, but which is not any form of actual matter,

$$\rho_{DM}(\mathbf{v}(\mathbf{r}, t)) = \frac{1}{4\pi G} \left(\frac{5\alpha}{4} ((trD)^2 - tr(D^2)) + \delta^2 \nabla^2 ((trD)^2 - tr(D^2)) \right) \quad (7)$$

8 Earth Scattering Effect

In [7] correlated waveforms from Zener diode detectors* in Perth and London were used to determine the speed and di-

*These are known as REGs (Random Event Generators, and are commercially sold as such), and were used in the GCP network. However the outputs, as shown in [7], are not random. GCP data is available from <http://teihard.global-mind.org/>. This data extends back some 15 years and represents an invaluable resource for the study of gravitational waves, and their various effects, such as solar flares, coronal mass ejections, Earthquakes, eclipse effects, moon phase effects, non-Poisson fluctuations in radioactivity [15], and variations in radioactive decay rates related to distance of the Earth from the Sun [22], as the 3-space fluctuations are enhanced by proximity to the sun.

rection of gravitational waves, and detected an Earth scattering effect: the effective speed is larger when the 3-space path passes deeper into the Earth, Fig.8. Eqn.(6) displays two kinds of waveform effects: disturbances from the 1st part, $\partial u/\partial t = -(\nabla u)^2/2$; and then matter density and the “dark matter” density effects when the 2nd term is included. These later effects are instantaneous, indicating in this theory, that the universe (space) is highly non-locally connected, see [9], and combine in a non-linear manner with local disturbances that propagate at the speed of space. The matter density term is of course responsive for conventional Newtonian gravity theory. However because these terms cross modulate the “dark matter” density space turbulence can manifest, in part, as a speed-up effect, as in the data in Fig.8. Hence it is conjectured that the Earth scattering effect manifest in the data affords a means to study the dynamics arising from (7). That dynamics has already been confirmed in the non-singular space inflow black holes and the non-singular cosmic filaments effects, which are exact analytic solutions to (5) or (6). Indeed by using data from suitably located Zener diode detectors, for which the detected space flow passes through the centre of the Earth, we could be able to study the black hole located there, i.e. to perform black hole scattering experiments.

9 Conclusions

We have reported the direct quantum detection of gravitational waves, using electron current fluctuations in reverse bias mode Zener diodes, separated by 25cm, that permitted the absolute determination of the 3-space velocity of some 500km/s, in agreement with the speed and direction from a number of previous analyses that involved light speed anisotropy, including in particular the NASA spacecraft Earth-flyby Doppler shift effect, and the 1st such Zener diode direct detections of space flow using correlations between Perth and London detectors in 2013. The experimental results reveal the nature of the dominant gravitational wave effects; they are caused by turbulence/fluctuations in the passing dynamical space, a space missing from physics theories, until its recent discovery. Quantum tunnelling fluctuations have been shown to be non-random, in the sense that they are completely induced by fluctuations in the passing space. It is also suggested that the localisation of massive quantum systems is caused by fluctuations in space, and so generating our classical world of localised objects, but which are essentially wave phenomena at the microlevel. There is then no need to invoke any of the usual interpretations of the quantum theory, all of which failed to take account of the existence of the dynamical space. Present day physics employs an embedding space, whose sole function is to label positions in the dynamical space. This [3]-dimensional embedding in a geometrical space, while being non-dynamical, is nevertheless a property of the dynamical

space at some scales. However the dynamical space at very small scales is conjectured not to be embeddable in a [3]-geometry, as discussed in [9].

References

- [1] Cahill R.T. and Kitto K., Michelson-Morley Experiments Revisited, *Apeiron*, 10(2),104-117, 2003.
- [2] Cahill, R.T., The Michelson and Morley 1887 Experiment and the Discovery of Absolute Motion, *Progress in Physics*, 3, 25-29, 2005.
- [3] Cahill R.T., Dynamical 3-Space: Neo-Lorentz Relativity, *Physics International* 4(1), 60-72. doi:10.3844/pisp.2013.60.72 Published Online 4 (1) (<http://www.thescipub.com/pi.toc>)
- [4] Braxmaier C., Müller H., Pradl O., Mlynek J., Peters O., Tests of Relativity Using a Cryogenic Optical Resonator, *Phys. Rev. Lett.* , 88, 010401, 2001.
- [5] Cahill R.T., Discovery of Dynamical 3-Space: Theory, Experiments and Observations - A Review, *American Journal of Space Science*, doi:10.3844 /ajssp.2,013.77.93 Published Online 1(2) 2013 (<http://www.thescipub.com/ajss.toc>)
- [6] Cahill R.T., Review of Gravitational Wave Detections: Dynamical Space, to be published in *Physics International*, 2014.
- [7] Cahill R.T. Nanotechnology Quantum Detectors for Gravitational Waves: Adelaide to London Correlations Observed, *Progress in Physics*, 2013, v. 4, 57-62.
- [8] Cahill R.T., Combining NASA/JPL One-Way Optical-Fiber Light-Speed Data with Spacecraft Earth-Flyby Doppler-Shift Data to Characterise 3-Space Flow, *Progress in Physics*, v. 4, 50-64, 2009.
- [9] Cahill R.T., Process Physics: From Information Theory to Quantum Space and Matter, *Nova Science Pub., New York*, 2005.
- [10] Cahill R.T., Characterisation of Low Frequency Gravitational Waves from Dual RF Coaxial-Cable Detector: Fractal Textured Dynamical 3-Space, *Progress in Physics*, v. 3, 3-10, 2012.
- [11] Cahill R.T., Observed Gravitational Wave Effects: Amaldi 1980 Frascati-Rome Classical Bar Detectors, 2013 Perth-London Zener-Diode Quantum Detectors, Earth Oscillation Mode Frequencies, *Progress in Physics*, 2014, v.10(1), 21-24.
- [12] Amaldi E., Coccia E., Frasca S., Modena I., Rapagnani P., Ricci F., Pallottino G.V., Pizzella G., Bonifazi P., Cosmelli C., Giovanardi U., Iafolla V., Ugazio S., and Vannaroni G., Background of Gravitational-Wave Antennas of Possible Terrestrial Origin - I, *Il Nuovo Cimento*, 1981, v. 4C, N. 3, 295-308.

- [13] Amaldi E., Frasca S., Pallottino G.V., Pizzella G., Bonifazi P., Background of Gravitational-Wave Antennas of Possible Terrestrial Origin - II, *Il Nuovo Cimento*, 1981, v. 4C, N. 3, 309-323.
- [14] Cahill R.T., Dynamical Fractal 3-Space and the Generalised Schrödinger Equation: Equivalence Principle and Vorticity Effects, *Progress in Physics*, v.1, 27-34, 2006.
- [15] Shnoll S.E., Cosmophysical Factors in Stochastic Processes, *American Research Press, Rehoboth, New Mexico, USA*, 2012.
- [16] Gamow G., Zur Quantentheorie des Atomkernes, *Z. Physik* 51, 204, 1928.
- [17] Rothall D.P. and Cahill R.T., Dynamical 3-Space: Observing Gravitational Wave Fluctuations with Zener Diode Quantum Detector: the Shnoll Effect, *Progress in Physics*, 2014, v. 10(1), 16-18.
- [18] Percival I., Quantum State Diffusion, *Cambridge University Press*, 1998.
- [19] Cahill R.T. and Rothall D., Discovery of Uniformly Expanding Universe, *Progress in Physics*, 1, 63-68, 2012.
- [20] Rothall D.P. and Cahill R.T., Dynamical 3-Space: Black Holes in an Expanding Universe, *Progress in Physics*, 4, 25-31, 2013.
- [21] Cahill R.T. and Kerrigan D., Dynamical Space: Supermassive Black Holes and Cosmic Filaments, *Progress in Physics* 4, 79-82, 2011.
- [22] Jenkins J.H., Fischbach E., Buncher J.B., Gruenwald J.T., Krause, D.E. and Mattes J.J., Evidence for Correlations Between Nuclear Decay Rates and Earth-Sun Distance, *Astropart. Phys.* 32, 42, 2009.
- [23] Cahill R.T., Novel Gravity Probe B Frame Dragging Effect, *Progress in Physics*, v. 3(1), 30-33, 2005.