

Impulse Gauss Curvatures
2002 SSHE-MA Conference

Howard Iseri
Mansfield University

Abstract: In Riemannian (differential) geometry, the differences between Euclidean geometry, elliptic geometry, and hyperbolic geometry are understood in terms of curvature. I think Gauss and Riemann captured the essence of geometry in their studies of surfaces and manifolds, and their point of view is spectacularly illuminating. Unfortunately, curvature is highly non-trivial to work with. I will talk about a more accessible version of curvature that dates back to Descartes.

Curvature

The Gauss curvature K is a generalization to surfaces of the curvature κ for curves that is covered in calculus. The curvature for the graph of a function f is closely related to the concavity, and since f'' is the derivative of the slope of the tangent line, the concavity tells us how fast the slope is changing. In other words, it is a measure of how much the curve is curving. The concavity, however, tells us the rate of curvature relative to distances along the x -axis. Therefore, the relationship between concavity and the shape of the curve is distorted. This distortion is eliminated in the curvature by considering the rate at which the unit tangent vector changes direction relative to distances along the curve. Of course, with curvature comes the usually messy arclength parameter ds .

Somewhat surprising is the fact that curvature has a nice geometric interpretation. The curvature of a circle of radius r is $\kappa = 1/r$, and if the curvature at some point of a curve is κ , then a circle of radius $r = 1/\kappa$ will be the best fit circle at that point. For example, at the point $(0,0)$ on the graph of $f(x) = x^2$, the curvature is $\kappa = 2$, which is the same as the curvature for a circle of radius $r = 1/2$ (see Figure 1).

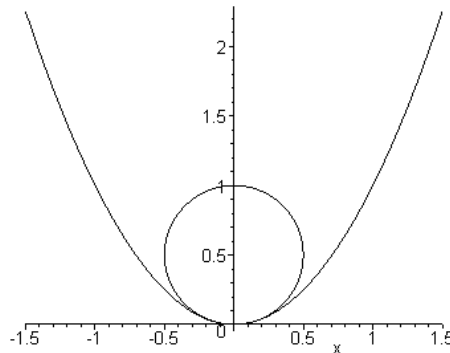

Figure 1. The curvature at $(0,0)$ is $\kappa = 2$ for both the circle and the parabola.

The Gauss curvature at a point on a surface (in \mathbf{R}^3) is the product of the maximum and minimum curvatures relative to a vector normal to the surface. Here, curvature "towards" the normal vector is positive, and curvature "away" is negative. For example, at the point $(0,0,0)$ on the surface $f(x,y) = x^2 - y^2$, there are both positive and negative curvatures relative to the normal vector $K = [0,0,1]$ (see Figure 2). Above the x -axis, we have a parabola with curvature $\kappa_{\max} = +2$ at $(0,0,0)$, and below the y -axis, we have a parabola with curvature κ_{\min}

= -2 at (0,0,0). The Gauss curvature at (0,0,0) is $K = (+2)(-2) = -4$. This surface would have a (non-homogeneous) hyperbolic geometry because of its negative curvature.

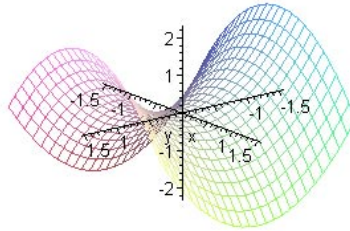

Figure 2. Saddle-shaped surfaces have negative Gauss curvature.

On the other hand, at the point (0,0,0) on the surface $f(x,y) = x^2 + y^2$, the curvatures are $\kappa_{\min} = \kappa_{\max} = +2$ in all directions. Therefore, the Gauss curvature is $K = (+2)(+2) = +4$ (see Figure 3). This surface would have a (non-homogeneous) elliptic geometry because of its positive curvature. Note that if the normal vector points downward, then $K = (-2)(-2) = +4$, so the choice of normal vector does not affect the value of K .

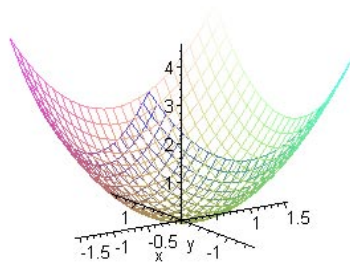

Figure 3. Bowl-shaped surfaces have positive Gauss curvature.

Elliptic and hyperbolic geometry

The Euclidean, hyperbolic, and elliptic plane geometries obtained from variations of Hilbert's axioms (see [4] and [3]) would correspond to surfaces (Riemannian 2-manifolds) with constant Gauss curvature. The xy -plane has constant Gauss curvature $K = 0$. The unit sphere has constant Gauss curvature $K = +1$ (see Figure 4), and a model for the elliptic geometry axioms in Appendix A of [3] can be obtained by identifying antipodal points on the unit sphere. This is sometimes called the projective plane.

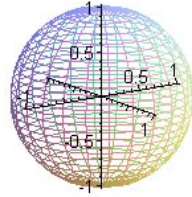

Figure 4. The sphere has constant positive Gauss curvature.

Surfaces with constant negative Gauss curvature are more difficult to construct. The pseudosphere is a surface with constant Gauss curvature $K = -1$ (see Figure 5, which is a graph of the parametric equations $x = \cos u \sin v$, $y = \sin u \sin v$, $z = \ln \tan (v/2) + \cos v$).

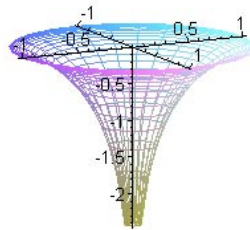

Figure 5. The pseudosphere has constant negative Gauss curvature.

The pseudosphere has the same local geometry as the hyperbolic plane, but the global geometry is very different (e.g., the pseudosphere has tiny circles with no centers). The hyperbolic plane is generally visualized through a projection like the Poincaré disk (see Figure 6).

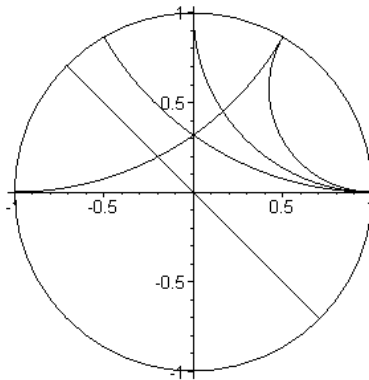

Figure 6. The Poincaré disk is a projection of the hyperbolic plane.

Geometric formulas in the different geometries

One characteristic difference between the three geometries is reflected in the angle sum of a triangle. In Euclidean geometry, the angle sum is 180° . It is smaller than this in hyperbolic geometry and larger in elliptic geometry. In particular for a triangle with area A and angles α , β , and γ , on the unit sphere

$$(1) \quad \alpha + \beta + \gamma = \pi + A,$$

and in the hyperbolic plane

$$(2) \quad \alpha + \beta + \gamma = \pi - A.$$

Similarly, the formula for the circumference of a circle with radius R differs among the geometries. On a surface with $K = -1$,

$$(3) \quad C_h = 2\pi \sinh(R),$$

and with $K = +1$

$$(4) \quad C_e = 2\pi \sin(R).$$

We can see the relationships in the graphs of Figure 7. In the Euclidean plane, the circumference of a circle is directly proportional to the radius. The circumference grows more quickly in the hyperbolic plane, and on the sphere, the circumference grows more slowly, and in fact, decreases for radii greater than $\pi/2$. We can interpret this as saying that the hyperbolic plane spreads out more quickly than the Euclidean plane, and the sphere spreads out more slowly. I think this interpretation is as important as the saddle/bowl characterization of curvature.

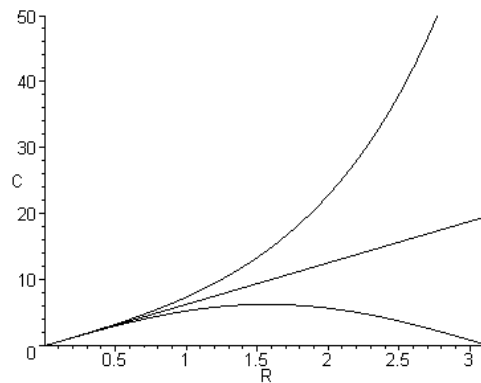

Figure 7. The circumferences of circles of radius R .

Comparisons through projections

The projection of the hyperbolic plane onto the Poincaré disk is such that the deformation of distances is symmetric about the origin. In particular, if a point is a distance r from the origin in the Poincaré disk, then its distance from the origin in the hyperbolic plane R is a function of r . The derivative of R , therefore, describes the relationship between distances in the Poincaré disk and distances in the hyperbolic plane. In particular, the circumference of a circle with radius r centered at the origin will be $2\pi r$ in the Poincaré disk and $2\pi r \frac{dR}{dr} = 2\pi \sinh(R)$ in the hyperbolic plane. This function R must therefore satisfy the separable differential equation

$$(5) \quad r \, dR/dr = \sinh(R),$$

and modulo a constant multiple, we must have

$$(6) \quad R = 2 \tanh^{-1} r = \ln((1+r)/(1-r))$$

or

$$(7) \quad r = \tanh(R/2).$$

It seems, therefore, that the Poincaré disk is the only Euclidean model that has a rotationally symmetric metric.

Since the circumference formula for a circle in elliptic geometry is similar to the formula in hyperbolic geometry, we can look for a rotationally symmetric metric for elliptic geometry. On a surface with constant curvature $K = +1$, the circumference of a circle of radius R is $C_e = 2\pi \sin(R)$. The differential equation resembles equation (5),

$$(8) \quad r \, dR/dr = \sin(R),$$

and so

$$(9) \quad R = 2 \tan^{-1} r$$

or

$$(10) \quad r = \tan(R/2).$$

This corresponds essentially to stereographic projection, so we see that stereographic projection and projection onto the Poincaré disk are comparable objects. In fact, stereographic projection restricted to the projective plane maps onto the unit disk (see Figure 8). Note that under this projection, antipodal points on the boundary of the unit disk are identified, so the lines shown are actually closed curves.

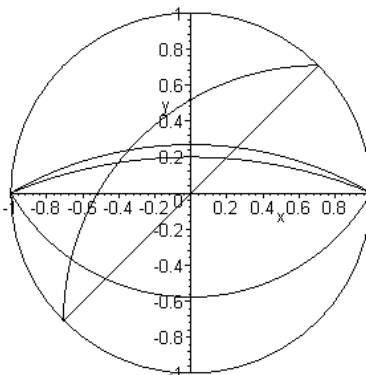

Figure 8. The image of the projective plane under stereographic projection.

Under these two projections, we can see the characteristic incidence properties of hyperbolic and elliptic geometry. The metric properties are represented

accurately, as well, but not in a linear fashion. Therefore, it is difficult to separate metric properties of the non-Euclidean geometries from the properties of the projection.

Impulse curvatures

Probably the most important aspect of non-Euclidean geometry that is not obvious from the projections is that lines are straight in both hyperbolic and elliptic geometry. One advantage of studying "lines" (geodesics) on curved surfaces is that the geodesic curvature is zero, and it is the space that curves rather than the lines. The big drawback, of course, is that the only curved surface that we can reasonably get our hands on is the sphere, and a Lénárt Sphere [7] costs \$70.

I would like to propose another source of examples. Instead of working with curved surfaces, consider surfaces with all of its curvature concentrated at isolated points. This allows us to construct models out of paper, since the curvature will be zero almost everywhere. The lines (geodesics) on these surfaces are also very naturally straight. The simplest example would be a cone. Here the geometry is mostly Euclidean, but also elliptic. The basic idea here actually predates Gaussian curvature, and is due to Descartes (see [2]). It also matches amazingly well with the big Gaussian curvature formula from the Gauss-Bonnet theorem. The standard terminology in this context uses terms like angle defect. I prefer the term **impulse curvature**.

Impulse functions

Impulse functions are used in applications where a phenomena acts over a very short period of time (see [1]). In such instances, it is more convenient, and probably more accurate, to assume that this action is instantaneous. The corresponding impulse function must have properties that the usual real-valued function does not. For example, an impulse function δ would have constants t_0 and k such that $\delta(t) = 0$ if $t \neq t_0$, and $\delta(t) = \infty$ if $t = t_0$, and the integral of δ is k over any interval containing t_0 .

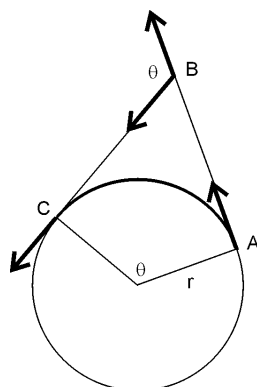

Figure 9. Impulse curvature for a curve.

Impulse curvature for curves

We will start by defining impulse curvature for curves. Consider Figure 9. The circle in Figure 9 has radius r , so its curvature is $\kappa = 1/r$. Since the curvature is the rate at which the tangent vector changes direction, if we integrate the curvature from point A to point B, we get the total change in direction for the tangent vector. Since the curvature is constant, this integral is simply the length of the arc times the curvature, and

$$\text{total curvature} = r \theta 1/r = \theta.$$

Therefore, from A to C the tangent vector has turned to the left θ radians.

The polygonal curve ABC is straight everywhere except at B . Since the segment AB is tangent to the circle at A and the segment BC is tangent to the circle at C , the initial and terminal tangent vectors are the same as for the arc AC . The total change in direction along the path ABC , therefore, must be θ . Clearly, all of this change occurs at the point B , where the curvature is, in some sense, infinite. If there is a curvature function for the path ABC , then it must be an impulse function. The curvature is zero everywhere except at B , where the curvature is infinite, and the integral of this curvature function is θ . We will say that the path ABC has **impulse curvature** θ at B .

An application of this concept (a.k.a. angle defect) concerns angle sums of polygons, which are different depending on the number of sides. The angle sum of a triangle in the plane is π radians. For a quadrilateral, it is 2π , and for a pentagon, it is $3\pi/2$. It is easily shown that the total impulse curvature for any polygon in the plane is 2π . Here, integrating curvature around a polygon is equivalent to summing the impulse curvatures at the vertices.

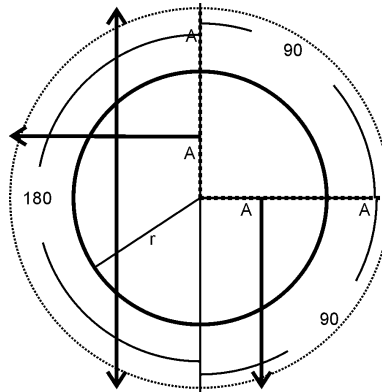

Figure 10. We can make a cone by removing a wedge.

Impulse Gauss curvature

The surface of a cone has zero Gauss curvature everywhere except at the vertex, where the curvature is, in some sense, infinite. The Gauss curvature function K for a cone must therefore be a 2-dimensional impulse function. All that needs to be determined is the value of the integral around the vertex. We can get a pretty good idea of what it should be from an example. In Figure 10, we have the ingredients for a cone. The cone is formed by removing the 90° wedge in the upper right and identifying the two rays bounding the wedge. The fact that the Gauss curvature is zero everywhere (except at the vertex) corresponds to the fact that this cone is constructed out of a flat piece of paper.

We can compute what the impulse Gauss curvature needs to be from the Gauss-Bonnet theorem. For a simple closed curve C bounding a simply connected region D on a smooth surface, the Gauss-Bonnet theorem states that the Gauss curvature K of the surface and the geodesic curvature κ (curvature within the surface) of the curve are related by the formula

$$(11) \quad \int_D K \, dA = 2\pi - \int_C \kappa \, ds.$$

The circle of radius r in Figure 10 has geodesic curvature $\kappa = 1/r$. Its circumference is $2\pi r$, and on the cone, after removing a quarter of it, the circumference is $3\pi r/4$. Therefore,

$$(12) \quad \int_D K \, dA = 2\pi - 3\pi r/4 \cdot 1/r = \pi/2 \text{ radians} = 90^\circ.$$

We will say that the **impulse Gauss curvature** at the vertex of this cone is $\pi/2$ radians or 90° . The derivative formulas for the trig functions assume radian measure, but other than that, there is no essential difficulty in switching back and forth between degrees and radians. The Gauss-Bonnet theorem is simpler in radians, of course, but it seems to be more convenient to work in degrees otherwise.

It should be clear that there is nothing special about 90° . So if we remove a θ -wedge, then the impulse Gauss curvature should be θ . This all indicates several important insights into the concept of Gauss curvature. One is that the natural units for Gauss curvature should be units of angle measure, although the definition suggests radians squared. Another is that a positive Gauss curvature can be thought of in terms of a sector of space missing (relative to Euclidean geometry). Of course on a smooth surface, the sectors are infinitesimal, and they are not all removed from a single point.

Also in Figure 10 are several lines. On the cone, these become two geodesics. Note that they are both locally straight, and they exhibit elliptic behavior. Here we see that having "less space" around the vertex has a fundamental effect on the relationship between lines.

Lines near an elliptic cone point

Forming a cone by removing a wedge leaves a vertex with positive impulse Gauss curvature. We will call the vertex an **elliptic cone point**. The behavior of lines near an elliptic cone point will exhibit behavior associated with lines in an elliptic geometry.

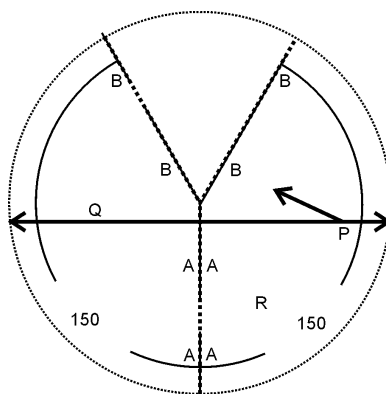

Figure 11. A cone with impulse Gauss curvature 60° .

In Figure 11, we have a cone with a 60° wedge removed, so the vertex will have positive impulse Gauss curvature $+60^\circ = +\pi/3$ radians. Cutting along the heavy dotted lines will allow us to draw the geodesics easily. Since this surface is flat everywhere (except at the cone point), geodesics are straight in the

Euclidean sense. We can draw them with a ruler. To extend a geodesic across a cut, line up the edges and draw the geodesic straight across with a ruler.

At the point P in Figure 11 is the start of a geodesic. With a ruler, continue it across the cut marked B and extend it as far as possible. This geodesic should intersect the other geodesic drawn near the letter Q . This forms a 2-gon PQ .

With a protractor, measure the impulse curvatures at P and Q . These should be around 145° and 155° . Since the 2-gon PQ encloses the elliptic vertex with impulse Gauss curvature 60° , we can check the Gauss-Bonnet theorem.

On the curve, the curvature is zero everywhere except for the two impulse curvatures. Therefore, integrating around the 2-gon is equivalent to summing the impulse curvatures, $\int_{PQ} \kappa ds = 145^\circ + 155^\circ$. Similarly, if D is the disk bounded by the 2-gon PQ , then $\int_D K dA = 60^\circ$. We have then, $60^\circ = 360^\circ - (145^\circ + 155^\circ)$.

Draw segments QR and PR . Note that there are two triangles PQR , since there are two segments QR . Note also that these two triangles are not congruent, but they satisfy the SAS criterion. Furthermore, since one of the triangles contains the elliptic cone point and the other does not, their angle sums and total impulse curvatures are different.

Lines around a hyperbolic cone point

Adding a wedge creates a "cone" with a kind of saddle shape. The result is an impulse Gauss curvature that is negative, and we will call the vertex a hyperbolic cone point. The behavior of lines near a hyperbolic cone point is similar to that of lines in a hyperbolic geometry.

In Figures 12 and 13, we have the ingredients for a cone with impulse Gauss curvature -60° .

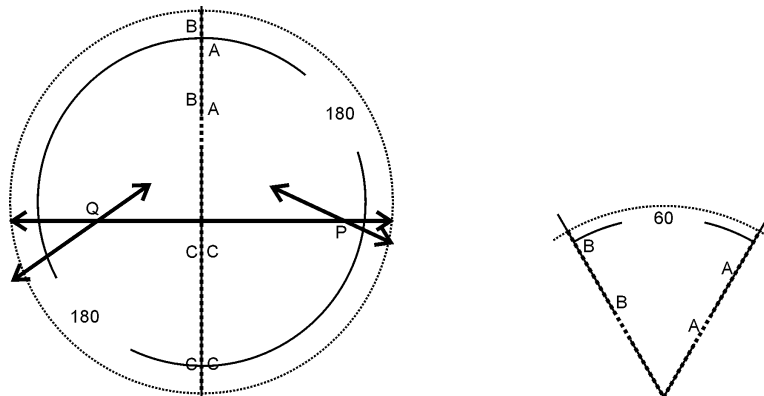

Figures 12 and 13. Adding a 60° wedge creates a cone point with impulse Gauss curvature -60° .

Cut along the heavy dotted lines and continue the geodesics indicated at P and Q . These should be parallel (i.e., they do not intersect).

Check the Gauss-Bonnet theorem by considering a quadrilateral that contains the hyperbolic cone point.

An example with multiple cone points

There are hardly any restrictions on constructing surfaces with multiple cone points (I don't think you can construct one with total Gauss curvature greater than 2π), and I think it would be helpful for students to be able construct counter-examples to theorems in Euclidean geometry.

My interest in flat surfaces with cone points began with a search for examples of Smarandache geometries. My book [5], which can be downloaded for free, contains some explorations in this context similar to the ones presented here. One example that I thought was interesting had something that I called a **hyperbolic point**.

A Smarandache Geometry is a geometry which has at least one smarandachely denied axiom (1969).

An axiom is said smarandachely denied if the axiom behaves in at least two different ways within the same space (i.e., validated and invalidated, or only invalidated but in multiple ways).

Thus, as a particular case, Euclidean, Lobachevsky-Bolyai-Gauss, and Riemannian geometries may be united altogether, in the same space, by some Smarandache geometries. These last geometries can be partially Euclidean and partially Non-Euclidean.

One of the first things proved in hyperbolic geometry is that through a point P not on a line l , there are infinitely many lines parallel to l . Hilbert's hyperbolic axiom requires only two (see [4]), but it is easily shown that all of the lines between these two parallels are also parallel. Smarandache wondered if there were any manifolds where there were only finitely many parallels (see [9]). My example has exactly two, but uses cone points. A variation of this example follows. I was later able to extend this to smooth surfaces (see [6]).

Since the cone points are parts of the space, we need to define how a geodesic passes through one. We use the **straightest geodesic** concept of [8], which says that the geodesic should make two equal angles at the cone point. For example, around a cone point with impulse curvature -60° , there is an "extra" 60° for a total of 420° . A geodesic passing through this cone point would make two 210° (straight) angles.

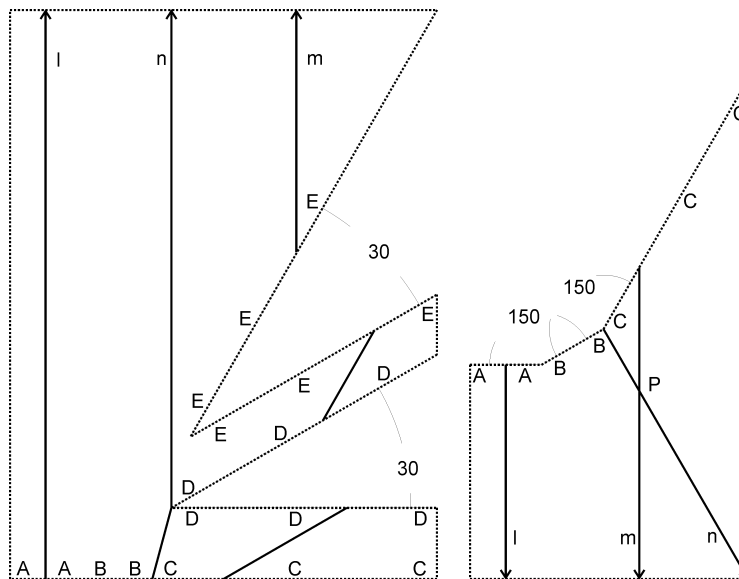

Figures 14 and 15. The lines m and n are the only lines through P that are parallel to l .

In Figures 14 and 15, the endpoints of the segment marked B are hyperbolic cone points with impulse Gauss curvature -30° , and the endpoints of the rays marked D and E are elliptic cone points with impulse Gauss curvature $+30^\circ$. The line n passes through one hyperbolic cone point making two 195° angles and one elliptic cone point making two 165° angles. This line n should look straight after the edges have been identified.

Also after the edges have been identified, it should be clear that both lines m and n are parallel to l . It is also true that every other line through P will intersect l . Draw in a couple before taping up the surface to verify this.

After identifying the edges, note that the lines l and m and the boundaries of the diagram form a quadrilateral with four right angles. Is it a rectangle? Is it a parallelogram?

References

1. W.E. Boyce and R.C. DiPrima, *Elementary Differential Equations and Boundary Value Problems*, John Wiley and Sons, New York, 1992.
2. H. Gottlieb, All the way with Gauss-Bonnet and the sociology of mathematics, *The American Mathematical Monthly* 103 (6), 457-469, 1996.
3. M.J. Greenberg, *Euclidean and Non-Euclidean Geometries*, W.H. Freeman and Company, New York, 1974.
4. D. Hilbert, *Foundations of Geometry*, Open Court, La Salle, IL, 1971.
5. H. Iseri, *Smarandache Manifolds*, American Research Press, Rehoboth, NM, USA, 2002. (available at www.gallup.unm.edu/~smarandache/Iseri-book.pdf)
6. H. Iseri, A finitely hyperbolic point on a smooth manifold (dvi-preprints available).
7. Lénárt Sphere, Key Curriculum Press, www.keypress.com
8. K. Polthier and M. Schmies, Straightest geodesics on polyhedral surfaces, *Mathematical Visualizations*, 1998.
9. F. Smarandache, *Paradoxist Mathematics, Collected Papers (Vol. II, 5-28)*, University of Kishinev Press, 1997.

Department of Mathematics and Computer Information Science, Mansfield University, Mansfield PA 16933.

E-mail address: hiseri@mnsfld.edu