

Can the efficiency of an arbitrary reversible cycle be equal to the efficiency of the enclosing Carnot cycle? Part - B

P. Radhakrishnamurty
 282, Duo Marvel Layout, Ananthapuragate, Yelahanka,
 Bangalore -560064, India. E-Mail: padvala1941@yahoo.com

Abstract

Calculation of efficiency of reversible cycles in thermodynamics remains a controversial issue. The basic question is this: Do different reversible heat engines, operating between maximum and minimum temperatures T_H and T_L , respectively, have different values of efficiency? We demonstrate in this article that the answer is in the negative and that all such cycles have equal efficiencies. In other words, no two reversible cycles operating between maximum and minimum temperatures of T_H and T_L respectively, can have unequal efficiencies.

Key words: Thermodynamics, Reversible cycle efficiency, Carnot cycle efficiency

1. Introduction

Ever since the efficiency of Carnot cycle is defined in such a way that it is less than one, troubles started. In fact, such a definition was forced upon, as a necessary consequence of rejecting the caloric theory of heat, according to which heat was a conserved quantity. However, we shall not go any further into those historical aspects. Calculation of efficiency of Stirling cycle *visa-vis* the calculation of efficiency of a Carnot cycle both of which operate between the same high temperature heat reservoirs (HRs) at T_H and low temperature HRs at T_L was among the earliest of this controversy that continues to engage the attention of researchers [1,2]. Other discussions focus on calculation of efficiency of different types of cycles - cycles in PV plane having a step of straight line with negative slope [3], 3-step cycles [2] etc. These calculations show that the efficiency of the chosen cycles to be less than the efficiency of the Carnot cycle operating between the maximum and minimum temperatures of the chosen cycle. The problem in general terms may be stated thus: Do different reversible heat engines, operating between maximum and minimum temperatures T_H and T_L , respectively, have different values of efficiency?

2. Two types of reversible cycles

Reversible thermodynamic cyclic processes that transform heat into mechanical work are of two types: 1. Carnot and 2. non-Carnot cyclic processes. In these cycles the system suffers heat interactions with HRs in the surroundings at n (≥ 2) different temperatures. Carnot cycles are two-temperature (2-T) cycles. At the end of a Carnot cycle, one HR, at temperature T_H suffers a loss of heat and the other HR at temperature T_L ($<T_H$) suffers a gain of heat. Non-Carnot cycles (n-T) cycles are n (>2) temperature cycles. At the end of an n-T cycle, HRs at two or more different temperatures suffer change of heat, although heat interaction occurs at more than two temperatures. All these cyclic processes may be depicted on a pressure-volume (PV) diagram; or more easily on a temperature-entropy (TS) diagram. We choose depiction on TS diagrams.

3. Efficiency of 3 - T cycles

The efficiency η_R , of a reversible cycle, such as the one shown in Fig. 1 is given by the expression [4]:

$$\eta_R = \frac{W}{Q_{in}} = \frac{\int dQ_{in} - \int dQ_{out}}{\int dQ_{in}} = \left[1 - \frac{\int dQ_{out}}{\int dQ_{in}} \right] < 1 \quad (1)$$

We show below that all reversible cycles, such as the one shown in Fig. 1, operating between maximum and minimum temperatures T_H and T_L respectively, have the same value of efficiency.

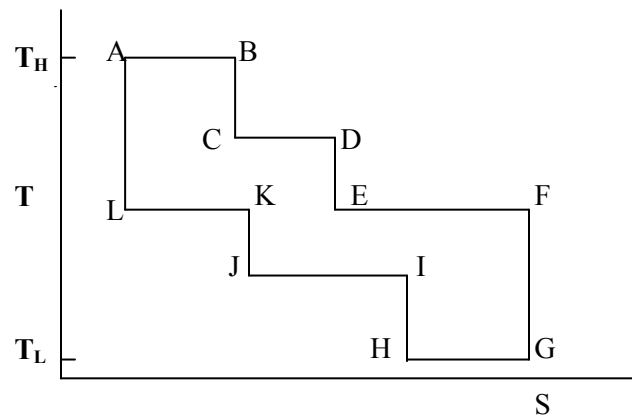

Fig. 1. T-S Diagram of a n-T reversible cycle.

To understand the theory underlying the calculation of efficiency of such an n-T cycle, it is important to understand the calculation for a simpler 3-T cycle. A 3-T cycle involving heat interaction at three temperatures T_H , T_X and T_L ($T_H > T_X > T_L$) is shown in Fig. 2. In this cycle, the system absorbs heat from a heat reservoir HR at temperature T_X in one portion (CD) of the cycle and rejects heat at T_X , in another portion (GH) of the same cycle. Therefore, HR at T_X suffers a net change of heat which could either be zero or positive or even negative; in Fig. 2 it is negative.

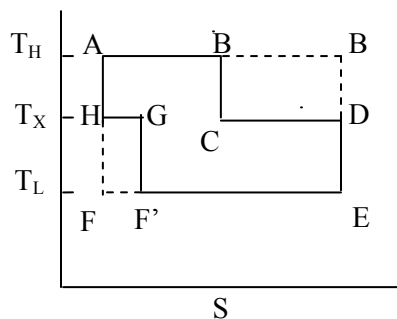

Fig. 2 A 3-T reversible cycle

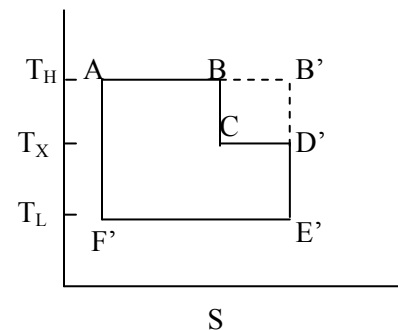

Fig. 3 Cycle in Fig.2 simplified

We redraw the cycle shown in Fig. 2 in a simpler manner as shown in Fig. 3 by sliding the lower cycle to the left so that GF' coincides with HF.

Only the net heat change suffered by HR at T_X , which also is the net heat interaction at T_X between the system and surroundings in a complete cycle, is reflected here. Applied to this 3-T cycle the efficiency is calculated using the expression:

$$\eta_R = \frac{W}{Q_H + Q_X} = \frac{Q_H + Q_X - Q_L}{Q_H + Q_X} = \left[1 - \frac{Q_L}{Q_H + Q_X} \right] < 1 \quad (2)$$

Where, Q_i represents the amount of heat interaction at temperature T_i . W represents the amount of work out put per cycle.

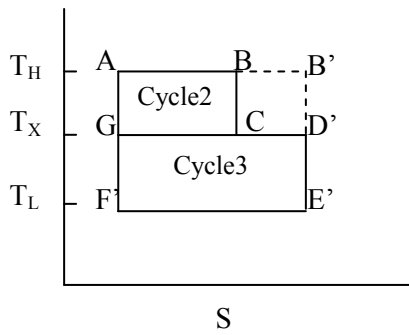

Fig. 4 Cycle in Fig. 3 is shown here as a combination of two Carnot cycles

The 3-T cycle ABCD'E'F'A, shown in Fig. 3 (called hereafter as cycle-1), may be considered as a combination of two Carnot cycles ABCGA and GCD'E'F'G, as is shown in Fig. 4. In cycle ABCGA (called hereafter as cycle-2), heat interactions occur at temperatures T_H and T_X and in cycle GCD'E'F'G (called hereafter as cycle-3), heat interactions occur at temperatures T_X and T_L . Relations (2), (3) below, apply to the two cycles, respectively [5].

$$Q_H : Q'_X : W_2 = T_H : T_X : (T_H - T_X) \quad \text{for cycle ABCGA} \quad (3)$$

$$Q_X : Q_L : W_3 = T_X : T_L : (T_X - T_L) \quad \text{for cycle GCD'E'F'G} \quad (4)$$

We can rewrite relations (2) and (3) as shown in relations (4) and (5), respectively.

$$n_1 Q_H : n_1 Q'_X : n_1 W_2 = T_H : T_X : (T_H - T_X) \quad (5)$$

$$n_2 Q_X : n_2 Q_L : n_2 W_3 = T_X : T_L : (T_X - T_L) \quad (6)$$

Where n_1 and n_2 are integers such that $n_1 Q'_X = n_2 Q_X$ [6].

As can be seen from relations (4) and (5) the ratio of $(T_H - T_X)$ to T_H does not depend on the value of n_1 and, the ratio of $(T_X - T_L)$ to T_L does not depend on the value of n_2 . So is the case with the efficiencies of cycles 2 and 3; they too do not depend on the values of n_1 and n_2 . Therefore, the efficiency of the composite cycle does not depend on the values of n_1 and n_2 .

The cycle consisting of n_1 cycles of cycle-2 and n_2 cycles of cycle-3 is a Carnot cycle [6], (note, HR at T_X suffers no change because $n_1Q'_X = n_2Q_X$). Therefore, the efficiency of the 3-T composite cycle viz., cycle-1, is the same as the efficiency of the Carnot cycle that involves heat interactions at T_H and T_L . Since T_X can have any value satisfying the condition $T_H > T_X > T_L$, it follows that all 3-T cycles that operate with maximum and minimum temperatures T_H and T_L respectively, have the same efficiency.

4. Efficiency of n-T cycles

We can divide a given reversible n-T ($n \geq 3$) cycle into a network of (combination of) Carnot cycles. Taking two Carnot cycles with heat interaction at a common temperature, we can reduce them to a single Carnot cycle. Repeating this procedure we can gradually reduce the given n-T cycle to a Carnot cycle, operating between the maximum and minimum temperatures of the given n-T cycle. Consequently, any number of different reversible cycles operating between a maximum temperature T_H and a minimum temperature T_L could be reduced to one and the same Carnot cycle operating between temperatures T_H and T_L . The efficiency of an arbitrary n-T reversible cycle ($n > 2$) is thus seen to be the same as the efficiency of the Carnot cycle that operates with HRs of the highest and the lowest temperatures of heat interaction in the given n-T cycle.

Thus, it follows from the above that all reversible cycles operating between the same maximum and minimum temperatures have the same efficiency. Stated differently, no two reversible cycles operating between the same maximum and minimum temperatures can have different values of efficiency.

This result is in contradiction with the conventional results that state: Of all the reversible heat engines that interact with HRs at $n (>2)$ different temperatures the highest temperature being T_H and the lowest temperature being T_L , the Carnot engine interacting with HRs at T_H and T_L has the highest efficiency.

It is possible that this result can open up new vistas of further research.

5. References

1. C. Salter, J. Chem. Educ., **77** (2000), 1027-1031.
2. K. Seidman and T. R. Michalik, J. Chem. Educ. **68** (1991), 208-211.
3. R. H. Dickerson and J. Mottman, Am. J. Phys. **62** (1994), 558-562.
4. M. C. Tobin, Am. J. Phys. **37** (1969), 1115-1117.
5. M. Plank, A treatise on Thermodynamics, 3 ed., Dover, NY (1945).
6. E. Fermi, Thermodynamics, Dover, NY (1956).