

Florentin Smarandache

Extenics in Higher Dimensions

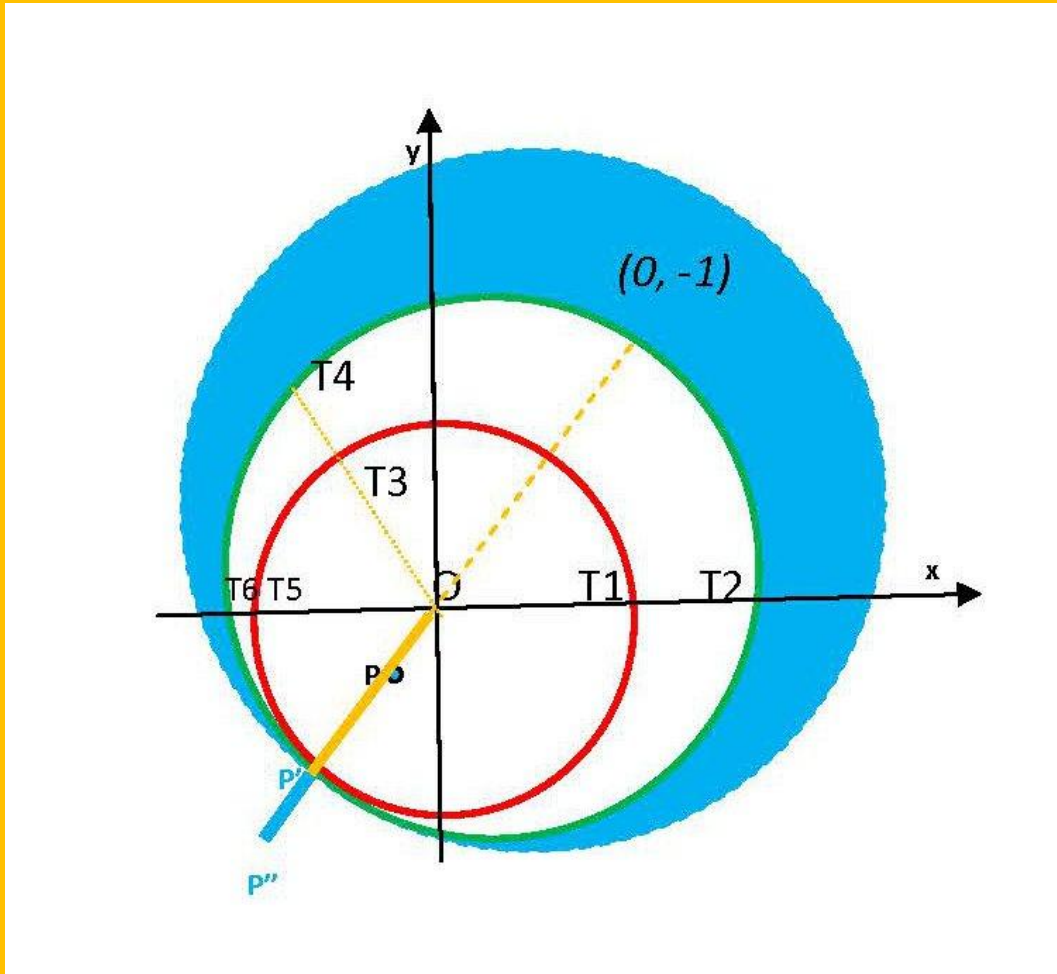

Institute of Extenics and Innovation Methods

Institute of Extenics and Innovation Methods

Guangdong University of Technology

Extenics in Higher Dimensions

Florentin Smarandache
author and editor

**University of New Mexico
Arts & Science Division
705 Gurley Dr.
Gallup, NM 87301, USA
E-mail: smarand@unm.edu**

2012

This book can be ordered on paper or electronic formats from:

*Education Publisher
1313 Chesapeake Avenue
Columbus, Ohio 43212
USA
Tel. (614) 485-0721*

Copyright 2012 by *Education Publisher* and the *Authors for their papers*

Front and back covers by the Editor

Peer-Reviewers:

Xingsen Li, School of Management, Ningbo Institute of Technology, Zhejiang University, Ningbo, China.

Qiao-Xing Li, School of Management, Lanzhou University, Lanzhou 730000 China.

Zhongbiao Xiang, School of Management, Zhejiang University, Hangzhou, China.

ISBN: 9781599732039

Printed in the United States of America

Contents

Contribution to Extenics (Preface by Florentin Smarandache): 4

1. *Generalizations of the Distance and Dependent Function in Extenics to 2D, 3D, and n-D*, by Florentin Smarandache: 22
2. *Applications of Extenics to 2D-Space and 3D-Space*, by Florentin Smarandache, Victor Vlădăreanu: 39
3. *Generalization of the Dependent Function in Extenics for Nested Sets with Common Endpoints to 2D-Space, 3D-Space, and generally to n-D-Space*, by Florentin Smarandache: 52
4. *Generalizations in Extenics of the Location Value and Dependent Function from A Single Finite Interval to 2D, 3D, and n-D Spaces*, by Florentin Smarandache, Mihai Liviu Smarandache: 60
5. *Extention Transformation Used in I Ching*, by Florentin Smarandache: 69
6. *Extenics in Conventional and Nonconventional [Romanian]*, by Florentin Smarandache, Tudor Păroiu: 79
7. *Extension Communication for Solving the Ontological Contradiction between Communication and Information*, by Florentin Smarandache, Ștefan Vlăduțescu: 99-112

Contribution to Extenics

Preface by Florentin Smarandache

During my research period in the Summer of 2012 at the Research Institute of Extenics and Innovation Methods, from Guangdong University of Technology, in Guangzhou, China, I have introduced the Linear and Non-Linear Attraction Point Principle and the Network of Attraction Curves, have generalized the 1D Extension Distance and the 1D Dependent Function to 2D, 3D, and in general to n-D Spaces, and have generalized Qiao-Xing Li's and Xing-Sen Li's definitions of the Location Value of a Point and the Dependent Function of a Point on a Single Finite Interval from one dimension (1D) to 2D, 3D, and in general n-D spaces.

Then I used the Extenics, together with Victor Vlădăreanu, Mihai Liviu Smarandache, Tudor Păroiu, and Ștefan Vlăduțescu, in 2D and 3D spaces in technology, philosophy, and information theory.

Extenics is the science of solving contradictory problems in many fields set up by Prof. Cai Wen in 1983.

1. The **Linear and Non-Linear Attraction Point Principle** is the following:

Let S be an arbitrary set in the universe of discourse U of any dimension, and the optimal point $O \in S$. Then each point $P(x_1, x_2, \dots, x_n)$, $n \geq 1$, from the universe of discourse (linearly or non-linearly) tends towards, or is attracted by, the optimal point O , because the optimal point O is an ideal of each point.

There could be one or more linearly or non-linearly trajectories (curves) that the same point P may converge on towards O . Let's call all such points' trajectories as the **Network of Attraction Curves (NAC)**.

It is a kind of convergence/attraction of each point towards the optimal point. There are classes of examples and applications where such attraction point principle may apply.

If this principle is good in all cases, then there is no need to take into consideration the center of symmetry of the set S , since for example if one has a 2D factory piece which has heterogeneous material density, then its center of weight (barycenter) is different from the center of symmetry.

1. I generalized in the track of Cai Wen's idea the extension 1D-set to an extension n-D-set, and defined the Linear (or Non-Linear) **Extension n-D-Distance** between a point $P(x_1, x_2, \dots, x_n)$ and the n-D-set S as $\rho(x_1, x_2, \dots, x_n, S)$ on the linear (or non-linear) direction determined by the point P and the optimal point O (the line PO , or respectively the curvilinear PO) in the following way:

- a) $\rho(x_1, x_2, \dots, x_n, S)$ = the *negative distance* between P and the set frontier, if P is inside the set S ;

- b) $\rho(x_1, x_2, \dots, x_n, S) = 0$, if P lies on the frontier of the set S ;
- c) $\rho(x_1, x_2, \dots, x_n, S) =$ the *positive distance* between P and the set frontier, if P is outside the set.

He got the following **properties** of the Extension n -D-Distance:

- a) It is obvious from the above definition of the extension n -D-distance between a point P in the universe of discourse and the extension n -D-set S that:
 - i) Point $P(x_1, x_2, \dots, x_n) \in \text{Int}(S)$ iff $\rho(x_1, x_2, \dots, x_n, S) < 0$;
 - ii) Point $P(x_1, x_2, \dots, x_n) \in \text{Fr}(S)$ iff $\rho(x_1, x_2, \dots, x_n, S) = 0$;
 - iii) Point $P(x_1, x_2, \dots, x_n) \notin S$ iff $\rho(x_1, x_2, \dots, x_n, S) > 0$.
- b) Let S_1 and S_2 be two extension sets, in the universe of discourse U , such that they have no common end points, and $S_1 \subset S_2$. I assumed they have the same optimal points $O_1 \equiv O_2 \equiv O$ located in their center of symmetry. Then for any point $P(x_1, x_2, \dots, x_n) \in U$ one has:

$$\rho(x_1, x_2, \dots, x_n, S_1) \geq \rho(x_1, x_2, \dots, x_n, S_2).$$

Then I proceeded to the generalization of the dependent function from $1D$ -space to Linear (or Non-Linear) n -D-space Dependent Function, using the previous notations.

- 2. The **Linear (or Non-Linear) Dependent n -D-Function** of point $P(x_1, x_2, \dots, x_n)$ along the curve c , is:

$$K_{nD}(x_1, x_2, \dots, x_n) = \frac{\rho_c((x_1, x_2, \dots, x_n), S_2)}{\rho_c((x_1, x_2, \dots, x_n), S_2) - \rho_c((x_1, x_2, \dots, x_n), S_1)}$$

(where c may be a curve or even a line)

which has the following **property**:

- a) If point $P(x_1, x_2, \dots, x_n) \in \text{Int}(S_1)$, then $K_{nD}(x_1, x_2, \dots, x_n) > 1$;
- b) If point $P(x_1, x_2, \dots, x_n) \in \text{Fr}(S_1)$, then $K_{nD}(x_1, x_2, \dots, x_n) = 1$;
- c) If point $P(x_1, x_2, \dots, x_n) \in \text{Int}(S_2 - S_1)$, then $K_{nD}(x_1, x_2, \dots, x_n) \in (0, 1)$;
- d) If point $P(x_1, x_2, \dots, x_n) \in \text{Int}(S_2)$, then $K_{nD}(x_1, x_2, \dots, x_n) = 0$;
- e) If point $P(x_1, x_2, \dots, x_n) \notin \text{Int}(S_2)$, then $K_{nD}(x_1, x_2, \dots, x_n) < 0$.

3. Extension Distance in 2D-Space.

Geometrically studying this extension distance, I found the following principle that Prof. Cai has used in 1983 when defining the 1D Extension Distance:

$\rho(x_0, X) =$ the *geometric distance* between the point x_0 and the closest extremity point of the interval $\langle a, b \rangle$ to it (going in the direction that connects x_0 with the optimal point), distance taken as negative if $x_0 \in \langle a, b \rangle$, and as positive if $x_0 \notin \langle a, b \rangle$.

Instead of considering a segment of line AB representing the interval $\langle a, b \rangle$ in $1R$, I considered a rectangle $AMBN$ representing all points of its surface in $2D$. Similarly as for $1D$ -space, the rectangle in $2D$ -space may be closed (i.e. all points lying on its frontier belong to it), open (i.e. no point lying on its frontier belong to it), or partially closed (i.e. some points lying on its frontier belong to it, while other points lying on its frontier do not belong to it).

Let's consider two arbitrary points $A(a_1, a_2)$ and $B(b_1, b_2)$. Through the points A and B one draws parallels to the axes of the Cartesian system XY and one thus forms a rectangle $AMBN$ whose one of the diagonals is just AB .

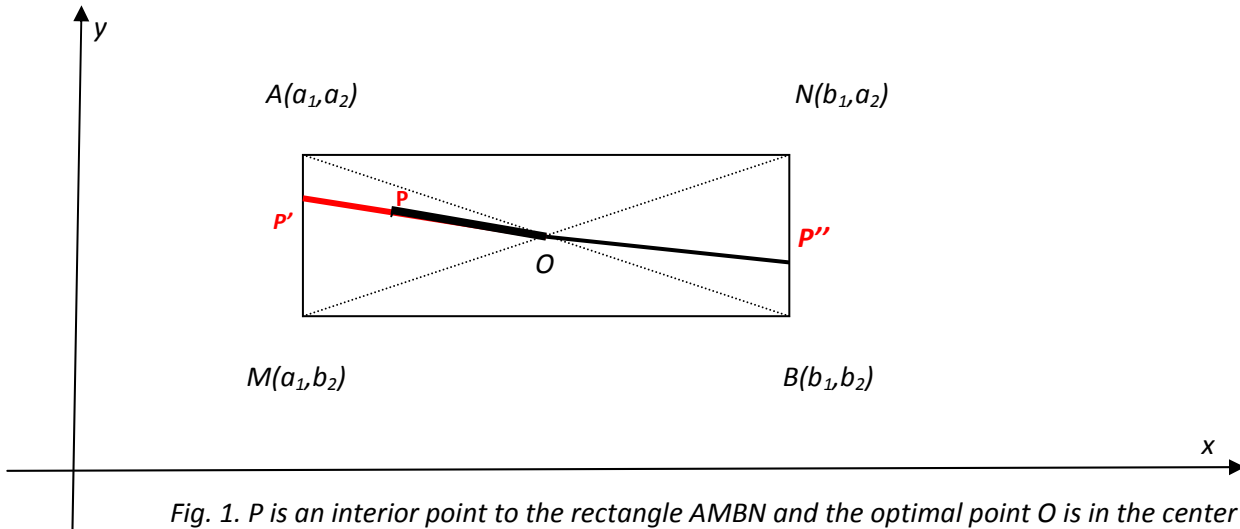

Fig. 1. P is an interior point to the rectangle $AMBN$ and the optimal point O is in the center of symmetry of the rectangle

Let's note by O the midpoint of the diagonal AB , but O is also the center of symmetry (intersection of the diagonals) of the rectangle $AMBN$.

Then one computes the distance between a point $P(x_0, y_0)$ and the rectangle $AMBN$.

One can do that following the same principle as Dr. Cai Wen did:

- compute the distance in $2D$ (two dimensions) between the point P and the center O of the rectangle (intersection of rectangle's diagonals);
- next compute the distance between the point P and the closest point (let's note it by P') to it on the frontier (the rectangle's four edges), in the side of the optimal point, of the rectangle $AMBN$;

this step can be done in the following way:

considering P' as the intersection point between the line PO and the frontier of the rectangle, and taken among the intersection points that point P' which is the closest to P ; this case is entirely consistent with Dr. Cai's approach in the sense that when reducing from a $2D$ -space problem to two $1D$ -space problems, one exactly gets his result.

The Extension $2D$ -Distance, for $P \neq O$, will be:

$$\rho((x_0, y_0), AMBN) = d(\text{point } P, \text{rectangle } AMBN) = |PO| - |P'O| = \pm |PP'|$$

- i) which is equal to the negative length of the red segment $|PP'|$ in Fig. 1 when P is interior to the rectangle $AMBN$;
- ii) or equal to zero when P lies on the frontier of the rectangle $AMBN$ (i.e. on edges AM , MB , BN , or NA) since P coincides with P' ;
- iii) or equal to the positive length of the blue segment $|PP'|$ in Fig. 2 when P is exterior to the rectangle $AMBN$.

where $|PO|$ means the classical 2D-distance between the point P and O , and similarly for $|P'O|$ and $|PP'|$.

The Extension 2D-Distance, for the optimal point (i.e. $P=O$), will be $\rho(O, AMBN) = d(\text{point } O, \text{rectangle } AMBN) = - \max d(\text{point } O, \text{point } M \text{ on the frontier of } AMBN)$.

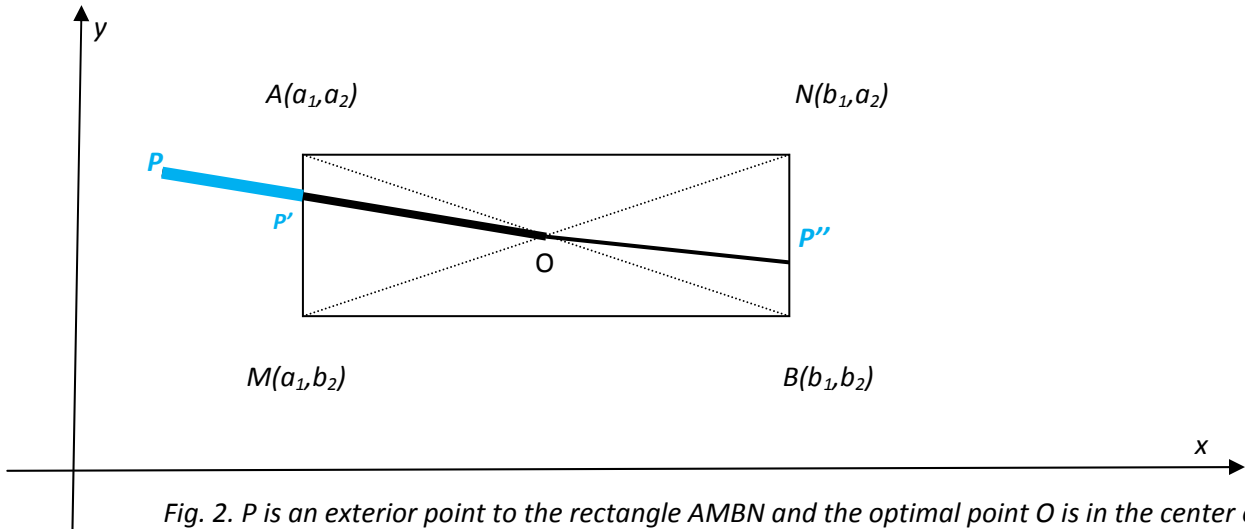

Fig. 2. P is an exterior point to the rectangle $AMBN$ and the optimal point O is in the center of symmetry of the rectangle

4. Properties.

As for 1D-distance, the following properties hold in 2D:

a. Property 1.

- a) $(x, y) \in \text{Int}(AMBN)$ iff $\rho((x, y), AMBN) < 0$, where $\text{Int}(AMBN)$ means interior of $AMBN$;
- b) $(x, y) \in \text{Fr}(AMBN)$ iff $\rho((x, y), AMBN) = 0$, where $\text{Fr}(AMBN)$ means frontier of $AMBN$;
- c) $(x, y) \notin AMBN$ iff $\rho((x, y), AMBN) > 0$.

b. Property 2.

Let $A_0M_0B_0N_0$ and $AMBN$ be two rectangles whose sides are parallel to the axes of the Cartesian system of coordinates, such that they have no common end points, and $A_0M_0B_0N_0 \subset AMBN$. I assumed they have the same optimal points $O_1 \equiv O_2 \equiv O$ located in the center of symmetry of the two rectangles.

Then for any point $(x, y) \in \mathbb{R}^2$ one has $\rho((x, y), A_0M_0B_0N_0) \geq \rho((x, y), AMBN)$.

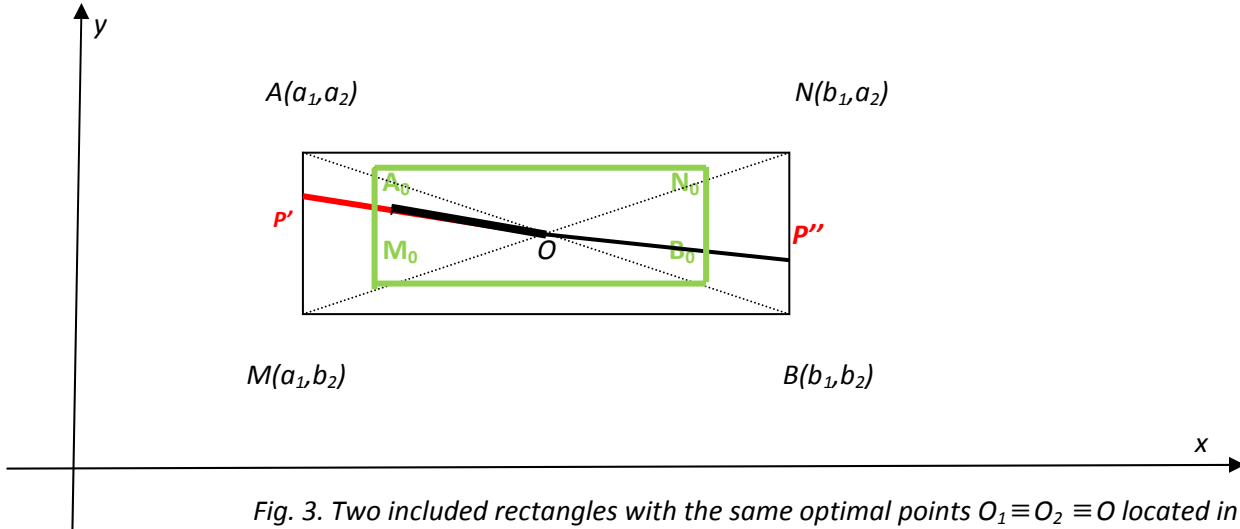

Fig. 3. Two included rectangles with the same optimal points $O_1 \equiv O_2 \equiv O$ located in their common center of symmetry

5. Dependent 2D-Function.

Let $A_0M_0B_0N_0$ and $AMBN$ be two rectangles whose sides are parallel to the axes of the Cartesian system of coordinates, such that they have no common end points, and $A_0M_0B_0N_0 \subset AMBN$.

The **Dependent 2D-Function** formula is:

$$K_{2D}(x, y) = \frac{\rho((x, y), AMBN)}{\rho((x, y), AMBN) - \rho((x, y), A_0M_0B_0N_0)}$$

a. Property 3.

Again, similarly to the Dependent Function in 1D-space, one has:

- a) If $(x, y) \in \text{Int}(A_0M_0B_0N_0)$, then $K_{2D}(x, y) > 1$;
- b) If $(x, y) \in \text{Fr}(A_0M_0B_0N_0)$, then $K_{2D}(x, y) = 1$;
- c) If $(x, y) \in \text{Int}(AMBN - A_0M_0B_0N_0)$, then $0 < K_{2D}(x, y) < 1$;
- d) If $(x, y) \in \text{Fr}(AMBN)$, then $K_{2D}(x, y) = 0$;
- e) If $(x, y) \notin AMBN$, then $K_{2D}(x, y) < 0$.

6. General Case in 2D-Space.

One can replace the rectangles by any finite surfaces, bounded by closed curves in 2D-space, and one can consider any optimal point O (not necessarily the symmetry center). Again, I assumed the optimal points are the same for this nest of two surfaces.

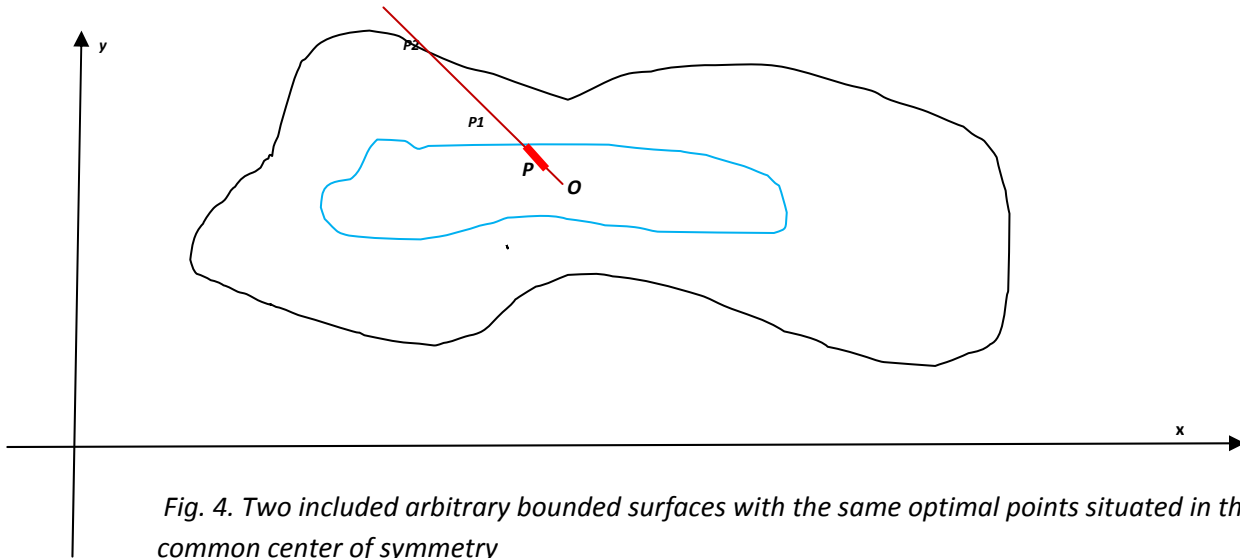

7. Linear Attraction Point Principle.

I have introduced the Attraction Point Principle, which is the following:

Let S be a given set in the universe of discourse U , and the optimal point $O \in S$. Then each point $P(x_1, x_2, \dots, x_n)$ from the universe of discourse tends towards, or is attracted by, the optimal point O , because the optimal point O is an ideal of each point.

That's why one computes the extension n -D-distance between the point P and the set S as $\rho(x_1, x_2, \dots, x_n, S)$ on the direction determined by the point P and the optimal point O , or on the line PO , i.e.:

- d) $\rho(x_1, x_2, \dots, x_n, S) =$ the *negative distance* between P and the set frontier, if P is inside the set S ;
- e) $\rho(x_1, x_2, \dots, x_n, S) = 0$, if P lies on the frontier of the set S ;
- f) $\rho(x_1, x_2, \dots, x_n, S) =$ the *positive distance* between P and the set frontier, if P is outside the set.

It is a kind of convergence/attraction of each point towards the optimal point. There are classes of examples where such attraction point principle works.

If this principle is good in all cases, then there is no need to take into consideration the center of symmetry of the set S , since for example if one has a 2D piece which has heterogeneous material density, then its center of weight (barycenter) is different from the center of symmetry.

Let's see below such example in the 2D-space:

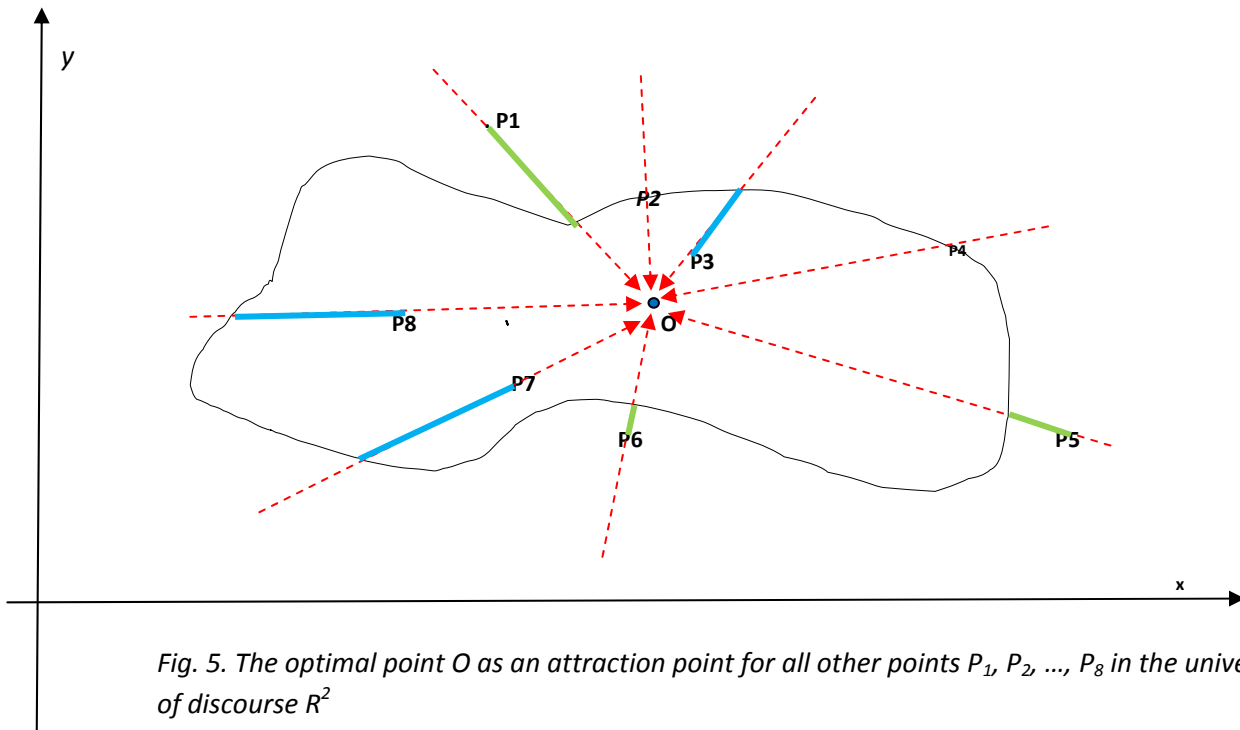

Fig. 5. The optimal point O as an attraction point for all other points P_1, P_2, \dots, P_8 in the universe of discourse R^2

8. Extension Distance in 3D-Space.

I further generalized to 3D-space the Extension Set and the Dependent Function. Assume one has two points $A(a_1, a_2, a_3)$ and $B(b_1, b_2, b_3)$ in 3D. Drawing through A and B parallel planes to the planes' axes (XY, XZ, YZ) in the Cartesian system XYZ I get a prism $AM_1M_2M_3BN_1N_2N_3$ (with eight vertices) whose one of the transversal diagonals is just the line segment AB . Let's note by O the midpoint of the transverse diagonal AB , but O is also the center of symmetry of the prism.

Therefore, from the line segment AB in 1D-space, to a rectangle $AMBN$ in 2D-space, and now to a prism $AM_1M_2M_3BN_1N_2N_3$ in 3D-space. Similarly to 1D- and 2D-space, the prism may be closed (i.e. all points lying on its frontier belong to it), open (i.e. no point lying on its frontier belong to it), or partially closed (i.e. some points lying on its frontier belong to it, while other points lying on its frontier do not belong to it).

Then one computes the distance between a point $P(x_0, y_0, z_0)$ and the prism $AM_1M_2M_3BN_1N_2N_3$.

One can do that following the same principle as Dr. Cai's:

- compute the distance in 3D (two dimensions) between the point P and the center O of the prism (intersection of prism's transverse diagonals);
- next compute the distance between the point P and the closest point (let's note it by P') to it on the frontier (the prism's lateral surface) of the prism $AM_1M_2M_3BN_1N_2N_3$;

considering P' as the intersection point between the line OP and the frontier of the prism, and taken among the intersection points that point P' which is the closest to P ; this case is entirely consistent with

Dr. Cai's approach in the sense that when reducing from 3D-space to 1D-space one gets exactly Dr. Cai's result;

- the Extension 3D-Distance will be: $d(P, AM_1M_2M_3BN_1N_2N_3) = |PO| - |P'O| = \pm |PP'|$, where $|PO|$ means the classical distance in 3D-space between the point P and O , and similarly for $|P'O|$ and $|PP'|$.

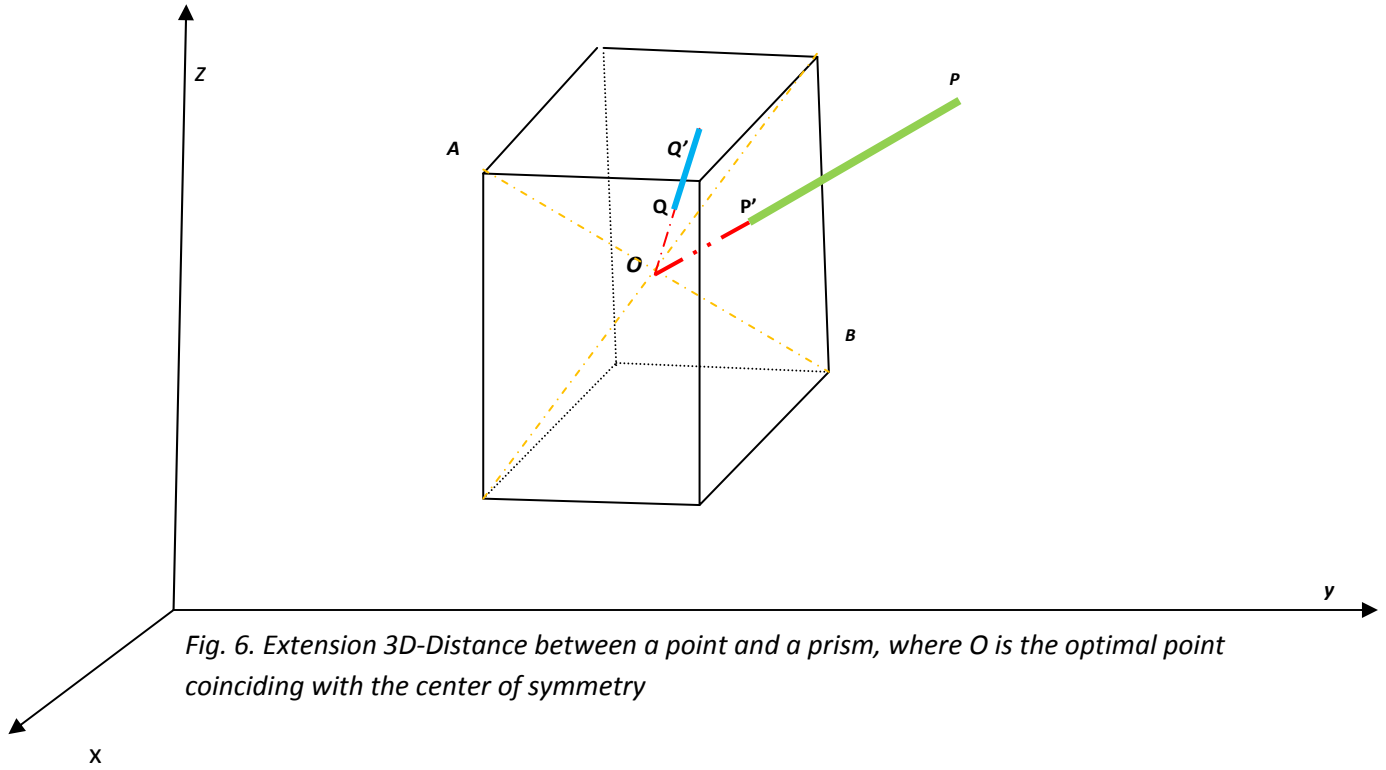

Fig. 6. Extension 3D-Distance between a point and a prism, where O is the optimal point coinciding with the center of symmetry

9. Property 4.

- $(x,y,z) \in \text{Int}(AM_1M_2M_3BN_1N_2N_3)$ iff $\rho((x, y, z), AM_1M_2M_3BN_1N_2N_3) < 0$, where $\text{Int}(AM_1M_2M_3BN_1N_2N_3)$ means interior of $AM_1M_2M_3BN_1N_2N_3$;
- $(x,y,z) \in \text{Fr}(AM_1M_2M_3BN_1N_2N_3)$ iff $\rho((x, y, z), AM_1M_2M_3BN_1N_2N_3) = 0$, where $\text{Fr}(AM_1M_2M_3BN_1N_2N_3)$ means frontier of $AM_1M_2M_3BN_1N_2N_3$;
- $(x,y,z) \notin AM_1M_2M_3BN_1N_2N_3$ iff $\rho((x, y, z), AM_1M_2M_3BN_1N_2N_3) > 0$.

10. Property 5.

Let $A_0M_{01}M_{02}M_{03}B_0N_{01}N_{02}N_{03}$ and $AM_1M_2M_3BN_1N_2N_3$ be two prisms whose sides are parallel to the axes of the Cartesian system of coordinates, such that they have no common end points, and $A_0M_{01}M_{02}M_{03}B_0N_{01}N_{02}N_{03} \subset AM_1M_2M_3BN_1N_2N_3$. I assumed they have the same optimal points $O_1 \equiv O_2 \equiv O$ located in the center of symmetry of the two prisms.

Then for any point $(x,y,z) \in R^3$ one has

$$\rho((x, y, z), A_0M_{01}M_{02}M_{03}B_0N_{01}N_{02}N_{03}) \geq \rho((x, y, z), AM_1M_2M_3BN_1N_2N_3).$$

11. The Dependent 3D-Function.

The last step is to devise the Dependent Function in 3D-space similarly to Dr. Cai's definition of the dependent function in 1D-space.

Let $A_0M_{01}M_{02}M_{03}B_0N_{01}N_{02}N_{03}$ and $AM_1M_2M_3BN_1N_2N_3$ be two prisms whose faces are parallel to the axes of the Cartesian system of coordinates XYZ , such that they have no common end points, such that $A_0M_{01}M_{02}M_{03}B_0N_{01}N_{02}N_{03} \subset AM_1M_2M_3BN_1N_2N_3$. I assume they have the same optimal points $O_1 \equiv O_2 \equiv O$ located in the center of symmetry of these two prisms.

The **Dependent 3D-Function** formula is:

$$K_{3D}(x, y, z) = \frac{\rho((x, y, z), AM_1M_2M_3BN_1N_2N_3)}{\rho((x, y, z), AM_1M_2M_3BN_1N_2N_3) - \rho((x, y, z), A_0M_{01}M_{02}M_{03}B_0N_{01}N_{02}N_{03})}$$

12. Property 6.

Again, similarly to the Dependent Function in 1D- and 2D-spaces, one has:

- f) If $(x, y, z) \in \text{Int}(A_0M_{01}M_{02}M_{03}B_0N_{01}N_{02}N_{03})$, then $K_{3D}(x, y, z) > 1$;
- g) If $(x, y, z) \in \text{Fr}(A_0M_{01}M_{02}M_{03}B_0N_{01}N_{02}N_{03})$, then $K_{3D}(x, y, z) = 1$;
- h) If $(x, y, z) \in \text{Int}(AM_1M_2M_3BN_1N_2N_3 - A_0M_{01}M_{02}M_{03}B_0N_{01}N_{02}N_{03})$, then $0 < K_{3D}(x, y, z) < 1$;
- i) If $(x, y, z) \in \text{Fr}(AM_1M_2M_3BN_1N_2N_3)$, then $K_{3D}(x, y, z) = 0$;
- j) If $(x, y, z) \notin AM_1M_2M_3BN_1N_2N_3$, then $K_{3D}(x, y, z) < 0$.

13. General Case in 3D-Space.

One can replace the prisms by any finite 3D-bodies, bounded by closed surfaces, and one considers any optimal point O (not necessarily the centers of surfaces' symmetry). Again, I assumed the optimal points are the same for this nest of two 3D-bodies.

14. Remark 2.

Another possible way, for computing the distance between the point P and the closest point P' to it on the frontier (lateral surface) of the prism $AM_1M_2M_3BN_1N_2N_3$ is by drawing a perpendicular (or a geodesic) from P onto the closest prism's face, and denoting by P' the intersection between the perpendicular (geodesic) and the prism's face.

And similarly if one has an arbitrary finite body B in the 3D-space, bounded by surfaces. One computes as in classical mathematics:

$$d(P, B) = \inf_{Q \in B} |PQ|$$

15. Linear Attraction Point Principle in 3D-Space.

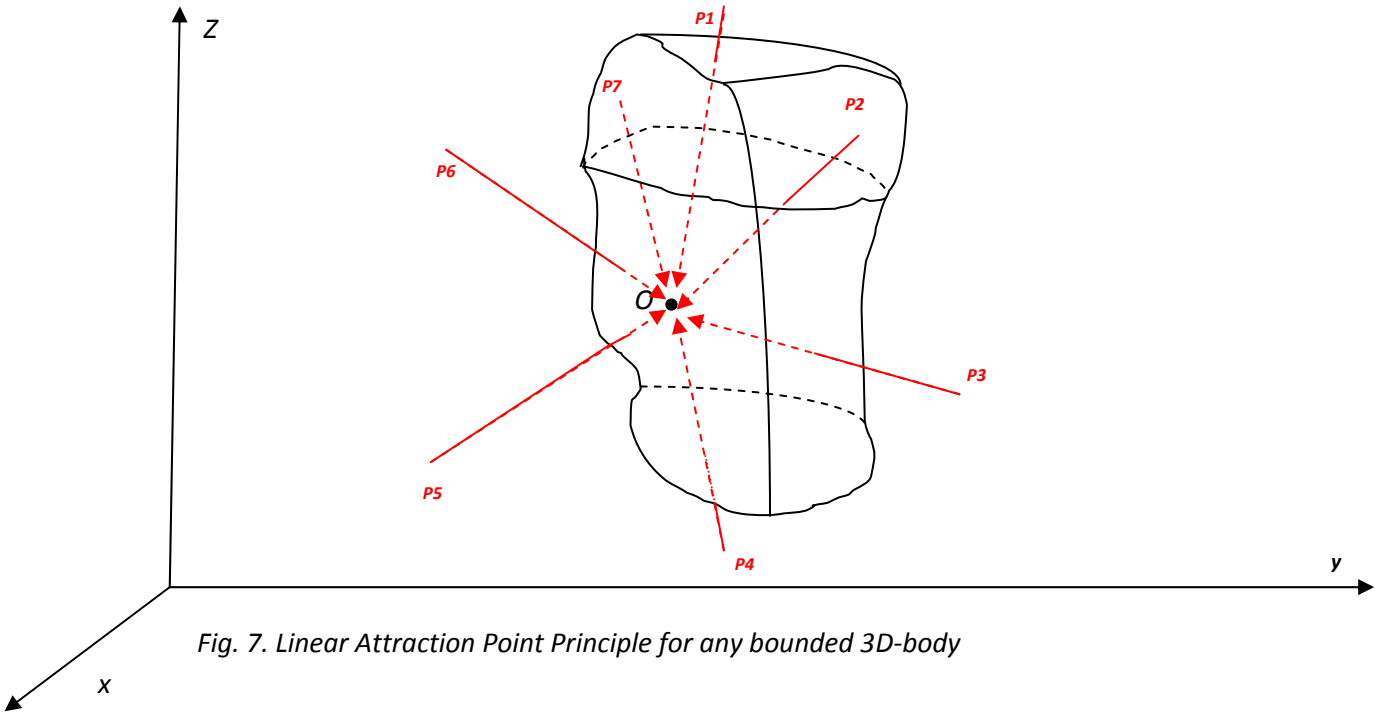

Fig. 7. Linear Attraction Point Principle for any bounded 3D-body

16. Non-Linear Attraction Point Principle in 3D-Space (and in n-D-Space).

There might be spaces where the attraction phenomena undergo not linearly by upon some specific non-linear curves. Let's see below such example for points P_i whose trajectories of attraction towards the optimal point follow some non-linear 3D-curves.

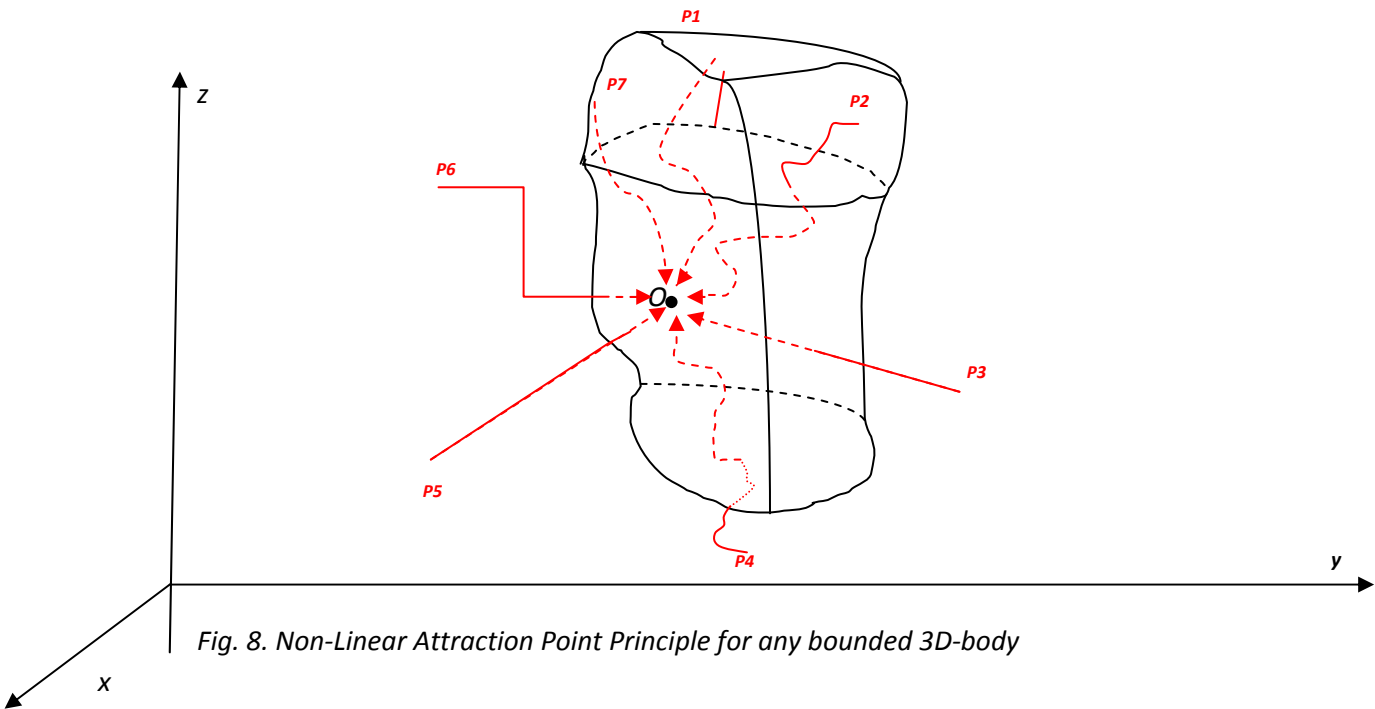

Fig. 8. Non-Linear Attraction Point Principle for any bounded 3D-body

17. n-D-Space.

In general, in a universe of discourse U , let's have an n -D-set S and a point P . Then the **Extension Linear n -D-Distance** between point P and set S , is:

$$\rho(P, S) = \begin{cases} -d(P, P'), & P' \in Fr(S), P \neq O, P \in |OP'|; \\ d(P, P'), & P' \in Fr(S), P \neq O, P' \in |OP|; \\ -\max_{M \in Fr(S)} d(P, M), & P = O. \end{cases}$$

where O is the optimal point (or linearly attraction point);

$d(P, P')$ means the classical linearly n -D-distance between two points P and P' ;

$Fr(S)$ means the frontier of set S ;

and $|OP'|$ means the line segment between the points O and P' (the extremity points O and P' included), therefore $P \in |OP'|$ means that P lies on the line OP' , in between the points O and P' .

For P coinciding with O , one defined the distance between the optimal point O and the set S as the negatively maximum distance (to be in concordance with the $1D$ -definition).

And the **Extension Non-Linear n -D-Distance** between point P and set S , is:

$$\rho_c(P, S) = \begin{cases} -d_c(P, P'), & P' \in Fr(S), P \neq O, P \in c(OP'); \\ d_c(P, P'), & P' \in Fr(S), P \neq O, P' \in c(OP); \\ -\max_{M \in Fr(S), M \in c(O)} d_c(P, M), & P = O. \end{cases}$$

where $\rho_c(P, S)$ means the extension distance as measured along the curve c ;

O is the optimal point (or non-linearly attraction point);

the points are attracting by the optimal point on trajectories described by an injective curve c ;

$d_c(P, P')$ means the non-linearly n -D-distance between two points P and P' , or the arclength of the curve c between the points P and P' ;

$Fr(S)$ means the frontier of set S ;

and $c(OP')$ means the curve segment between the points O and P' (the extremity points O and P' included), therefore $P \in c(OP')$ means that P lies on the curve c in between the points O and P' .

For P coinciding with O , one defined the distance between the optimal point O and the set S as the negatively maximum curvilinear distance (to be in concordance with the $1D$ -definition).

In general, in a universe of discourse U , let's have a nest of two n -D-sets, $S_1 \subset S_2$, with no common end points, and a point P .

Then the **Extension Linear Dependent n -D-Function** referring to the point $P(x_1, x_2, \dots, x_n)$ is:

$$K_{nD}(P) = \frac{\rho(P, S_2)}{\rho(P, S_2) - \rho(P, S_1)}$$

where $\rho(P, S_2)$ is the previous extension linear n-D-distance between the point P and the n -D-set S_2 .

And the **Extension Non-Linear Dependent n-D-Function** referring to point $P(x_1, x_2, \dots, x_n)$ along the curve c is:

$$K_{nD}(P) = \frac{\rho_c(P, S_2)}{\rho_c(P, S_2) - \rho_c(P, S_1)}$$

where $\rho_c(P, S_2)$ is the previous extension non-linear n-D-distance between the point P and the n -D-set S_2 along the curve c .

18. Remark 3.

Particular cases of curves c could be interesting to studying, for example if c are parabolas, or have elliptic forms, or arcs of circle, etc. Especially considering the geodesics would be for many practical applications.

Tremendous number of applications of Extenics could follow in all domains where attraction points would exist; these attraction points could be in physics (for example, the earth center is an attraction point), economics (attraction towards a specific product), sociology (for example attraction towards a specific life style), etc.

19. Location Value of a Point and the Dependent Function on a Single Finite Interval (on 1D-Space).

Suppose $S = \langle a, b \rangle$ is a finite interval. By the notation $\langle a, b \rangle$ one understands any type of interval: open (a, b) , closed $[a, b]$, or semi-open/semi-closed $(a, b]$ and $[a, b)$.

a) For any real point $x_0 \in R$, Qiao-Xing Li and Xing-Sen Li have considered

$$D(x_0, S) = a - b$$

as the location value of point $P(x_0)$ on the single finite interval $\langle a, b \rangle$.

Of course $D(x_0, S) = D(P, S) < 0$, since $a < b$.

As we can see, $a - b$ is the negative distance between the frontiers of the single finite interval S in the 1D-space.

b) Afterwards, the above authors defined for any real point $P(x_0)$, with $x_0 \in S$, the elementary dependent function on the single interval S in the following way:

$$k(x_0) = \frac{\rho(x_0, S)}{D(x_0, S)}$$

where $\rho(x_0, S)$ is the extension distance between point x_0 and the finite interval X in the $1D$ -space. Or we can re-write the above formula as:

$$k(P) = \frac{\rho(P, S)}{D(P, S)}.$$

20. Generalizations of the Location Value of a Point and the Dependent Function on a Single Finite Set on the n -D-Space.

In general, in a universe of discourse U , let's have an n -D-set S and a point $P \in U$.

- a) The **Generalized Location Value of Point P on the Single Finite Set S in n -D Space**, $D_{nD}(x_0, S)$, is the classical geometric distance (yet taken with a negative sign in front of it) between the set frontiers, distance taken on the line (or in general taken on the curve or geodesic) passing through the optimal point O and the given point P .
 In there are many distinct curves passing through both O and P in the Network of Attraction Curves, then one takes that curve for which one gets the maximum geometric distance (and one assigns a negative sign in front of this distance).
 We can also denote it as $D_{nD}(P, S)$.

Thus we have defined the **Generalized Extension Linear/Non-Linear n -D-Distance** between point P and set S , considering non-unique curves, as:

$$\rho_{nD}(P, S) = \begin{cases} -\max_{c \in NAC} \max_{P' \in Fr(S)} d(P, P'; c), & P \neq O, P \in c(OP'); \\ \max_{c \in NAC} \max_{P' \in Fr(S)} d(P, P'; c), & P \neq O, P' \in c(OP); \\ -\max_{c \in NAC} \max_{M \in Fr(S), M \in c(O)} d(P, M; c), & P=O. \end{cases}$$

where $\rho_{nD}(P, S)$ means the extension distance as measured along the curve c in the n -D space;
 O is the optimal point (or non-linearly attraction point);
 the points are attracting by the optimal point O on trajectories described by an injective curve c ;
 $d(P, P'; c)$ means the non-linearly n -D-distance between two points P and P' along the curve c , or the arclength of the curve c between the points P and P' ;
 $Fr(S)$ means the frontier of set S ;
 and $c(OP')$ means the curve segment between the points O and P' (the extremity points O and P' included), therefore $P \in c(OP')$ means that P lies on the curve c in between the points O and P' .
 For P coinciding with O , one defined the distance between the optimal point O and the set S as the negatively maximum curvilinear distance (to be in concordance with the $1D$ -definition).
 In the same way, if there are many curves, c in the Network of Attraction Curves, passing through both O and P , then one chooses that curve which maximizes the geometric distance.

We do these maximizations in order to be consistent with the case when the point P coincides with the optimal point O .

We now proceed to defining the **Generalized Dependent Function on a Single Finite Set S in n -D-Space of Point P** , considering non-unique curves:

$$k_{nD}(P) = \max_{c \in NAC} \frac{\rho_{nD}(P, S; c)}{D_{nD}(P, S; c)}$$

or using words: the Generalized Dependent Function on a Single Finite Set S of point P is the geometric distance between point P and the closest frontier on the line (or in general on the curve/geodesic c that connects P with the optimal point O) in the same side of the optimal point, divided by the distance [taken along the line (or in general on the curve/geodesic c that connects P with the optimal point O)] between the set frontiers.

If there are more curves passing through P and O , then one takes that curve which maximizes the value of $k_{nD}(P)$.

21. Examples of 2D-Dependent Function on a Single Finite Set.

Let's retake a previous example with two rectangles, $A_0M_0B_0N_0$ and AMB_N , whose sides are parallel to the axes of the Cartesian system of coordinates, such that they have no common end points, and $A_0M_0B_0N_0 \subset AMB_N$. The optimal point is O located in their center of symmetry.

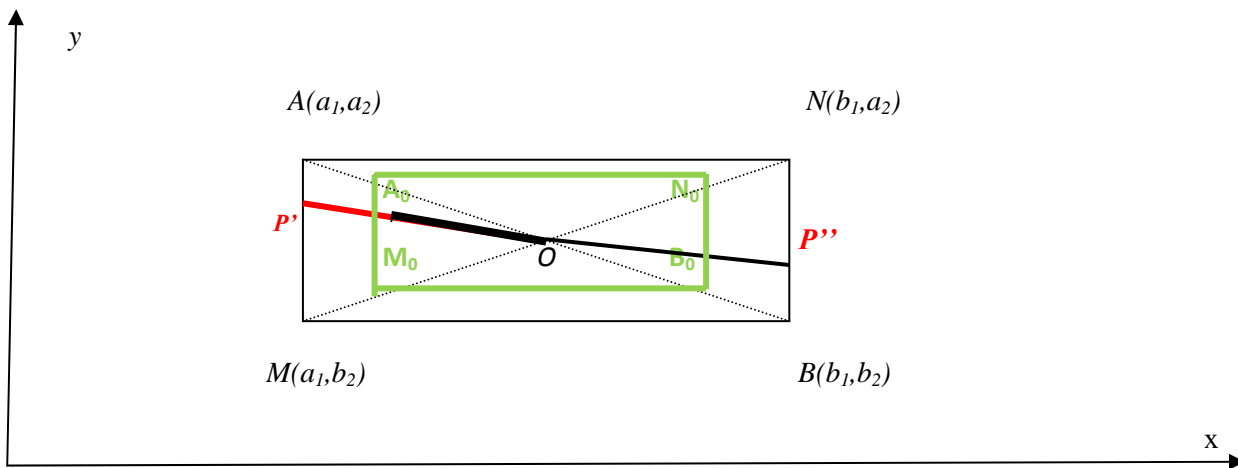

Fig. 9. The small rectangle shrinks until it vanishes.

If there is only a single finite set AMB_N , this means that the other set $A_0M_0B_0N_0$ (which is included in AMB_N) is shrinking little by little until vanishing, thus the $(0, 1)$ value of the dependent function of two nested sets increases until occupying the whole interior of the big set AMB_N :

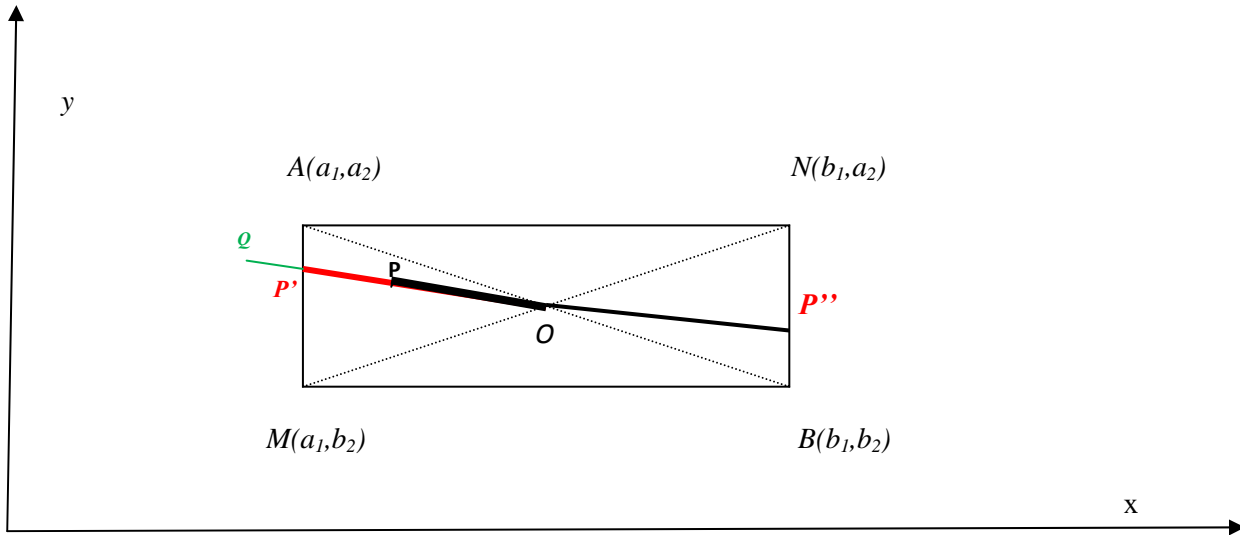

Fig. 10. The Dependent Function of a Point on a Single Rectangle.

The dependent function of interior point P with respect to the single rectangle $AMBN$ is:

$$k(P) = + \frac{|PP'|}{|P''P'|}$$

i.e. the distance between P and the closest frontier of the rectangle $\{ =|PP'| \}$, divided by the distance between the frontiers of the rectangle $\{ =|P''P'| \}$.

The dependent function of exterior point Q with respect to the single rectangle $AMBN$ is:

$$k(Q) = - \frac{|QP'|}{|P''P'|}$$

And the dependent function of frontier point P' with respect to the single rectangle $AMBN$ is:

$$k(P') = \frac{|P'P'|}{|P''P'|} = 0.$$

In this example we have considered only one curve of convergence for each point in the Network of Attraction Curves.

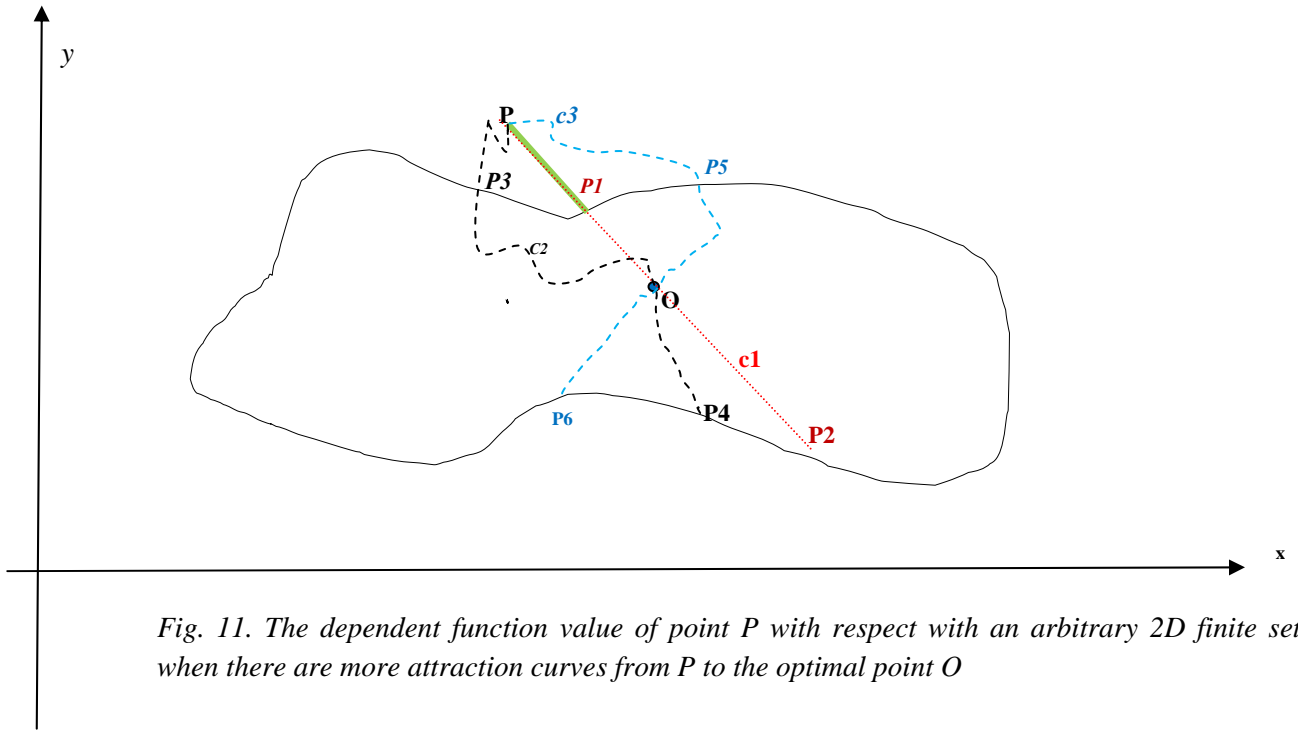

Fig. 11. The dependent function value of point P with respect with an arbitrary 2D finite set, when there are more attraction curves from P to the optimal point O

The dependent function value of point P is:

$$k(P) = -\max\left\{\frac{c1(PP1)}{c1(P1P2)} = \frac{|PP1|}{|P1P2|}, \frac{c2(PP3)}{c2(P3P4)}, \frac{c3(PP5)}{c3(P5P6)}\right\}$$

where $c1(PP1)$ means the arclength between the points P and $P1$ on the curve $c1$ (which happens in this case to be just a line segment), and similarly $c2(.,.)$ and $c3(.,.)$.

22. Example of 3D-Dependent Function on a Single Finite Set.

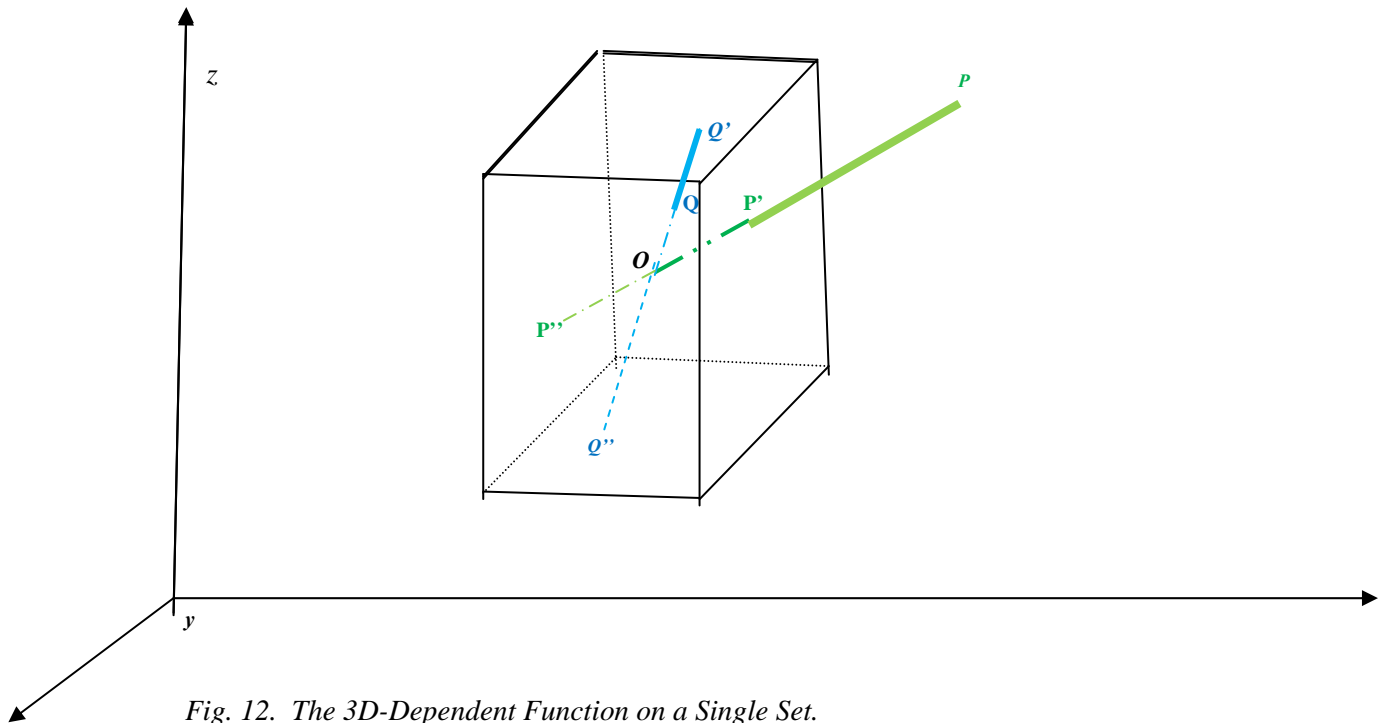

Fig. 12. The 3D-Dependent Function on a Single Set.

The dependent values on the single 3D-set is calculated for the following points:

$$k(P) = -\frac{|PP'|}{|P''P'|}, k(Q) = +\frac{|QQ'|}{|Q''Q'|}, k(P') = k(Q') = 0.$$

References:

Publications

1. Florentin Smarandache, *Generalizations of the Distance and Dependent Function in Extenics to 2D, 3D, and n-D*, "Global Journal of Science Frontier Research (GJSFR)" [USA, U.K., India], Vol. 12, Issue 8, pp. 47-60, 2012;
and in "Progress in Physics", University of New Mexico, USA, Vol. 3, pp. 54-61, 2012.
2. Florentin Smarandache and Victor Vlădăreanu, *Applications of Extenics to 2D-Space and 3D-Space*, Proceedings of the 6th International Conference on Software, Knowledge, Information Management and Applications (SKIMA 2012), Chengdu University, China, 9-11 September 2012.
3. Florentin Smarandache, *Extension Transformation Used in I Ching*, to appear in Octagon Mathematics Journal, Brasov, Romania, 2013.
4. Florentin Smarandache, Mihai Liviu Smarandache, *Generalizations in Extenics of the Location Value and Dependent Function from A Single Finite Interval to 2D, 3D, and n-D Spaces*, to appear in Octagon Mathematics Journal, Brasov, Romania, 2013.

Presentations at National and International Conferences or Institutes:

5. Florentin Smarandache, *Generalizations of the Distance and Dependent Function in Extenics to 2D, 3D, and n-D*, Guangdong University of Technology, Institute of Extenics Research and Innovation Methods, Guangzhou, China, June 4th, 2012.
6. Florentin Smarandache and Victor Vlădăreanu, *Applications of Extenics to 2D-Space and 3D-Space*, The 6th International Conference on Software, Knowledge, Information Management and Applications (SKIMA 2012), Chengdu University, China, 9-11 September 2012;
and at the Guangdong University of Technology, Institute of Extenics Research and Innovation Methods, Guangzhou, China, June 11th, 2012;
7. Florentin Smarandache and Ștefan Vladuțescu, *Extention Communication for Solving the Ontological Contradiction between Communication and Information*, Guangdong University of Technology, Institute of Extenics Research and Innovation Methods, Guangzhou, China, August 8th, 2012.
8. Florentin Smarandache, *Extension Transformation Used in I Ching*, Guangdong University of Technology, Institute of Extenics Research and Innovation Methods, Guangzhou, China, August 2nd, 2012.
9. Florentin Smarandache, *Generalization of the Dependent Function in Extenics for Nested Sets with Common Endpoints to 2D-Space, 3D-Space, and generally to n-D-Space*, Guangdong University of Technology, Institute of Extenics Research and Innovation Methods, Guangzhou, China, July 19nd, 2012.

Generalizations of the Distance and Dependent Function in Extenics to 2D, 3D, and n-D

Florentin Smarandache
University of New Mexico
Mathematics and Science Department
705 Gurey Ave.
Gallup, NM 87301, USA
E-mail: smarand@unm.edu

Abstract.

Dr. Cai Wen defined in his 1983 paper:

- the distance formula between a point x_0 and an one-dimensional (1D) interval $\langle a, b \rangle$;
- and the dependence function which gives the degree of dependence of a point with respect to a pair of included 1D-intervals.

His paper inspired us to generalize the Extension Set to two-dimensions, i.e. in plane of real numbers R^2 where one has a rectangle (instead of a segment of line), determined by two arbitrary points $A(a_1, a_2)$ and $B(b_1, b_2)$. And similarly in R^3 , where one has a prism determined by two arbitrary points $A(a_1, a_2, a_3)$ and $B(b_1, b_2, b_3)$. We geometrically define the linear and non-linear distance between a point and the 2D- and 3D-extension set and the dependent function for a nest of two included 2D- and 3D-extension sets. Linearly and non-linearly attraction point principles towards the optimal point are presented as well.

The same procedure can be then used considering, instead of a rectangle, any bounded 2D-surface and similarly any bounded 3D-solid, and any bounded n-D-body in R^n .

These generalizations are very important since the Extension Set is generalized from one-dimension to 2, 3 and even n-dimensions, therefore more classes of applications will result in consequence.

1. Introduction.

Extension Theory (or Extenics) was developed by Professor Cai Wen in 1983 by publishing a paper called "Extension Set and Non-Compatible Problems". Its goal is to solve contradictory problems and also nonconventional, nontraditional ideas in many fields.

Extenics is at the confluence of three disciplines: philosophy, mathematics, and engineering.

A contradictory problem is converted by a transformation function into a non-contradictory one.

The functions of transformation are: extension, decomposition, combination, etc.

Extenics has many practical applications in Management, Decision-Making, Strategic Planning, Methodology, Data Mining, Artificial Intelligence, Information Systems, Control Theory, etc.

Extenics is based on matter-element, affair-element, and relation-element.

2. Extension Distance in 1D-space.

Let's use the notation $\langle a, b \rangle$ for any kind of closed, open, or half-closed interval $\{ [a, b], (a, b), (a, b], [a, b) \}$.

Prof. Cai Wen has defined the extension distance between a point x_0 and a real interval $X = \langle a, b \rangle$, by

$$\rho(x_0, X) = \left| x_0 - \frac{a+b}{2} \right| - \frac{b-a}{2} \quad (1)$$

where in general $\rho : (\mathbb{R}, \mathbb{R}^2) \rightarrow (-\infty, +\infty)$. (2)

Algebraically studying this extension distance, we find that actually the range of it is:

$$\rho(x_0, X) \in \left[-\frac{b-a}{2}, +\infty \right) \quad (3)$$

or its minimum range value $-\frac{b-a}{2}$ depends on the interval X extremities a and b ,

and it occurs when the point x_0 coincides with the midpoint of the interval X , i.e. $x_0 = \frac{a+b}{2}$.

The closer is the interior point x_0 to the midpoint $\frac{a+b}{2}$ of the interval $\langle a, b \rangle$, the negatively larger is $\rho(x_0, X)$.

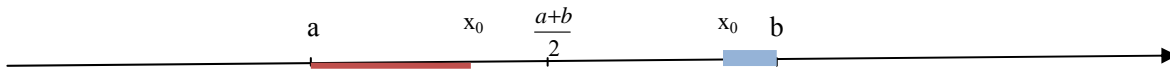

Fig. 1

In Fig. 1, for interior point x_0 between a and $\frac{a+b}{2}$, the extension distance $\rho(x_0, X) = a - x_0 =$ *the negative length of the brown line segment* [left side]. Whereas for interior point x_0 between $\frac{a+b}{2}$ and b , the extension distance $\rho(x_0, X) = x_0 - b =$ *the negative length of the blue line segment* [right side].

Similarly, the further is exterior point x_0 with respect to the closest extremity of the interval $\langle a, b \rangle$ to it (i.e. to either a or b), the positively larger is $\rho(x_0, X)$.

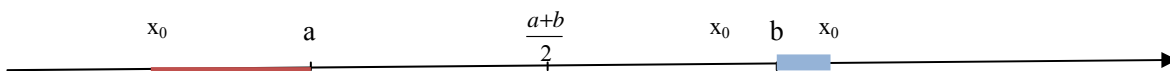

Fig. 2

In Fig. 2, for exterior point $x_0 < a$, the extension distance $\rho(x_0, X) = a - x_0 = \text{the positive length of the brown line segment [left side]}$. Whereas for exterior point $x_0 > b$, the extension distance $\rho(x_0, X) = x_0 - b = \text{the positive length of the blue line segment [right side]}$.

3. Principle of the Extension 1D-Distance.

Geometrically studying this extension distance, we find the following principle that Prof. Cai has used in 1983 defining it:

$\rho(x_0, X)$ = the geometric distance between the point x_0 and the closest extremity point of the interval $\langle a, b \rangle$ to it (going in the direction that connects x_0 with the optimal point), distance taken as negative if $x_0 \in \langle a, b \rangle$, and as positive if $x_0 \notin \langle a, b \rangle$.

This principle is very important in order to generalize the extension distance from 1D to 2D (two-dimensional real space), 3D (three-dimensional real space), and n -D (n -dimensional real space).

The extremity points of interval $\langle a, b \rangle$ are the point a and b , which are also the boundary (frontier) of the interval $\langle a, b \rangle$.

4. Dependent Function in 1D-Space.

Prof. Cai Wen defined in 1983 in 1D the Dependent Function $K(y)$.

If one considers two intervals X_0 and X , that have no common end point, and $X_0 \subset X$, then:

$$K(y) = \frac{\rho(y, X)}{\rho(y, X) - \rho(y, X_0)}. \quad (4)$$

Since $K(y)$ was constructed in 1D in terms of the extension distance $\rho(.,.)$, we simply generalize it to higher dimensions by replacing $\rho(.,.)$ with the generalized $\rho(.,.)$ in a higher dimension.

5. Extension Distance in 2D-Space.

Instead of considering a segment of line AB representing the interval $\langle a, b \rangle$ in 1R, we consider a rectangle $AMBN$ representing all points of its surface in 2D. Similarly as for 1D-space, the rectangle in 2D-space may be closed (i.e. all points lying on its frontier belong to it), open (i.e. no point lying on its frontier belong to it), or partially closed (i.e. some points lying on its frontier belong to it, while other points lying on its frontier do not belong to it).

Let's consider two arbitrary points $A(a_1, a_2)$ and $B(b_1, b_2)$. Through the points A and B one draws parallels to the axes of the Cartesian system XY and one thus one forms a rectangle $AMBN$ whose one of the diagonals is just AB .

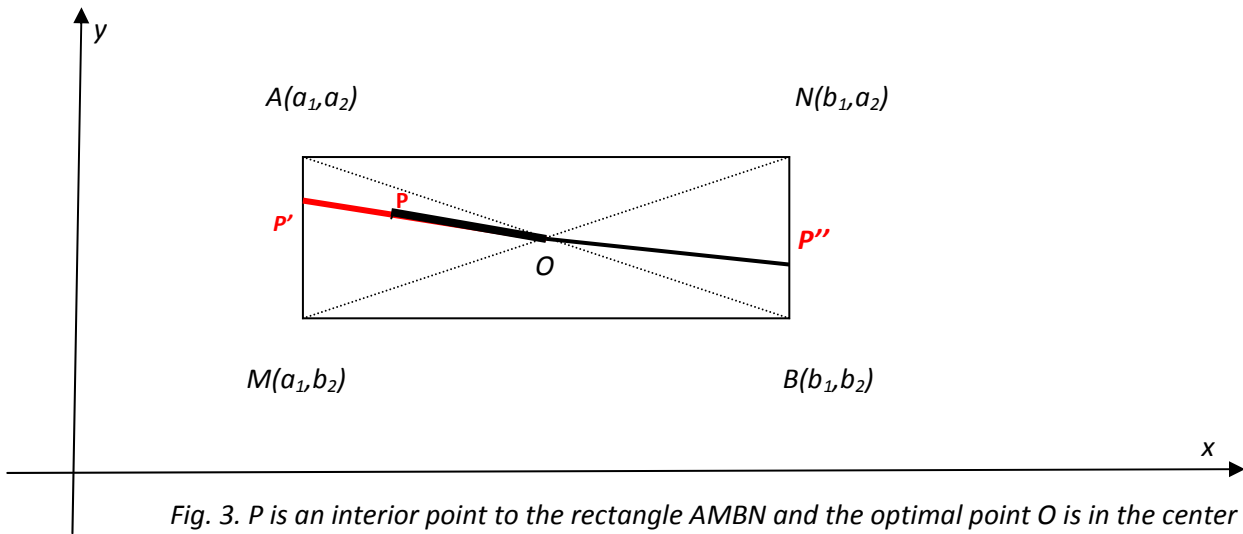

Fig. 3. P is an interior point to the rectangle $AMBN$ and the optimal point O is in the center of symmetry of the rectangle

Let's note by O the midpoint of the diagonal AB , but O is also the center of symmetry (intersection of the diagonals) of the rectangle $AMBN$.

Then one computes the distance between a point $P(x_0, y_0)$ and the rectangle $AMBN$.

One can do that following the same principle as Dr. Cai Wen did:

- compute the distance in $2D$ (two dimensions) between the point P and the center O of the rectangle (intersection of rectangle's diagonals);
- next compute the distance between the point P and the closest point (let's note it by P') to it on the frontier (the rectangle's four edges) of the rectangle $AMBN$;

this step can be done in the following way:

considering P' as the intersection point between the line PO and the frontier of the rectangle, and taken among the intersection points that point P' which is the closest to P ; this case is entirely consistent with Dr. Cai's approach in the sense that when reducing from a $2D$ -space problem to two $1D$ -space problems, one exactly gets his result.

The Extension $2D$ -Distance, for $P \neq O$, will be:

$$\rho((x_0, y_0), AMBN) = d(\text{point } P, \text{rectangle } AMBN) = |PO| - |P'O| = \pm |PP'| \quad (5)$$

- i) which is equal to the negative length of the red segment $|PP'|$ in Fig. 3 when P is interior to the rectangle $AMBN$;
- ii) or equal to zero when P lies on the frontier of the rectangle $AMBN$ (i.e. on edges AM , MB , BN , or NA) since P coincides with P' ;

iii) or equal to the positive length of the blue segment $|PP'|$ in Fig. 4 when P is exterior to the rectangle $AMBN$.

where $|PO|$ means the classical 2D-distance between the point P and O , and similarly for $|P'O|$ and $|PP'|$.

The Extension 2D-Distance, for the optimal point (i.e. $P=O$), will be
 $\rho(O, AMBN) = d(\text{point } O, \text{rectangle } AMBN) = - \max d(\text{point } O, \text{point } M \text{ on the frontier of } AMBN).$ (6)

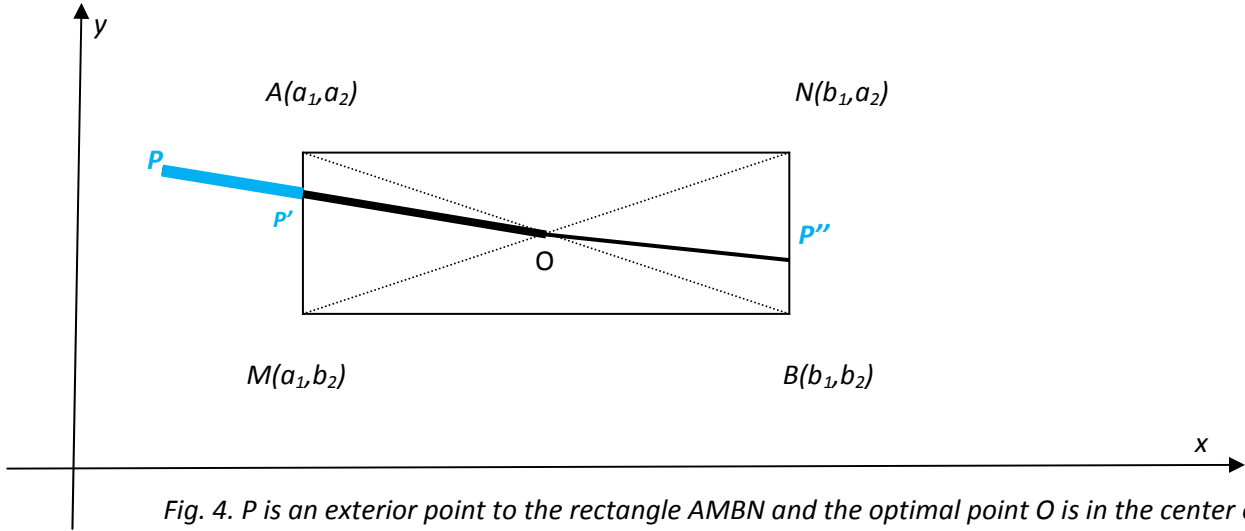

Fig. 4. P is an exterior point to the rectangle $AMBN$ and the optimal point O is in the center of symmetry of the rectangle

The last step is to devise the Dependent Function in 2D-space similarly as Dr. Cai's defined the dependent function in 1D.

The midpoint (or center of symmetry) O has the coordinates $O(\frac{a_1 + b_1}{2}, \frac{a_2 + b_2}{2})$. (7)

Let's compute the $|PO| - |P'O|$. (8)

In this case, we extend the line OP to intersect the frontier of the rectangle $AMBN$. P' is closer to P than P'' , therefore we consider P' .

The equation of the line PO , that of course passes through the points $P(x_0, y_0)$ and $O(\frac{a_1 + b_1}{2}, \frac{a_2 + b_2}{2})$,

is:

$$y - y_0 = \frac{\frac{a_2 + b_2}{2} - y_0}{\frac{a_1 + b_1}{2} - x_0} (x - x_0) \quad (9)$$

Since the x -coordinate of point P' is a_1 because P' lies on the rectangle's edge AM , one gets the y -coordinate of point P' by a simple substitution of $x_{P'} = a_1$ into the above equality:

$$y_{P'} = y_0 + \frac{a_2 + b_2 - 2y_0}{a_1 + b_1 - 2x_0} (a_1 - x_0). \quad (10)$$

Therefore P' has the coordinates $P'(x_{P'} = a_1, y_{P'} = y_0 + \frac{a_2 + b_2 - 2y_0}{a_1 + b_1 - 2x_0} (a_1 - x_0))$. (11)

The distance $d(P, O) = |PO| = \sqrt{(x_0 - \frac{a_1 + b_1}{2})^2 + (y_0 - \frac{a_2 + b_2}{2})^2}$ (12)

while the distance

$$d(P', O) = |P'O| = \sqrt{(a_1 - \frac{a_1 + b_1}{2})^2 + (y_{P'} - \frac{a_2 + b_2}{2})^2} = \sqrt{(\frac{a_1 - b_1}{2})^2 + (y_{P'} - \frac{a_2 + b_2}{2})^2} \quad (13)$$

Also, the distance $d(P, P') = |PP'| = \sqrt{(a_1 - x_0)^2 + (y_{P'} - y_0)^2}$. (14)

Whence the Extension 2D-Distance formula:

$$\rho((x_0, y_0), AMBM) = d(P(x_0, y_0), A(a_1, a_2)MB(b_1, b_2)N) = |PO| - |P'O| \quad (15)$$

$$= \sqrt{(x_0 - \frac{a_1 + b_1}{2})^2 + (y_0 - \frac{a_2 + b_2}{2})^2} - \sqrt{(\frac{a_1 - b_1}{2})^2 + (y_{P'} - \frac{a_2 + b_2}{2})^2} \quad (16)$$

$$= \pm |PP'| \quad (17)$$

$$= \pm \sqrt{(a_1 - x_0)^2 + (y_{P'} - y_0)^2} \quad (18)$$

where $y_{P'} = y_0 + \frac{a_2 + b_2 - 2y_0}{a_1 + b_1 - 2x_0} (a_1 - x_0)$. (19)

6. Properties.

As for 1D-distance, the following properties hold in 2D:

6.1. Property 1.

a) $(x, y) \in \text{Int}(AMBN)$ iff $\rho((x, y), AMBN) < 0$, where $\text{Int}(AMBN)$ means interior of $AMBN$;

- b) $(x,y) \in \text{Fr}(AMBN)$ iff $\rho((x,y), AMBN) = 0$, where $\text{Fr}(AMBN)$ means frontier of $AMBN$;
c) $(x,y) \notin AMBN$ iff $\rho((x,y), AMBN) > 0$.

6.2. Property 2.

Let $A_0M_0B_0N_0$ and $AMBN$ be two rectangles whose sides are parallel to the axes of the Cartesian system of coordinates, such that they have no common end points, and $A_0M_0B_0N_0 \subset AMBN$. We assume they have the same optimal points $O_1 \equiv O_2 \equiv O$ located in the center of symmetry of the two rectangles.

Then for any point $(x,y) \in \mathbb{R}^2$ one has $\rho((x,y), A_0M_0B_0N_0) \geq \rho((x,y), AMBN)$.

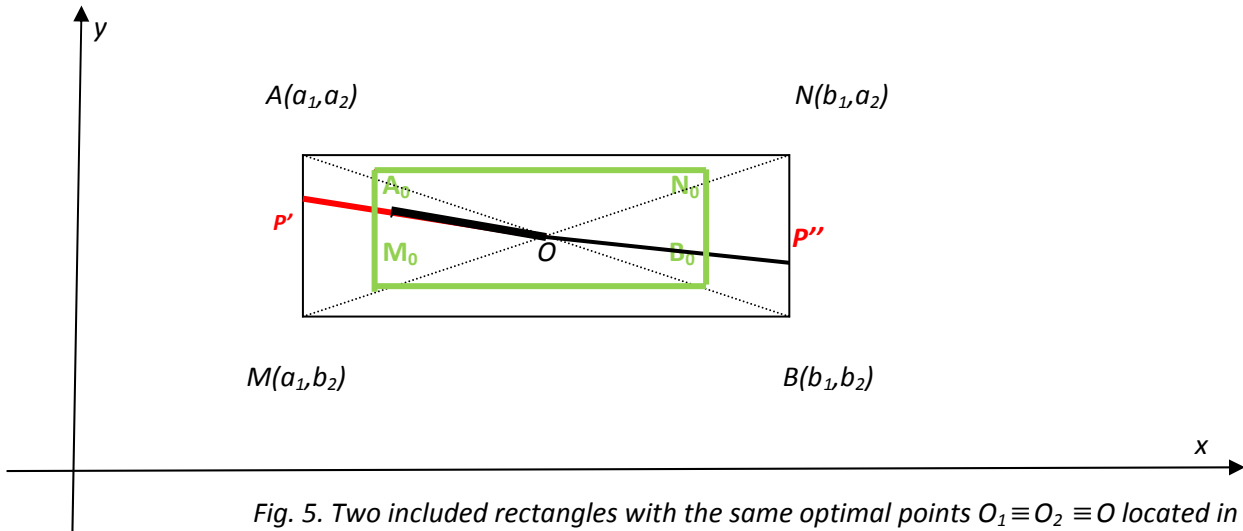

Fig. 5. Two included rectangles with the same optimal points $O_1 \equiv O_2 \equiv O$ located in their common center of symmetry

7. Dependent 2D-Function.

Let $A_0M_0B_0N_0$ and $AMBN$ be two rectangles whose sides are parallel to the axes of the Cartesian system of coordinates, such that they have no common end points, and $A_0M_0B_0N_0 \subset AMBN$.

The **Dependent 2D-Function** formula is:

$$K_{2D}(x,y) = \frac{\rho((x,y), AMBN)}{\rho((x,y), AMBN) - \rho((x,y), A_0M_0B_0N_0)} \quad (20)$$

7.1. Property 3.

Again, similarly to the Dependent Function in $1D$ -space, one has:

- a) If $(x,y) \in \text{Int}(A_0M_0B_0N_0)$, then $K_{2D}(x,y) > 1$;

- b) If $(x,y) \in Fr(A_0M_0B_0N_0)$, then $K_{2D}(x,y) = 1$;
- c) If $(x,y) \in Int(AMBN - A_0M_0B_0N_0)$, then $0 < K_{2D}(x,y) < 1$;
- d) If $(x,y) \in Fr(AMBN)$, then $K_{2D}(x,y) = 0$;
- e) If $(x,y) \notin AMBN$, then $K_{2D}(x,y) < 0$.

8. General Case in 2D-Space.

One can replace the rectangles by any finite surfaces, bounded by closed curves in 2D-space, and one can consider any optimal point O (not necessarily the symmetry center). Again, we assume the optimal points are the same for this nest of two surfaces.

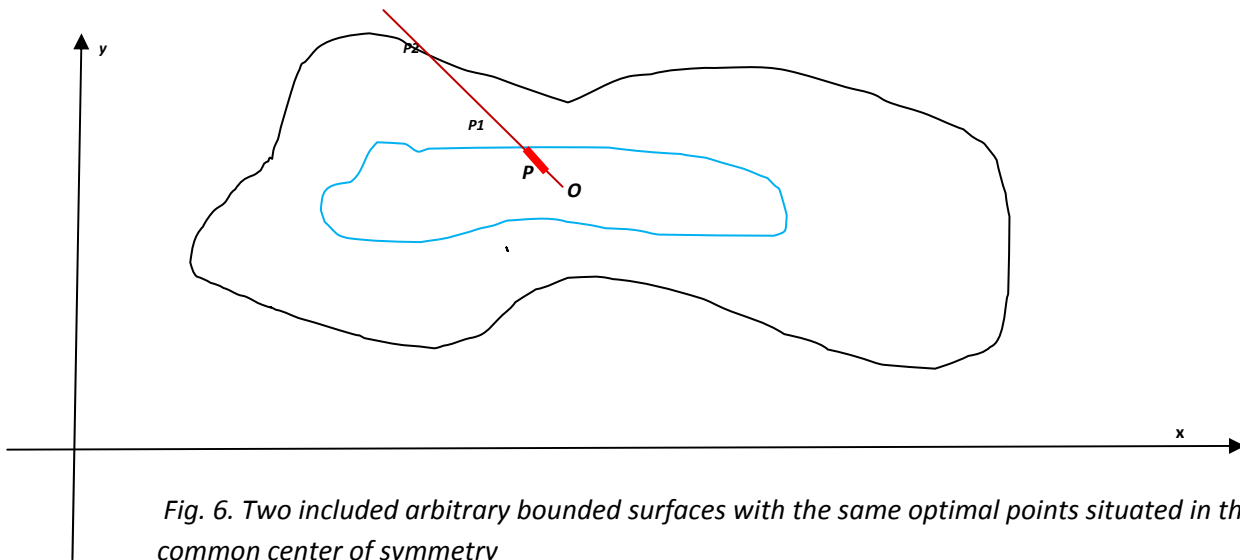

Fig. 6. Two included arbitrary bounded surfaces with the same optimal points situated in their common center of symmetry

9. Linear Attraction Point Principle.

We introduce the Attraction Point Principle, which is the following:

Let S be a given set in the universe of discourse U , and the optimal point $O \in S$. Then each point $P(x_1, x_2, \dots, x_n)$ from the universe of discourse tends towards, or is attracted by, the optimal point O , because the optimal point O is an ideal of each point.

That's why one computes the extension n -D-distance between the point P and the set S as $\rho(x_1, x_2, \dots, x_n, S)$ on the direction determined by the point P and the optimal point O , or on the line PO , i.e.:

- a) $\rho(x_1, x_2, \dots, x_n, S) =$ the *negative distance* between P and the set frontier, if P is inside the set S ;

- b) $\rho(x_1, x_2, \dots, x_n, S) = 0$, if P lies on the frontier of the set S ;
- c) $\rho(x_1, x_2, \dots, x_n, S) =$ the *positive distance* between P and the set frontier, if P is outside the set.

It is a kind of convergence/attraction of each point towards the optimal point. There are classes of examples where such attraction point principle works.

If this principle is good in all cases, then there is no need to take into consideration the center of symmetry of the set S , since for example if we have a 2D piece which has heterogeneous material density, then its center of weight (barycenter) is different from the center of symmetry.

Let's see below such example in the 2D-space:

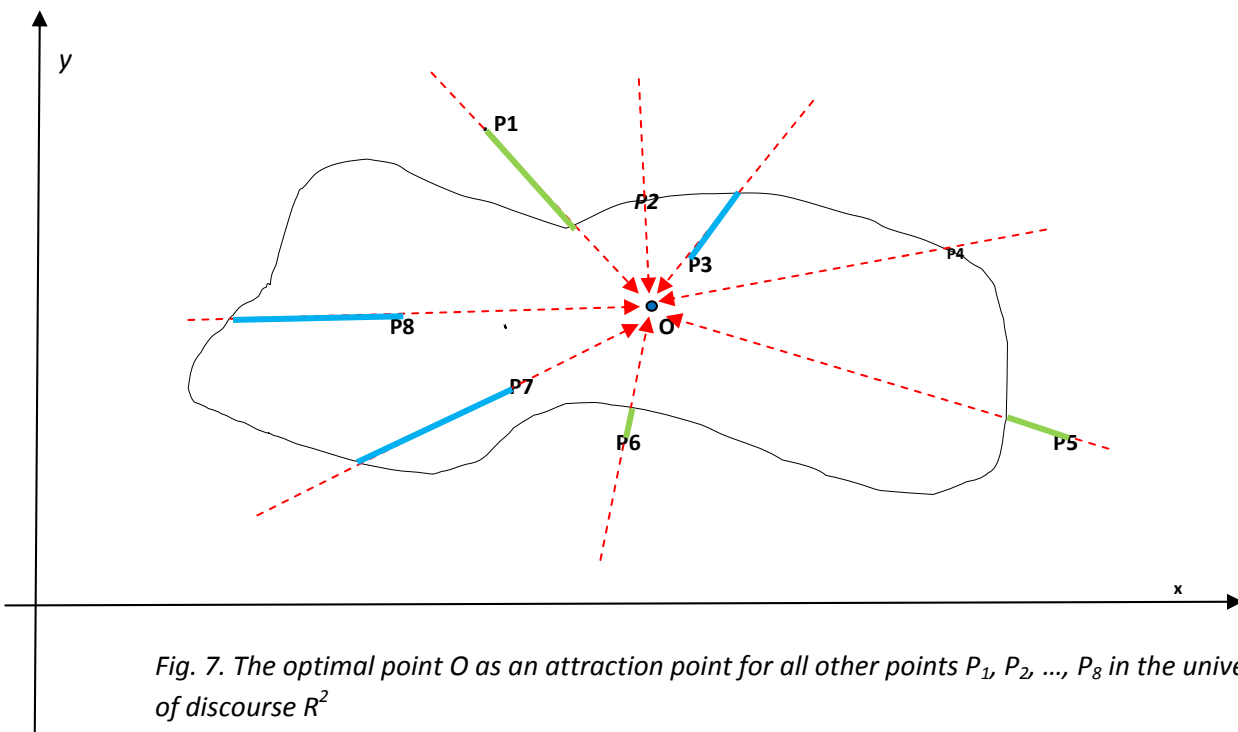

Fig. 7. The optimal point O as an attraction point for all other points P_1, P_2, \dots, P_8 in the universe of discourse R^2

10. Remark 1.

Another possible way, for computing the distance between the point P and the closest point P' to it on the frontier (the rectangle's four edges) of the rectangle $AMBN$, would be by drawing a perpendicular (or a geodesic) from P onto the closest rectangle's edge, and denoting by P' the intersection between the perpendicular (geodesic) and the rectangle's edge.

And similarly if one has an arbitrary set S in the 2D-space, bounded by a closed curve. One computes

$$d(P, S) = \inf_{Q \in S} |PQ| \tag{21}$$

as in the classical mathematics.

11. Extension Distance in 3D-Space.

We further generalize to 3D-space the Extension Set and the Dependent Function.

Assume we have two points $A(a_1, a_2, a_3)$ and $B(b_1, b_2, b_3)$ in 3D. Drawing through A and B parallel planes to the planes' axes (XY, XZ, YZ) in the Cartesian system XYZ we get a prism $AM_1M_2M_3BN_1N_2N_3$ (with eight vertices) whose one of the transversal diagonals is just the line segment AB . Let's note by O the midpoint of the transverse diagonal AB , but O is also the center of symmetry of the prism.

Therefore, from the line segment AB in 1D-space, to a rectangle $AMBN$ in 2D-space, and now to a prism $AM_1M_2M_3BN_1N_2N_3$ in 3D-space. Similarly to 1D- and 2D-space, the prism may be closed (i.e. all points lying on its frontier belong to it), open (i.e. no point lying on its frontier belong to it), or partially closed (i.e. some points lying on its frontier belong to it, while other points lying on its frontier do not belong to it).

Then one computes the distance between a point $P(x_0, y_0, z_0)$ and the prism $AM_1M_2M_3BN_1N_2N_3$.

One can do that following the same principle as Dr. Cai's:

- compute the distance in 3D (two dimensions) between the point P and the center O of the prism (intersection of prism's transverse diagonals);
- next compute the distance between the point P and the closest point (let's note it by P') to it on the frontier (the prism's lateral surface) of the prism $AM_1M_2M_3BN_1N_2N_3$;

considering P' as the intersection point between the line OP and the frontier of the prism, and taken among the intersection points that point P' which is the closest to P ; this case is entirely consistent with Dr. Cai's approach in the sense that when reducing from 3D-space to 1D-space one gets exactly Dr. Cai's result;

- the Extension 3D-Distance will be: $d(P, AM_1M_2M_3BN_1N_2N_3) = |PO| - |P'O| = \pm |PP'|$,

where $|PO|$ means the classical distance in 3D-space between the point P and O , and similarly for $|P'O|$ and $|PP'|$.

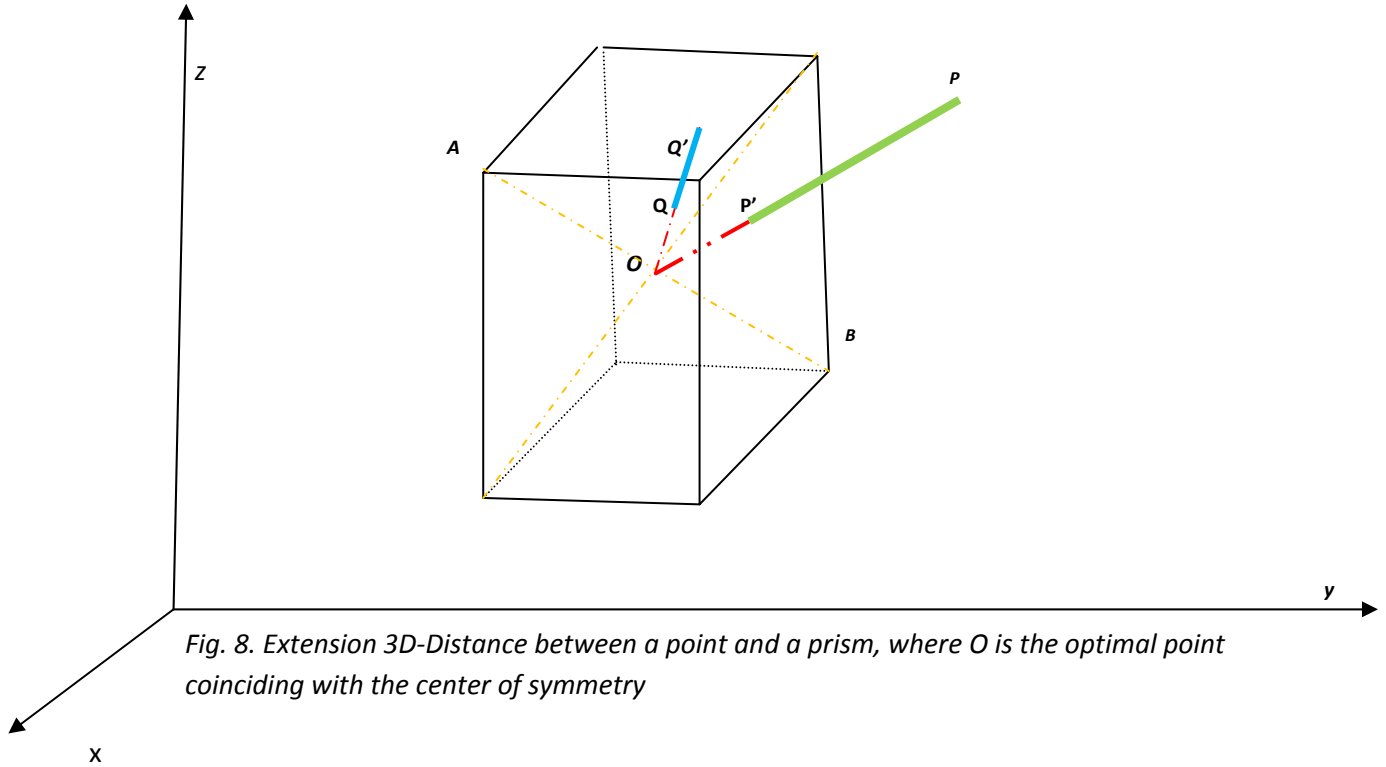

Fig. 8. Extension 3D-Distance between a point and a prism, where O is the optimal point coinciding with the center of symmetry

12. Property 4.

- a) $(x, y, z) \in \text{Int}(AM_1M_2M_3BN_1N_2N_3)$ iff $\rho((x, y, z), AM_1M_2M_3BN_1N_2N_3) < 0$, where $\text{Int}(AM_1M_2M_3BN_1N_2N_3)$ means interior of $AM_1M_2M_3BN_1N_2N_3$;
- b) $(x, y, z) \in \text{Fr}(AM_1M_2M_3BN_1N_2N_3)$ iff $\rho((x, y, z), AM_1M_2M_3BN_1N_2N_3) = 0$, where $\text{Fr}(AM_1M_2M_3BN_1N_2N_3)$ means frontier of $AM_1M_2M_3BN_1N_2N_3$;
- c) $(x, y, z) \notin AM_1M_2M_3BN_1N_2N_3$ iff $\rho((x, y, z), AM_1M_2M_3BN_1N_2N_3) > 0$.

13. Property 5.

Let $A_0M_01M_02M_03B_0N_01N_02N_03$ and $AM_1M_2M_3BN_1N_2N_3$ be two prisms whose sides are parallel to the axes of the Cartesian system of coordinates, such that they have no common end points, and $A_0M_01M_02M_03B_0N_01N_02N_03 \subset AM_1M_2M_3BN_1N_2N_3$. We assume they have the same optimal points $O_1 \equiv O_2 \equiv O$ located in the center of symmetry of the two prisms.

Then for any point $(x, y, z) \in R^3$ one has

$$\rho((x, y, z), A_0M_{01}M_{02}M_{03}B_0N_{01}N_{02}N_{03}) \geq \rho((x, y, z), AM_1M_2M_3BN_1N_2N_3).$$

14. The Dependent 3D-Function.

The last step is to devise the Dependent Function in 3D-space similarly to Dr. Cai's definition of the dependent function in 1D-space.

Let $A_0M_{01}M_{02}M_{03}B_0N_{01}N_{02}N_{03}$ and $AM_1M_2M_3BN_1N_2N_3$ be two prisms whose faces are parallel to the axes of the Cartesian system of coordinates XYZ , such that they have no common end points, such that $A_0M_{01}M_{02}M_{03}B_0N_{01}N_{02}N_{03} \subset AM_1M_2M_3BN_1N_2N_3$. We assume they have the same optimal points $O_1 \equiv O_2 \equiv O$ located in the center of symmetry of these two prisms.

The **Dependent 3D-Function** formula is:

$$K_{3D}(x, y, z) = \frac{\rho((x, y, z), AM_1M_2M_3BN_1N_2N_3)}{\rho((x, y, z), AM_1M_2M_3BN_1N_2N_3) - \rho((x, y, z), A_0M_{01}M_{02}M_{03}BN_{01}N_{02}N_{03})} \quad (22)$$

15. Property 6.

Again, similarly to the Dependent Function in 1D- and 2D-spaces, one has:

- a) If $(x, y, z) \in \text{Int}(A_0M_{01}M_{02}M_{03}B_0N_{01}N_{02}N_{03})$, then $K_{3D}(x, y, z) > 1$;
- b) If $(x, y, z) \in \text{Fr}(A_0M_{01}M_{02}M_{03}B_0N_{01}N_{02}N_{03})$, then $K_{3D}(x, y, z) = 1$;
- c) If $(x, y, z) \in \text{Int}(AM_1M_2M_3BN_1N_2N_3 - A_0M_{01}M_{02}M_{03}B_0N_{01}N_{02}N_{03})$, then $0 < K_{3D}(x, y, z) < 1$;
- d) If $(x, y, z) \in \text{Fr}(AM_1M_2M_3BN_1N_2N_3)$, then $K_{3D}(x, y, z) = 0$;
- e) If $(x, y, z) \notin AM_1M_2M_3BN_1N_2N_3$, then $K_{3D}(x, y, z) < 0$.

16. General Case in 3D-Space.

One can replace the prisms by any finite 3D-bodies, bounded by closed surfaces, and one considers any optimal point O (not necessarily the centers of surfaces' symmetry). Again, we assume the optimal points are the same for this nest of two 3D-bodies.

17. Remark 2.

Another possible way, for computing the distance between the point P and the closest point P' to it on the frontier (lateral surface) of the prism $AM_1M_2M_3BN_1N_2N_3$ is by drawing a perpendicular (or a geodesic) from P onto the closest prism's face, and denoting by P' the intersection between the perpendicular (geodesic) and the prism's face.

And similarly if one has an arbitrary finite body B in the 3D-space, bounded by surfaces. One computes as in classical mathematics:

$$d(P, B) = \inf_{Q \in B} |PQ|$$

(23)

18. Linear Attraction Point Principle in 3D-Space.

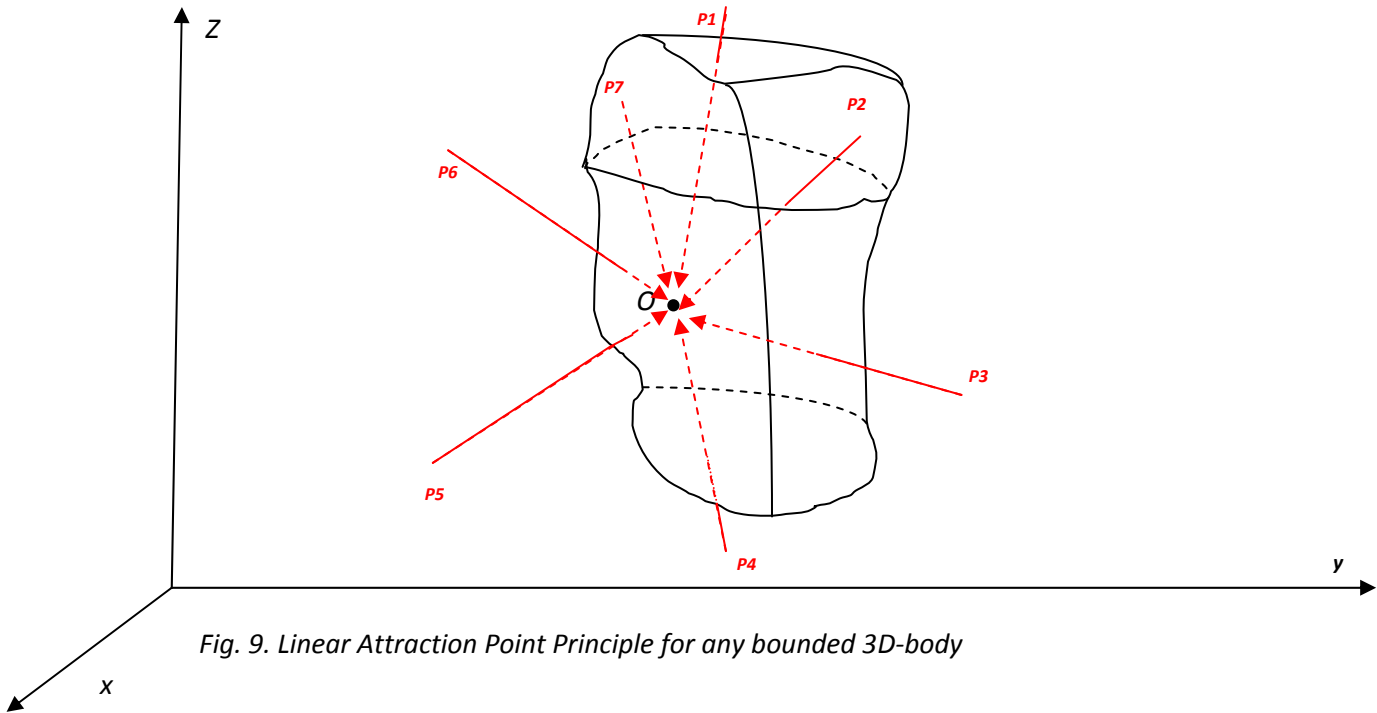

Fig. 9. Linear Attraction Point Principle for any bounded 3D-body

19. Non-Linear Attraction Point Principle in 3D-Space (and in n-D-Space).

There might be spaces where the attraction phenomena undergo not linearly by upon some specific non-linear curves. Let's see below such example for points P_i whose trajectories of attraction towards the optimal point follow some non-linear 3D-curves.

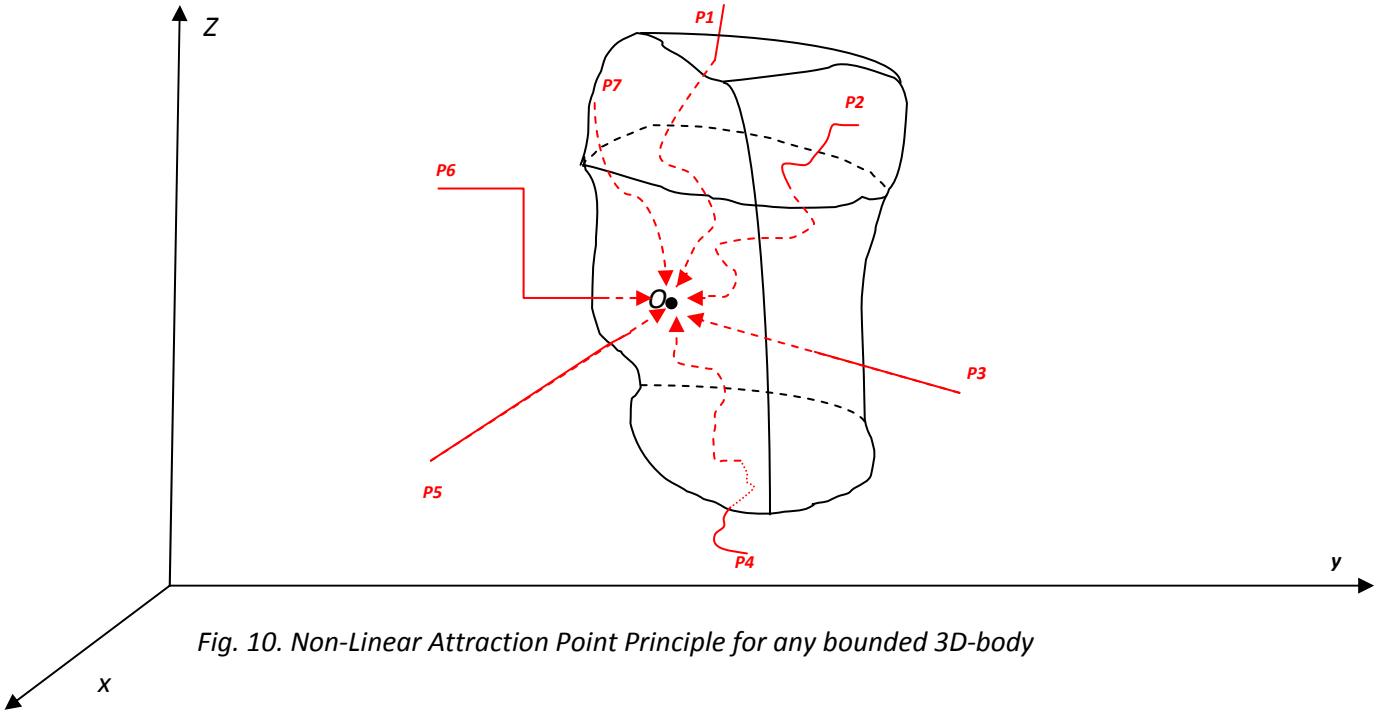

Fig. 10. Non-Linear Attraction Point Principle for any bounded 3D-body

20. n-D-Space.

In general, in a universe of discourse U , let's have an n -D-set S and a point P . Then the **Extension Linear n -D-Distance** between point P and set S , is:

$$\rho(P, S) = \begin{cases} -d(P, P'), & P \neq O, P \in |OP'|; \\ d(P, P'), & P \neq O, P' \in |OP|; \\ -\max_{M \in Fr(S)} d(P, M), & P = O. \end{cases} \quad (24)$$

where O is the optimal point (or linearly attraction point);

$d(P, P')$ means the classical linearly n -D-distance between two points P and P' ;

$Fr(S)$ means the frontier of set S ;

and $|OP'|$ means the line segment between the points O and P' (the extremity points O and P' included), therefore $P \in |OP'|$ means that P lies on the line OP' , in between the points O and P' .

For P coinciding with O , one defined the distance between the optimal point O and the set S as the negatively maximum distance (to be in concordance with the $1D$ -definition).

And the **Extension Non-Linear n -D-Distance** between point P and set S , is:

$$\rho_c(P, S) = \begin{cases} -d_c(P, P'), & P \neq O, P \in c(OP'); \\ d_c(P, P'), & P \neq O, P' \in c(OP); \\ -\max_{M \in Fr(S), M \in c(O)} d_c(P, M), & P = O. \end{cases} \quad (25)$$

where $\rho_c(P, S)$ means the extension distance as measured along the curve c ;

O is the optimal point (or non-linearly attraction point);

the points are attracting by the optimal point on trajectories described by an injective curve c ;

$d_c(P, P')$ means the non-linearly n -D-distance between two points P and P' , or the arclength of the curve c between the points P and P' ;

$Fr(S)$ means the frontier of set S ;

and $c(OP')$ means the curve segment between the points O and P' (the extremity points O and P' included), therefore $P \in c(OP')$ means that P lies on the curve c in between the points O and P' .

For P coinciding with O , one defined the distance between the optimal point O and the set S as the negatively maximum curvilinear distance (to be in concordance with the $1D$ -definition).

In general, in a universe of discourse U , let's have a nest of two n -D-sets, $S_1 \subset S_2$, with no common end points, and a point P .

Then the **Extension Linear Dependent n -D-Function** referring to the point $P(x_1, x_2, \dots, x_n)$ is:

$$K_{nD}(P) = \frac{\rho(P, S_2)}{\rho(P, S_2) - \rho(P, S_1)} \quad (26)$$

where $\rho(P, S_2)$ is the previous extension linear n -D-distance between the point P and the n -D-set S_2 .

And the **Extension Non-Linear Dependent n -D-Function** referring to point $P(x_1, x_2, \dots, x_n)$ along the curve c is:

$$K_{nD}(P) = \frac{\rho_c(P, S_2)}{\rho_c(P, S_2) - \rho_c(P, S_1)} \quad (27)$$

where $\rho_c(P, S_2)$ is the previous extension non-linear n -D-distance between the point P and the n -D-set S_2 along the curve c .

21. Remark 3.

Particular cases of curves c could be interesting to studying, for example if c are parabolas, or have elliptic forms, or arcs of circle, etc. Especially considering the geodesics would be for many practical applications.

Tremendous number of applications of Extenics could follow in all domains where attraction points would exist; these attraction points could be in physics (for example, the earth center is an attraction point), economics (attraction towards a specific product), sociology (for example attraction towards a specific life style), etc.

22. Conclusion.

In this paper we introduced the **Linear and Non-Linear Attraction Point Principle**, which is the following:

Let \mathcal{S} be an arbitrary set in the universe of discourse U of any dimension, and the optimal point $O \in \mathcal{S}$. Then each point $P(x_1, x_2, \dots, x_n)$, $n \geq 1$, from the universe of discourse (linearly or non-linearly) tends towards, or is attracted by, the optimal point O , because the optimal point O is an ideal of each point.

It is a kind of convergence/attraction of each point towards the optimal point. There are classes of examples and applications where such attraction point principle may apply.

If this principle is good in all cases, then there is no need to take into consideration the center of symmetry of the set \mathcal{S} , since for example if we have a 2D factory piece which has heterogeneous material density, then its center of weight (barycenter) is different from the center of symmetry.

Then we generalized in the track of Cai Wen's idea the extension 1D-set to an extension n -D-set, and defined the Linear (or Non-Linear) **Extension n -D-Distance** between a point $P(x_1, x_2, \dots, x_n)$ and the n -D-set \mathcal{S} as $\rho(x_1, x_2, \dots, x_n, \mathcal{S})$ on the linear (or non-linear) direction determined by the point P and the optimal point O (the line PO , or respectively the curvilinear PO) in the following way:

- d) $\rho(x_1, x_2, \dots, x_n, \mathcal{S}) =$ the *negative distance* between P and the set frontier, if P is inside the set \mathcal{S} ;
- e) $\rho(x_1, x_2, \dots, x_n, \mathcal{S}) = 0$, if P lies on the frontier of the set \mathcal{S} ;
- f) $\rho(x_1, x_2, \dots, x_n, \mathcal{S}) =$ the *positive distance* between P and the set frontier, if P is outside the set.

We got the following **properties**:

- a) It is obvious from the above definition of the extension n -D-distance between a point P in the universe of discourse and the extension n -D-set \mathcal{S} that:
 - i) Point $P(x_1, x_2, \dots, x_n) \in \text{Int}(\mathcal{S})$ iff $\rho(x_1, x_2, \dots, x_n, \mathcal{S}) < 0$;
 - ii) Point $P(x_1, x_2, \dots, x_n) \in \text{Fr}(\mathcal{S})$ iff $\rho(x_1, x_2, \dots, x_n, \mathcal{S}) = 0$;
 - iii) Point $P(x_1, x_2, \dots, x_n) \notin \mathcal{S}$ iff $\rho(x_1, x_2, \dots, x_n, \mathcal{S}) > 0$.

- b) Let \mathcal{S}_1 and \mathcal{S}_2 be two extension sets, in the universe of discourse U , such that they have no common end points, and $\mathcal{S}_1 \subset \mathcal{S}_2$. We assume they have the same optimal points $O_1 \equiv O_2 \equiv O$ located in their center of symmetry. Then for any point $P(x_1, x_2, \dots, x_n) \in U$ one has:

$$\rho((x_1, x_2, \dots, x_n), \mathcal{S}_1) \geq \rho((x_1, x_2, \dots, x_n), \mathcal{S}_2). \quad (28)$$

Then we proceed to the generalization of the dependent function from 1D-space to Linear (or Non-Linear) n -D-space Dependent Function, using the previous notations.

The **Linear (or Non-Linear) Dependent n -D-Function** of point $P(x_1, x_2, \dots, x_n)$ along the curve c , is:

$$K_{nD}(x_1, x_2, \dots, x_n) = \frac{\rho_c((x_1, x_2, \dots, x_n), \mathcal{S}_2)}{\rho_c((x_1, x_2, \dots, x_n), \mathcal{S}_2) - \rho_c((x_1, x_2, \dots, x_n), \mathcal{S}_1)} \quad (29)$$

(where c may be a curve or even a line)

which has the following **property**:

- f) If point $P(x_1, x_2, \dots, x_n) \in \text{Int}(\mathcal{S}_1)$, then $K_{nD}(x_1, x_2, \dots, x_n) > 1$;
- g) If point $P(x_1, x_2, \dots, x_n) \in \text{Fr}(\mathcal{S}_1)$, then $K_{nD}(x_1, x_2, \dots, x_n) = 1$;
- h) If point $P(x_1, x_2, \dots, x_n) \in \text{Int}(\mathcal{S}_2 - \mathcal{S}_1)$, then $K_{nD}(x_1, x_2, \dots, x_n) \in (0, 1)$;
- i) If point $P(x_1, x_2, \dots, x_n) \in \text{Int}(\mathcal{S}_2)$, then $K_{nD}(x_1, x_2, \dots, x_n) = 0$;
- j) If point $P(x_1, x_2, \dots, x_n) \notin \text{Int}(\mathcal{S}_2)$, then $K_{nD}(x_1, x_2, \dots, x_n) < 0$.

References:

- [1] Cai Wen. Extension Set and Non-Compatible Problems [J]. Journal of Scientific Exploration, 1983, (1): 83-97; also
Cai Wen. Extension Set and Non-Compatible Problems [A]. Advances in Applied Mathematics and Mechanics in China [C]. Peking: International Academic Publishers, 1990.1-21.
- [2] Cai Wen. Extension theory and its application, [J]. Chinese Science Bulletin, 1999, 44 (7): 673-682.
Cai Wen. Extension theory and its application, [J]. Chinese Science Bulletin, 1999, 44 (17): 1538-1548.
- [3] Yang Chunyan, Cai Wen. Extension Engineering [M]. Beijing: Science Press, 2007.
- [4] Wu Wenjun et al. "Research on Extension theory and its application" Expert Opinion. 2004, 2;
<http://web.gdut.edu.cn/~extenics/jianding.htm>.
- [5] Xiangshan Science Conferences Office. Scientific Significance and Future Development of Extenics – No. 271 Academic Discussion of Xiangshan Science Conferences, Brief Report of Xiangshan Science Conferences, Period 260, 2006, 1.

Applications of Extenics to 2D-Space and 3D-Space

Florentin Smarandache
University of New Mexico
Mathematics and Science Department
705 Gurey Ave.
Gallup, NM 87301, USA
E-mail: smarand@unm.edu

Victor Vlădăreanu
“Politehnica” University of Bucharest
Faculty of Electronics, II
313 Splaiul Independenței
060042 Bucharest
Romania

Abstract.

In this article one proposes several numerical examples for applying the extension set to 2D- and 3D-spaces. While rectangular and prism geometrical figures can easily be decomposed from 2D and 3D into 1D linear problems, similarly for the circle and the sphere, it is not possible in general to do the same for other geometrical figures.

1. Short Introduction.

Extenics has been used since 1983 by Cai Wen and many other Chinese scholars in solving contradictory problems. The distance between a number and a set, and the degree of dependence of a point with respect to a set were defined for the one-dimensional space, and later for higher dimensional spaces.

We present below several examples in 2D and 3D spaces.

2. Application 1.

We have a factory piece whose desired 2D-dimensions should be $20\text{ cm} \times 30\text{ cm}$, and acceptable 2D-dimensions $22\text{ cm} \times 34\text{ cm}$. We define the extension 2D-distance, and then we compute the extension 2D-dependent function. Let's do an extension diagram:

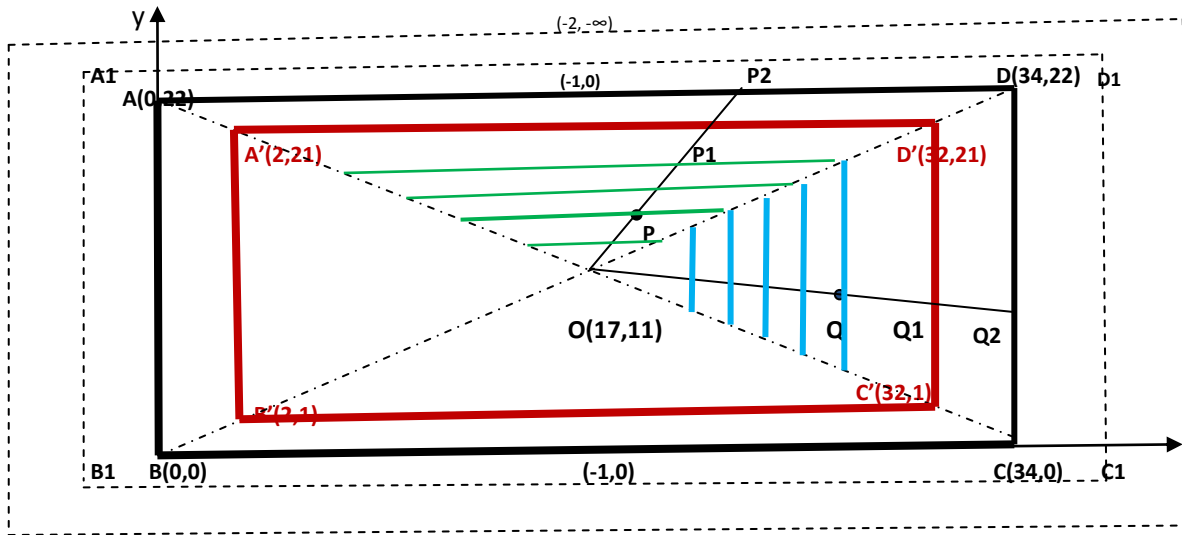

Diagram 1.

We have a desirable factory piece $A'B'C'D'$ and an acceptable factory piece $ABCD$. The optimal point for both of them is $O(17,11)$.

a) The region determined by the rays OA and OD .

The extension 2D-distance ρ between a point P and a set is the \pm distance from P to the closest frontier of the set, distance measured on the line OP . Whence

$$\rho(P, A'B'C'D') = -|PP_1| \quad (1)$$

and

$$\rho(P, ABCD) = -|PP_2|. \quad (2)$$

The extension 2D-dependent function k of a point P which represents the dependent of the point of the nest of the two sets is:

$$k(P) = \pm \frac{\rho(P, \text{bigger_set})}{\rho(P, \text{bigger_set}) - \rho(P, \text{smaller_set})} = \pm \frac{\rho(P, ABCD)}{\rho(P, ABCD) - \rho(P, A'B'C')} = \pm \frac{|PP_2|}{|PP_2| - |PP_1|} = \pm \frac{|PP_2|}{|P_1P_2|}. \quad (3)$$

In other words, the extension 2D-dependent function k of a point P is the 2D-extension distance between the point and the closest frontier of the larger set, divided by the 2D-extension distance between the frontiers of the two nested sets; all these 2D-extension distances are taken along the line OP .

In our application one has:

$$k(P) = + \frac{|PP_2|}{|P_1P_2|} \quad (4)$$

since P is inside of the larger set. If P was outside of the larger set, then k(P) would be negative.

Let's consider the coordinates of P(x₀, y₀), where P is between the rays OA and OD in order to make sure OP intersects the line segments AD and A'D' which are closest frontiers of the rectangles ABCD and respectively A'B'C'D'. {The problem would be similar if P was in between the rays OB and OC.}

Hence y₀ ∈ (11, ∞] but such y₀ that remains in between the rays OA and OD.

Let's find the coordinates of P₁.

In analytical geometry the equation of line OP passing through two points, O(17,11) and P(x₀, y₀), is:

$$y - 11 = \frac{y_0 - 11}{x_0 - 17} (x - 17). \quad (5)$$

Since the y-coordinate of P₁ is 21, we replace y = 21 in the above equation and we get the x-coordinate of P₁.

Whence one has P₁($\frac{10x_0 + 17y_0 - 357}{y_0 - 11}$, 21).

Let's find the coordinates of P₂.

The y-coordinate of P₂ is 22. Replace y = 22 in equation (2) and solve for the x-coordinate of P₂.

One gets P₂($\frac{11x_0 + 17y_0 - 374}{y_0 - 11}$, 22).

The classical distance in 2D-space between two points M(m₁, m₂), N(n₁, n₂) is

$$d(M, N) = \sqrt{(m_1 - n_1)^2 + (m_2 - n_2)^2}. \quad (6)$$

We compute the classical 2D-distances d(P, P₂) and d(P₁, P₂).

$$\begin{aligned}
k(P) &= \pm \frac{|PP_2|}{|P_1P_2|} = \pm \frac{\sqrt{\left(\frac{11x_0 + 17y_0 - 374}{y_0 - 11} - x_0\right)^2 + (22 - y_0)^2}}{\sqrt{\left(\frac{11x_0 + 17y_0 - 374}{y_0 - 11} - \frac{10x_0 + 17y_0 - 357}{y_0 - 11}\right)^2 + (22 - 21)^2}} \\
&= \pm \frac{\sqrt{\left(\frac{22x_0 + 17y_0 - x_0y_0 - 374}{y_0 - 11}\right)^2 + (y_0 - 22)^2}}{\sqrt{\left(\frac{x_0 - 17}{y_0 - 11}\right)^2 + 1}} = \pm \frac{\sqrt{\frac{(x_0 - 17)^2(y_0 - 22)^2}{(y_0 - 11)^2} + (y_0 - 22)^2}}{\frac{(x_0 - 17)^2}{(y_0 - 11)^2} + 1} \\
&= \pm |y_0 - 22| = \begin{cases} 22 - y_0, & y_0 \in (11, 22] \\ 22 - y_0, & y_0 > 22 \end{cases} = 22 - y_0, y_0 > 11
\end{aligned} \tag{7}$$

and P in between the rays OA and OD .

Since the extension $2D$ -dependent function $k(x_0, y_0) = 22 - y_0$, for $y_0 > 11$, does not depend on x_0 for the region between rays OA and OD , one has classes of points lying on horizontal lines parallel to $A'D'$ (see the green line segments on *Diagram 1*) whose extension $2D$ -dependent function value is the same. For example, the green horizontal line segment passing through P is the class of points having the same extension $2D$ -dependent function value as point P .

- b) The region determined by the rays OC and OD . {Similar result would obtain if one gets the opposite region determined by the rays OA and OB .}

If one takes another region determined by the rays OC and OD and a point $Q(x_1, y_1)$ in between one gets $k(Q) = k(x_1, y_1) = \pm \frac{|QQ_2|}{|Q_1Q_2|}$

$$(8)$$

By a similar method we find the Cartesian coordinates of the points Q_1 and Q_2 .

In analytical geometry the equation of line OQ passing through two points, $O(17, 11)$ and $Q(x_1, y_1)$, is:

$$y - 11 = \frac{y_1 - 11}{x_1 - 17}(x - 17). \tag{9}$$

Since the x -coordinate of Q_1 is 32, we replace $x = 32$ in the above equation and we get the y -coordinate of P_1 .

$$\text{Whence one has } Q_1\left(32, \frac{11x_1 + 15y_1 - 352}{x_1 - 17}\right). \tag{10}$$

Let's find the coordinates of Q_2 .

The x-coordinate of P_2 is 34. Replace $x=22$ in equation (3) and solve for the y-coordinate of Q_2 .

$$\text{One gets } Q_2\left(34, \frac{11x_1 + 17y_1 - 374}{x_1 - 17}\right). \quad (11)$$

We compute the classical 2D-distances $d(Q, Q_2)$ and $d(Q_1, Q_2)$.

$$\begin{aligned} k(P) &= \pm \frac{|QQ_2|}{|Q_1Q_2|} = \pm \frac{\sqrt{(34-x_1)^2 + \left(\frac{11x_1 + 17y_1 - 374}{x_1 - 17} - y_1\right)^2}}{\sqrt{(34-32)^2 + \left(\frac{11x_1 + 17y_1 - 374}{x_1 - 17} - \frac{11x_1 + 15y_1 - 352}{x_1 - 17}\right)^2}} \\ &= \pm \frac{\sqrt{(x_1-34)^2 + \frac{(x_1-34)^2(y_1-11)^2}{(x_1-17)^2}}}{\sqrt{4 + \frac{4(y_1-11)^2}{(x_1-17)^2}}} = \pm \frac{|x_1-34|}{2} = \frac{34-x_1}{2}, x_1 > 17 \end{aligned} \quad (12)$$

and Q in between the rays OC and OD .

Since the extension 2D-dependent function $k(x_1, y_1) = \frac{34-x_1}{2}$, for $x_1 > 17$, does not depend on y_1 for the region between rays OC and OD , one has classes of points lying on vertical lines parallel to $C'D'$ (see the red line segments on Diagram 1) whose extension 2D-dependent function value is the same. For example, the blue vertical line segment passing through Q is the class of points having the same extension 2D-dependent function value as point Q .

3. Splitting an extension 2D-problem into two 1D-problems.

Remarkably, for rectangular shapes one can decompose a 2D-problem into two 1D-problems. Yet, for other geometrical figures it is not possible. The more irregular geometrical figure, the less chance to decompose a 2D-problem into 1D-problems.

In our case, we separately consider the factory piece's width and length.

- 1) The width of a factory piece is desirable to be 20 cm and acceptable up to 22 cm.
- 2) And the length of a factory piece is desirable to be 30 cm and acceptable up to 34 cm.

In the first 1D-problem one makes the diagram:

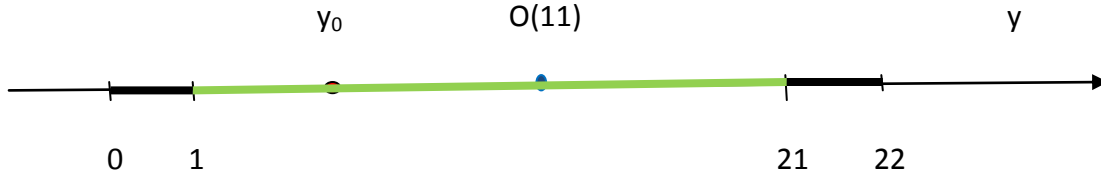

Diagram 2.

One computes, using Prof. Cai Wen's extension 1D-dependent function:

$$k(y_0) = \frac{|y_0 - 11| - \frac{22 - 0}{2}}{|y_0 - 11| - \frac{22 - 0}{2} - (|y_0 - 11| - \frac{21 - 1}{2})} = \frac{|y_0 - 11| - 11}{-11 + 10} = 11 - |y_0 - 11| \quad (13)$$

If $y_0 > 11$ as in our 2D-space problem, then $k(y_0) = 22 - y_0$ which is consistent with what we got in the 2D case.

In the second 1D-problem one makes the diagram:

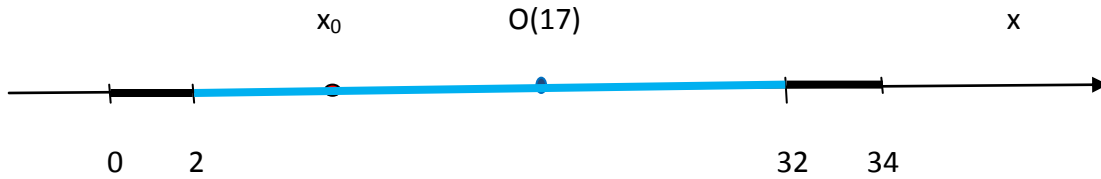

Diagram 3.

One computes, using Prof. Cai Wen's extension 1D-dependent function:

$$k(x_0) = \frac{|x_0 - 17| - \frac{34 - 0}{2}}{|x_0 - 17| - \frac{34 - 0}{2} - (|x_0 - 17| - \frac{32 - 2}{2})} = \frac{|x_0 - 17| - 17}{-17 + 15} = \frac{|x_0 - 17| - 17}{-2} = \frac{17 - |x_0 - 17|}{2} \quad (14)$$

If $x_0 > 17$ as in our 2D-space problem, then $k(x_0) = \frac{34 - x_0}{2}$, which is consistent with what we got in the 2D-case.

Therefore, a 2D-extension problem involving rectangles is equivalent with two 1D-extension problems. Certainly this equivalence is not valid any longer if instead of rectangles we have more irregular geometrical figures representing factory pieces.

Similarly will be possible for splitting a 3D-application for prisms into three 1D-applications, or into one 2D-application and one 1D-application.

4. Critical Zone.

Critical Zone is the region of points where the degree of dependence of a point P with respect to a nest of two intervals $k(P) \in (-1, 0)$.

In the above figure, it is all area between the rectangles $ABCD$ and $A_1B_1C_1D_1$.

$A_1B_1C_1D_1$ was constructed by drawing parallels to the sides of the rectangle $ABCD$, such that:

- The distance between the parallel lines $A'D'$ and AD , be the same with the distance between the parallel lines AD and A_1D_1 ;
- The distance between the parallel lines $A'B'$ and AB , be the same with the distance between the parallel lines AB and A_1B_1 ;
- The distance between the parallel lines $B'C'$ and BC , be the same with the distance between the parallel lines BC and B_1C_1 ;
- The distance between the parallel lines $C'D'$ and CD , be the same with the distance between the parallel lines CD and C_1D_1 .

One then extend the construction of a net of included rectangles $A_iB_iC_iD_i \subset A_{i+1}B_{i+1}C_{i+1}D_{i+1}$

and for the points P_{i+1} lying on surface in between the rectangles $A_iB_iC_iD_i$ and $A_{i+1}B_{i+1}C_{i+1}D_{i+1}$ the dependent function $k(P_{i+1}) \in (-i-1, -i)$.

5. Application in the 3D-space.

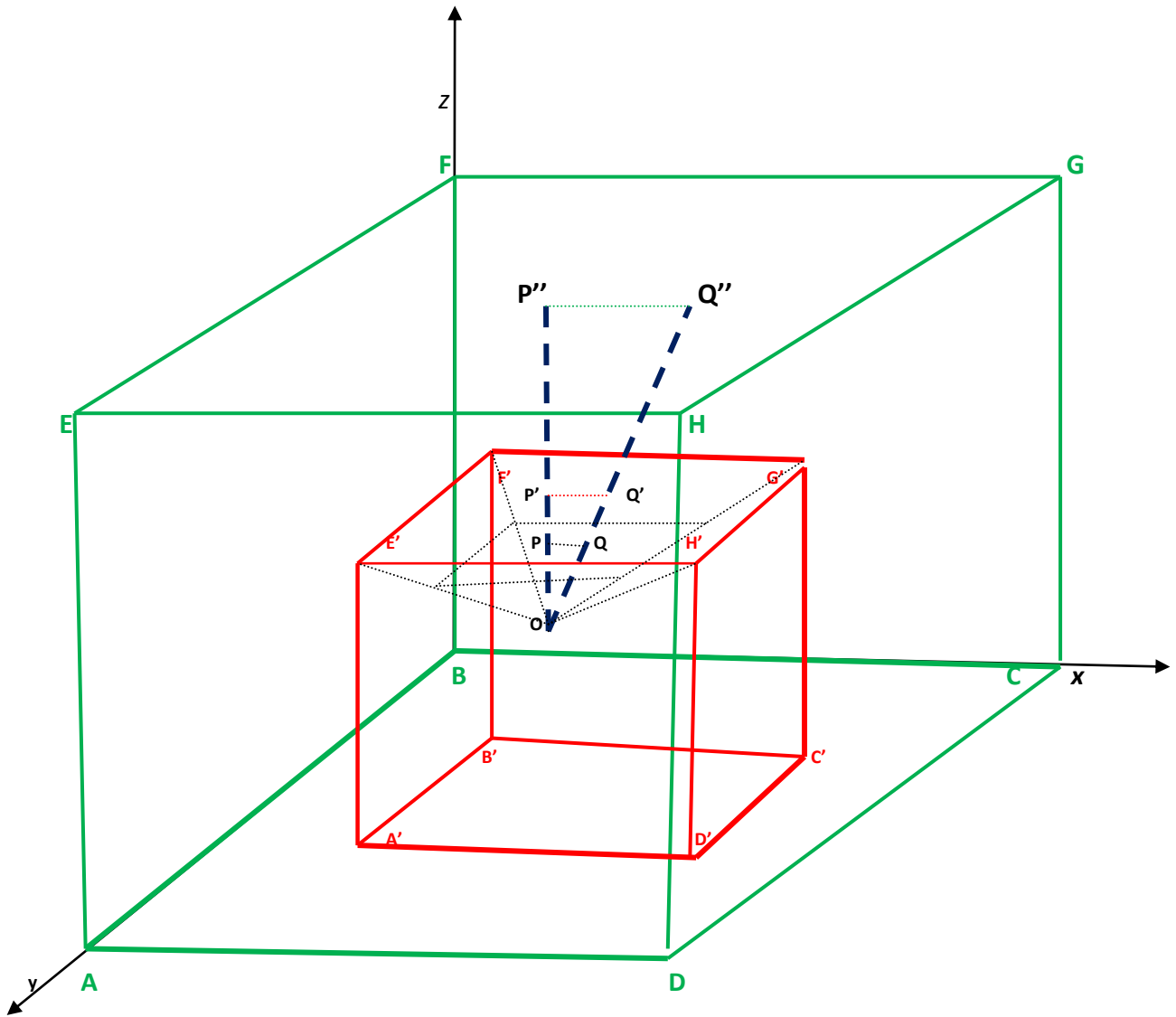

Diagram 4.

A factory piece has the desirable dimensions 20x30x7 but the acceptable factory piece can be 22x34x10 (in centimeters).

The red prism is the desirable form, and the green prism is the acceptable form.

We consider a Cartesian system XYZ and the vertices of these two prisms are:

$A(0,22,0)$, $B(0,0,0)$, $C(34,0,0)$, $D(34,22,0)$, $E(0,22,10)$, $F(0,0,10)$, $G(34,0,10)$, $H(34,22,10)$;

$A'(2,21,3)$, $B'(2,1,3)$, $C'(32,1,3)$, $D'(32,21,3)$, $E'(2,21,7)$, $F'(2,1,7)$, $G'(32,1,7)$, $H'(32,21,7)$.

$O(17,11,5)$; $P(x_0, y_0, z_0)$, $P'(x_1, y_1, 7)$, $P''(x_2, y_2, 10)$;

$Q(17,11,z_0)$, $Q'(17,11,7)$, $Q''(17,11,10)$. (15)

The following triangles are similar: $\triangle QOP$, $\triangle Q'OP'$, $\triangle Q''OP''$. Using similarity of triangles, Thales Theorem, and proportionalizations we get that:

$$\frac{|PP''|}{|P'P''|} = \frac{|QQ''|}{|Q'Q''|} \text{ which is equivalent to the equality of dependent function values of } k(P) = k(Q), \text{ since}$$

$$k(P) = \pm \frac{\rho(P, ABCDEFGH)}{\rho(P, ABCDEFGH) - \rho(P, A'B'C'D'E'F'G'H')} = \pm \frac{|PP''|}{|PP''| - |PP'|} = \pm \frac{|PP''|}{|P'P''|}$$

(16)

and similarly:

$$k(Q) = \pm \frac{\rho(Q, ABCDEFGH)}{\rho(Q, ABCDEFGH) - \rho(Q, A'B'C'D'E'F'G'H')} = \pm \frac{|QQ''|}{|QQ''| - |QQ'|} = \pm \frac{|QQ''|}{|Q'Q''|}.$$

(17)

Therefore, the plane which passes through the point P and is parallel with the planes $EFGH$ and $E'F'G'H'$ (limited by the lines OE' , OF' , OG' , OH') is the locus of points having the same dependent function value.

$$k(P) = \frac{z_0 - 10}{3} \text{ for } z_0 > 5 \text{ and point } P \text{ inside the reversed pyramid } OEFHG.$$

6. **The Critical Zone**, whose dependent function of each point in this zone belongs to $(-1, 0)$, will be a larger prism $A_1B_1C_1D_1E_1F_1G_1H_1$ which envelopes the prism $ABCDEFGH$ at the same distance from each face as it was between the prisms $A'B'C'D'E'F'G'H'$ and $ABCDEFGH$. Therefore, the distance between faces $A'B'C'D'$ and $ABCD$ is the same as the distance between faces $ABCD$ and $A_1B_1C_1D_1$; and the faces $A'B'C'D'$ and $ABCD$ and $A_1B_1C_1D_1$ are parallel. Similarly for all six faces of the prism $A_1B_1C_1D_1E_1F_1G_1H_1$: the distance between faces $A'E'H'D'$ and $AEHD$ is the same as the distance between faces $AEHD$ and $A_1E_1H_1D_1$; and the faces $A'E'H'D'$ and $AEHD$ and $A_1E_1H_1D_1$ are parallel. Etc.

One can construct a net of such prisms:

$A_{i+1}B_{i+1}C_{i+1}D_{i+1}E_{i+1}F_{i+1}G_{i+1}H_{i+1} \supset A_iB_iC_iD_iE_iF_iG_iH_i$ where the value of the dependent function for the points which belong to $Int(A_{i+1}B_{i+1}C_{i+1}D_{i+1}E_{i+1}F_{i+1}G_{i+1}H_{i+1} - A_iB_iC_iD_iE_iF_iG_iH_i)$ is in the interval $(-i-1, -i)$, while for the points lying on the $Fr(A_{i+1}B_{i+1}C_{i+1}D_{i+1}E_{i+1}F_{i+1}G_{i+1}H_{i+1})$ the dependent function is $-i-1$. One considers $ABCDEFGH$ as $A_0B_0C_0D_0E_0F_0G_0H_0$, and $A'B'C'D'E'F'G'H'$ as $A_{-1}B_{-1}C_{-1}D_{-1}E_{-1}F_{-1}G_{-1}H_{-1}$ for the rule to work for all included prisms.

7. Splitting a 3D-problem into three 1D-problem.

Similarly to the previous 2D-problem, we separately consider the factory piece's width, length, and height.

- 1) The width of a factory piece is desirable to be 20 cm and acceptable up to 22 cm.
- 2) And the length of a factory piece is desirable to be 30 cm and acceptable up to 34 cm.
- 3) And the height of a piece factory is desirable to be 7 cm and acceptable 10 cm.

In the first 1D-problem one makes the diagram:

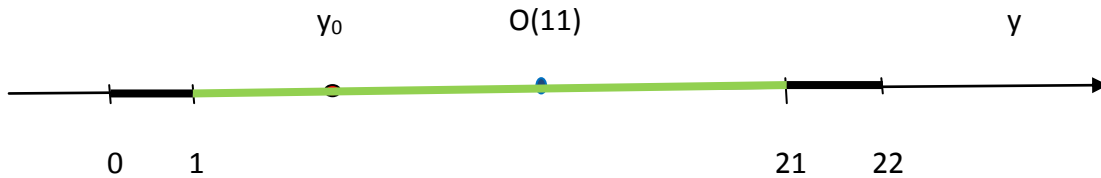

Diagram 5.

One computes, using Prof. Cai Wen's extension 1D-dependent function:

$$k(y_0) = 11 - |y_0 - 11| \quad (18)$$

In the second 1D-problem one makes the diagram:

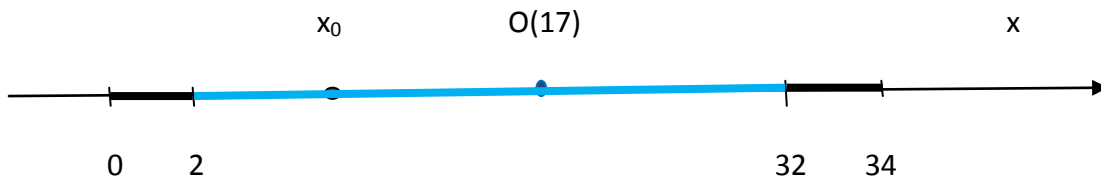

Diagram 6.

In the third 1D-problem one makes the diagram:

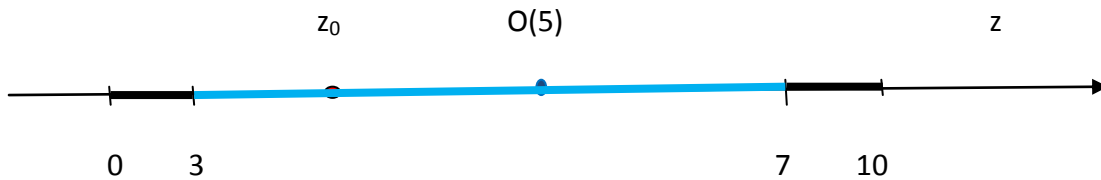

Diagram 7.

One computes, using Prof. Cai Wen's extension 1D-dependent function:

$$k(z_0) = \frac{z_0 - 10}{3} \quad (19)$$

8. Splitting a 3D-problem into a 2D-problem and a 1D-problem.

Similarly to the previous 2D-problem, we separately consider the factory piece's width, length, and height.

- 1) The factory 2D-piece is desirable to be 20x30 cm and acceptable up to 22x34 cm.
- 2) And the height of a piece factory is desirable to be 7 cm and acceptable 10 cm.

9. A 2D-problem which is split into only one 1D-problem.

Assume the desirable circular factory piece radius is 6 cm and acceptable is 8 cm.

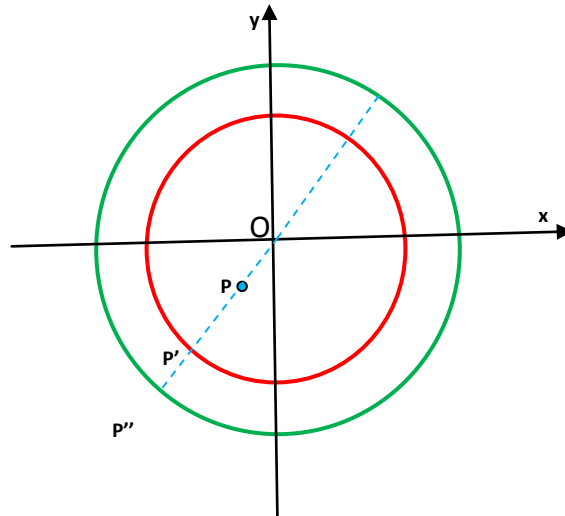

Diagram 8.

It is equivalent to a 1D-problem which has the diagram:

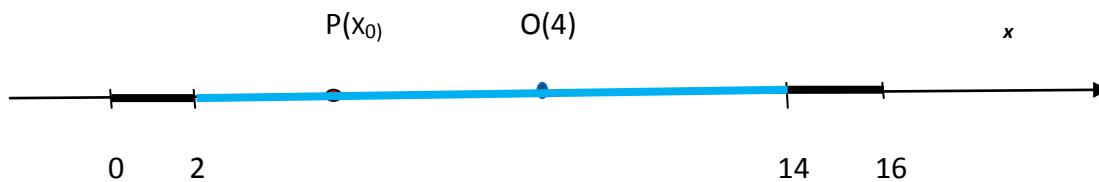

Diagram 9.

One computes, using Prof. Cai Wen's extension 1D-dependent function:

$$k(x_0) = \frac{x_0}{2} \quad (20)$$

10. A 2D-problem which cannot be split into 1D-problems.

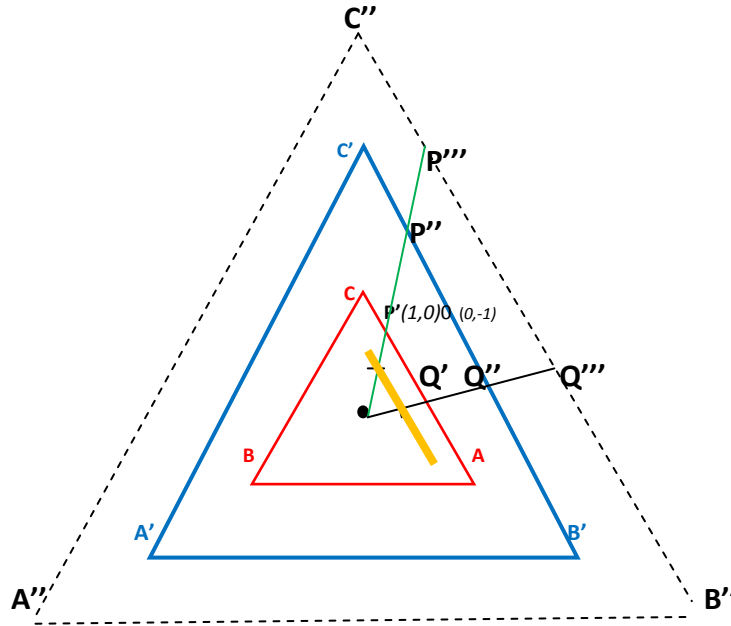

Diagram 10.

11. The **Critical Zone** is between the blue triangle $A'B'C'$ and the black dotted triangle $A''B''C''$. Points lying on lines parallel to the red triangle's sides have the same dependence function value (for example the points lying on the orange line segment).

12. Conclusion

In this paper we presented 2D-geometrical figures, such as two nested rectangles, two nested circles, and two nested triangles with no common ending points, and a 3D-geometrical figure, such as the two nested prisms with no common ending points, and we computed the dependent function values for a point with respect to these nested figures.

References:

- [1] Cai Wen. Extension Set and Non-Compatible Problems [J]. Journal of Scientific Exploration, 1983, (1): 83-97.
- [2] Yang Chunyan, Cai Wen. Extension Engineering [M]. Beijing: Science Press, 2007.

[3] F. Smarandache, Generalizations of the Distance and Dependent Function in Extenics to 2D, 3D, and n -D, *viXra.org*, <http://vixra.org/abs/1206.0014> and <http://vixra.org/pdf/1206.0014v1.pdf>, 2012.

Generalization of the Dependent Function in Extenics for Nested Sets with Common Endpoints to 2D-Space, 3D-Space, and generally to n-D-Space

Florentin Smarandache
University of New Mexico
Mathematics and Science Department
705 Gurey Ave.
Gallup, NM 87301, USA
E-mail: smarand@unm.edu

Abstract.

In this paper we extend Prof. Yang Chunyan and Prof. Cai Wen's dependent function of a point P with respect to two nested sets $X_0 \subset X$, for the case the sets X_0 and X have common ending points, from $1D$ -space to n - D -space. We give several examples in $2D$ - and $3D$ -spaces. When computing the dependent function value $k(.)$ of the optimal point O , we take its maximum possible value.

Formulas for computing $k(O)$, and the geometrical determination the Critical Zone are also given.

1. **Principle of Dependent Function** of a point $P(x)$ with respect to a nest of two sets $X_0 \subset X$, i.e. *the degree of dependence of point P with respect to the nest of the sets $X_0 \subset X$* , is the following.

The dependent function value, $k(x)$, is computed as follows:

- *the extension distance between the point P and the larger set's closest frontier, divided by the extension distance between the frontiers of the two sets {both extension distances are taken on the line/geodesic that passes through the point P and the optimal/attracting point O };*
- *the dependent function value is positive if point P belongs to the larger set, and negative if point P is outside of the larger set.*

2. **Dependent Function Formula for nested sets having common ending points in 1D-Space.**

For two nested sets $X_0 \subset X$ from the one-dimensional space of real numbers R , with X_0 and X having common endpoints, the **Dependent Function** $K(x)$, which gives the degree of dependence of a point x with respect to this pair of included $1D$ -intervals, was defined by Yang Chunyan and Cai Wen in [2] as:

$$K(x) = \begin{cases} \frac{\rho(x, X)}{\rho(x, X) - \rho(x, X_0)} & \rho(x, X) - \rho(x, X_0) \neq 0, x \in X \\ -\rho(x, X_0) + 1 & \rho(x, X) - \rho(x, X_0) = 0, x \in X_0 \\ -\rho(x, X) & \rho(x, X) - \rho(x, X_0) = 0, x \notin X_0, x \in X \\ \frac{\rho(x, X)}{\rho(x, X) - \rho(x, \hat{X})} & \rho(x, X) - \rho(x, \hat{X}) \neq 0, x \in R - X \\ -\rho(x, \hat{X}) - 1 & \rho(x, X) - \rho(x, \hat{X}) = 0, x \in R - X \end{cases} \quad (1)$$

where $X_0 = \langle a_0, b_0 \rangle$, $X = \langle a, b \rangle$, $\hat{X} = \langle c, d \rangle$, and $X_0 \subset X \subset \hat{X}$.

3. n -D-Dependent Function Formula for two nested sets having no common ending points.

The extension n -D-dependent function $k(\cdot)$ of a point P , which represents the degree of dependence of the point P with respect to the nest of the two sets $X_0 \subset X$, is:

$$k(P) = \frac{\rho(P, \text{BiggerSet})}{\rho(P, \text{BiggerSet}) - \rho(P, \text{SmallerSet})} = \frac{\rho_{nD}(P, X)}{\rho_{nD}(P, X) - \rho_{nD}(P, X_0)} = \pm \frac{|PP_2|}{|PP_2| - |PP_1|} = \pm \frac{|PP_2|}{|P_1P_2|} \quad (2)$$

In other words, the extension n -D-dependent function $k(\cdot)$ of a point P is the n -D-extension distance between the point P and the closest frontier of the larger set X , divided by the n -D-extension distance between the frontiers of the two nested sets X and X_0 ; all these n -D-extension distances are taken along the line (or geodesic) OP .

4. n -D-Dependent Function Formula for two nested sets having common ending points.

We generalize the above formulas (1) and (2) to an **n -D Dependent Function** of a point $P(x_1, x_2, \dots, x_n)$ with respect to the nested sets X_0 and X having common endpoints, $X_0 \subset X$, from the universe of discourse U , in the n -D-space:

$$K_{nD}((x_1, x_2, \dots, x_i)) = \begin{cases} \frac{\rho_{nD}((x_1, x_2, \dots, x_i), X)}{\rho_{nD}((x_1, x_2, \dots, x_i), X) - \rho_{nD}((x_1, x_2, \dots, x_i), X_0)} & \rho_{nD}((x_1, x_2, \dots, x_i), X) - \rho_{nD}((x_1, x_2, \dots, x_i), X_0) \neq 0, (x_1, x_2, \dots, x_i) \in U \\ -\rho_{nD}((x_1, x_2, \dots, x_i), X_0) + 1 & \rho_{nD}((x_1, x_2, \dots, x_i), X) - \rho_{nD}((x_1, x_2, \dots, x_i), X_0) = 0, (x_1, x_2, \dots, x_i) \in X_0 \\ -\rho_{nD}((x_1, x_2, \dots, x_i), X) & \rho_{nD}((x_1, x_2, \dots, x_i), X) - \rho_{nD}((x_1, x_2, \dots, x_i), X_0) = 0, (x_1, x_2, \dots, x_i) \in U - X_0 \end{cases} \quad (3)$$

5.1. Example 1 of nested rectangles with one common side.

We have a factory piece whose desired 2D-dimensions should be $20 \text{ cm} \times 30 \text{ cm}$, and acceptable 2D-dimensions $22 \text{ cm} \times 32 \text{ cm}$, but the two rectangles have common ending points. We define the

extension 2D-distance, and then we compute the extension 2D-dependent function. Let's do an extension 2D-diagram:

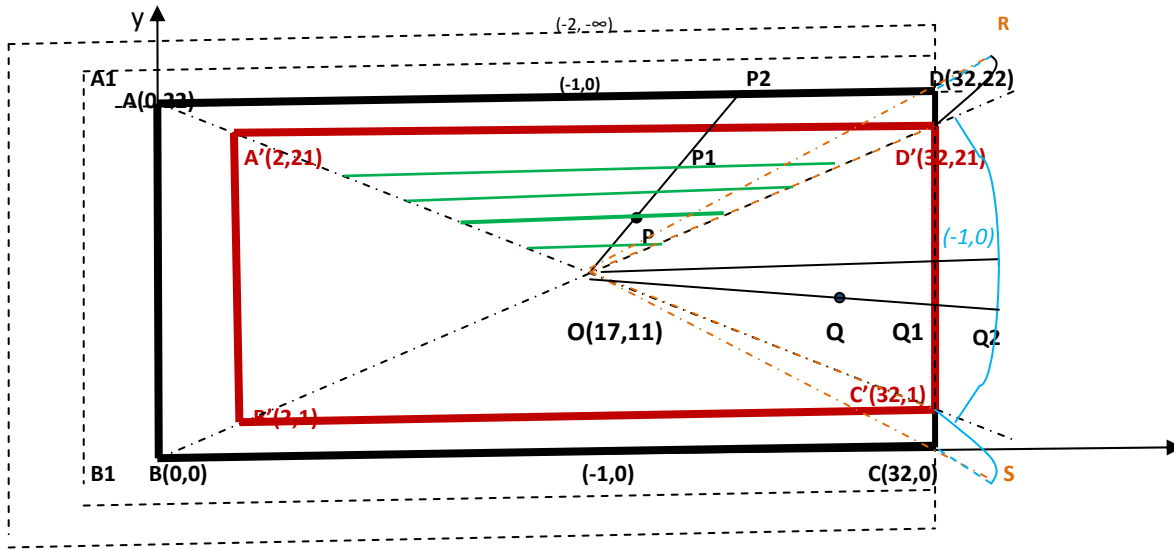

The Critical Zone in the top, down, and left sides of the Diagram 1 as the same as for the case when the two pink and black rectangles have no common ending points. But on the right-hand side the Critical Zone is delimited by the a blue curve in the middle and the blue dotted lines in the upper and lower big rectangle's corners.

The dependent function of the points Q, Q_1, Q_2 is respectively:

$$k(Q) = |QQ_1| + 1, \text{ and } k(Q_1) = 1 \text{ (if } Q_1 \in A'B'C'D') \text{ or } 0 \text{ (if } Q_1 \notin A'B'C'D'), \text{ and } k(Q_2) = -|Q_2Q_1| = -1, \text{ (4)}$$

where $|MN|$ means the geometrical distance between the points M and N .

The dependent function of point P is normally computing:

$$k(P) = \frac{|PP_2|}{|P_1P_2|}. \quad (5)$$

5.2. Example 2 of nested rectangles with two common sides.

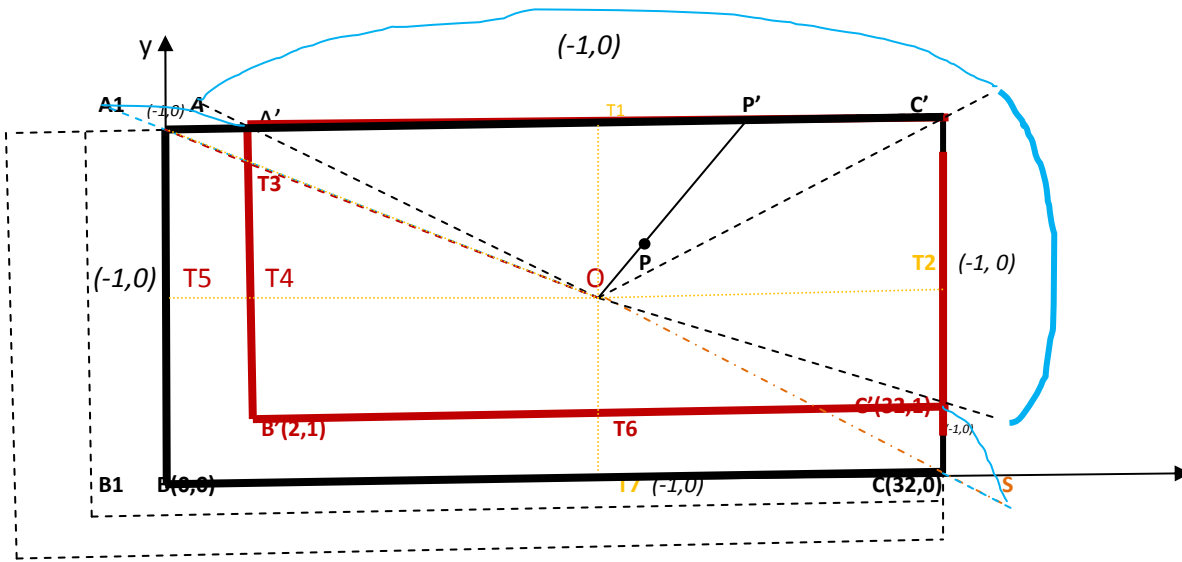

Diagram 2.

We observe that the Critical Zone changes dramatically in the places where the common ending points occur, i.e. on the top and respectively left-hand sides. The Critical Zone is delimited by blue curves and lines on the top and respectively left-hand sides.

Now, the dependent function of point P is different from the Diagram 1:

$$k(P) = |PP'| + 1. \quad (6)$$

The dependent function of the optimal point O should be the maximum possible value.

Therefore,

$$k(O) = \max \{ |OT_1| + 1, |OT_2| + 1, |OP'| + 1, |OC'| + 1, \frac{|OT_7|}{|T_6T_7|}, \frac{|OT_5|}{|T_4T_5|}, \frac{|OA|}{|T_3A|}, \text{etc.} \}. \quad (7)$$

5.3. Example 3 of nested circles with one common ending point.

Assume the desirable circular factory piece radius is 6 cm and acceptable is 8 cm, but they have a common ending point P' .

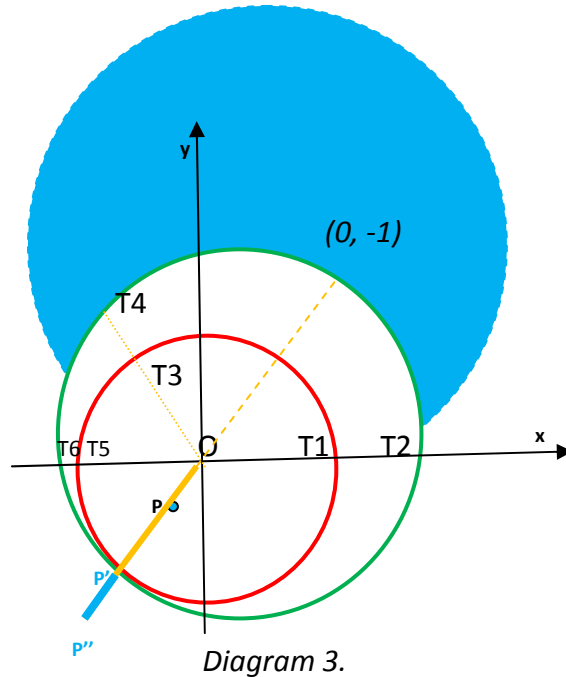

The Critical Zone is between the green and blue circles, together with the blue line segment $P''P'$ (this line segment resulted from the fact the P' is a common ending point of the red and green circles).

The dependent function values for the following points are:

$$k(P) = |PP'| + 1; \tag{8}$$

$$k(P') = 1 \text{ (if } P' \text{ belongs to the red circle), or } 0 \text{ (if } P' \text{ does not belong to the red circle);} \tag{9}$$

$$k(P'') = |P''P'|; \tag{10}$$

$$k(O) = \max \left\{ |OP'| + 1; \frac{|OT_4|}{|T_3T_4|} \right\}, \tag{11}$$

where T_3 lies arbitrary on the red circle, but $T_3 \neq P'$, and T_4 lies on the green circle but T_4 belongs to the line (or geodesic) OT_3 .

5.4. Example 4 of nested triangles with one common bottom side.

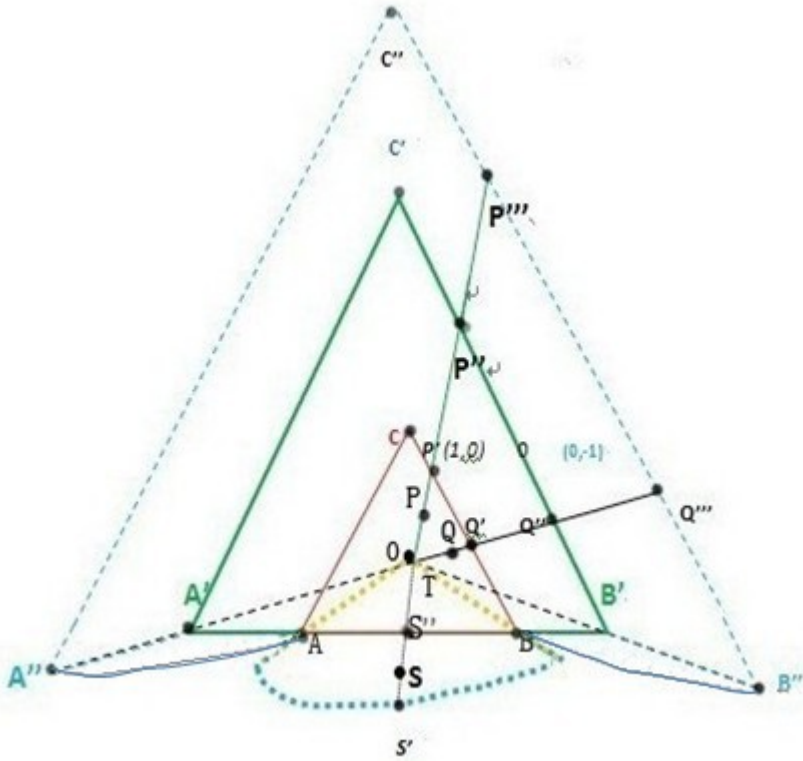

Diagram 4.

The Critical Zone is between the green and blue dotted triangle to the left-hand and right-hand sides, while at the bottom side the Critical Zone is delimited by the blue curve in the middle and the blue small oval triangles $A''AA'$ and respectively $B''BB'$.

The dependent function values of the following points are given below:

$$k(P) = \frac{|PP''|}{|P'P''|} > 1; k(P')=1; k(P'')=0; k(P''') = -1. \quad (12)$$

$$\text{Similarly: } k(Q) = \frac{|QQ''|}{|Q'Q''|} > 1; k(Q')=1; k(Q'')=0; k(Q''') = -1. \quad (13)$$

With respect to the bottom common side (where the line segment AB lies on line segment $A'B'$) one has:

$$k(T) = |TS''|+1; k(S'') = 1 \text{ (if } S'' \text{ belongs to the red triangle } ABC), \text{ or } 0 \text{ (if } S'' \text{ does not belong to the red triangle } ABC); k(S) = |SS''|; k(S') = -1. \quad (14)$$

$$k(O) = \max \left\{ \max_{S'' \in [AB]} (|OS''| + 1); \max_{\substack{P' \in [AC] \cup [CB], P'' \in [A'C'] \cup [C'B'] \\ P \in OP'' \\ OPP'' \text{ line/geodesic}}} \left(\frac{|OP''|}{|P'P''|} \right) \right\}. \quad (15)$$

5.5. Example 5 in 3D-Space of two prisms having a common face.

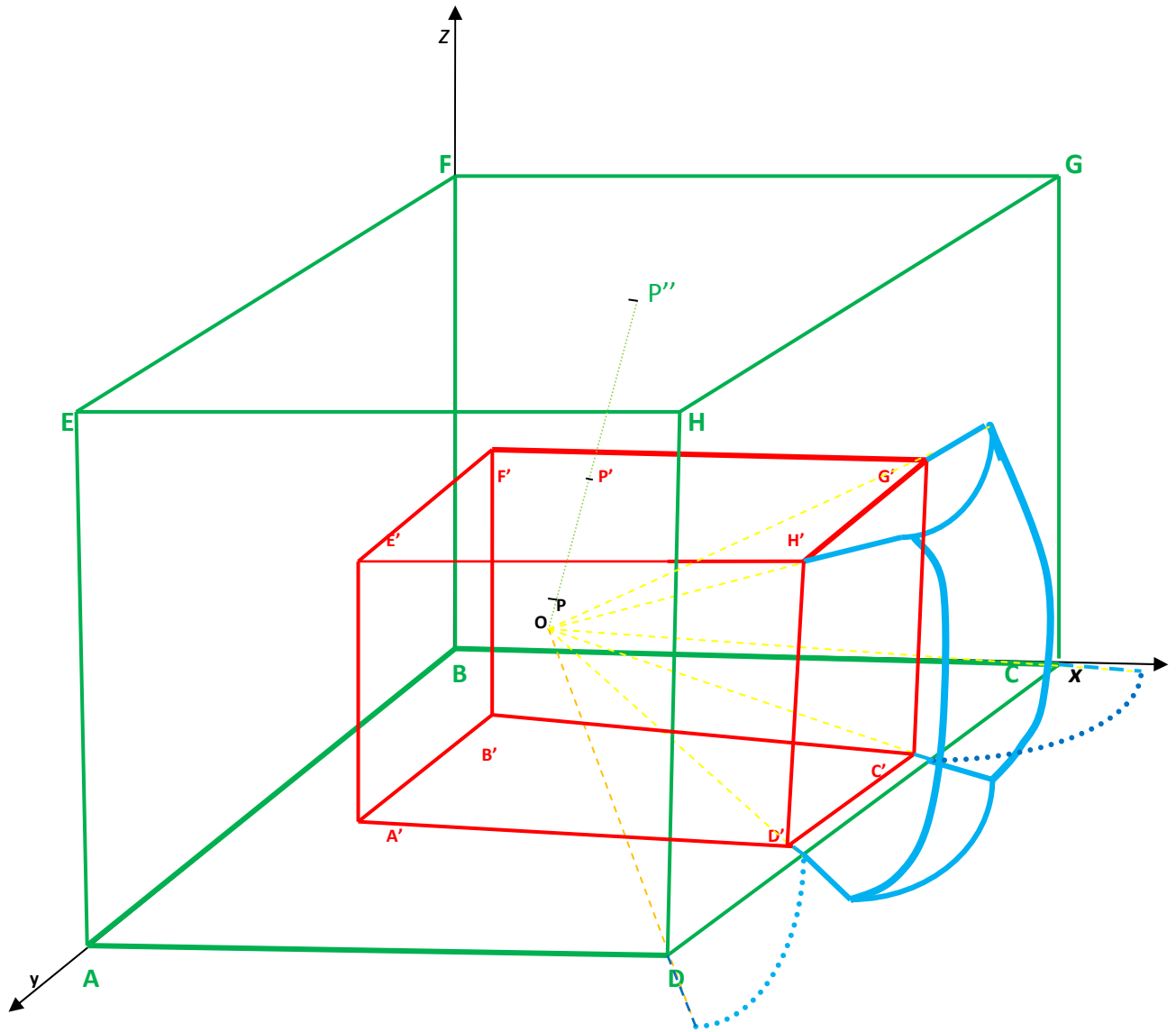

Diagram 5.

The Critical Zone (the zone where the extension dependent function takes values between 0 and -1) envelopes the larger green prism $ABCDEFGH$ at an equal distance from it as the distance between the red prism $A'B'C'D'E'F'G'H'$ and the green prism $ABCDEFGH$ with respect to the faces $ABCD$, $ADHE$, $BCGF$, $EFGH$, and $ABFE$ (because these green faces and their corresponding

red faces $A'B'C'D'$, $A'D'H'E'$, $B'C'G'F'$, $E'F'G'H'$, and respectively $A'B'F'E'$ have no common points).

But the green face $DCGH$ contains the red face $D'C'G'H'$, therefore for all their common points (i.e. all points inside of and on the rectangle $D'C'G'H'$) the extension dependent function has wild values. $D'C'G'H'$ entirely lies on $DCGH$. The Critical Zone related to the right-hand green face $DCGH$ and the red face $D'C'G'H'$ is the solid bounded by the blue continuous and dashed curves on the right-hand side.

In general, let's consider two n -D sets, $S_1 \subset S_2$, that have common ending points (on their frontiers). Let's note by C_E their common ending point zone. Then:

The Dependent Function Formula for computing the value of the Optimal Point O is

$$k(O) = \max \left\{ \max_{S'' \in C_E} (|OS''| + 1); \max_{\substack{P' \in Fr(S_1 - C_E), P'' \in Fr(S_2 - C_E) \\ P' \in OP'' \\ OPP'' \text{ line / geodesic}}} \left(\frac{|OP''|}{|P'P''|} \right) \right\}. \quad (16)$$

We can define the Critical Zone in the sides where there are common ending points as:

$$Z_{C1} = \{P(x) | P \in U-S_2, 0 < d(P, P'') \leq 1, P'' \in Fr(S_1) \cap Fr(S_2) \text{ and } P'' \in OP\}, \quad (17)$$

where $d(P, P'')$ is the classical geometrical distance between the points P and P'' .

And for the sides which have no common ending points, the Critical Zone is:

$$Z_{C2} = \{P(x) | P \in U-S_2, 0 < d(P, P'') \leq d(P''P'), \text{ where } P'' \in Fr(S_2) \text{ and } P' \in Fr(S_1) \text{ and } P'' \in OP\}. \quad (18)$$

$$\text{Whence, the total Critical Zone is: } Z_C = Z_{C1} \cup Z_{C2}. \quad (19)$$

References:

- [1] Cai Wen. Extension Set and Non-Compatible Problems [J]. Journal of Scientific Exploration, 1983, (1): 83-97.
- [2] Yang Chunyan, Cai Wen. Extension Engineering [M]. Beijing: Science Press, 2007.
- [3] F. Smarandache, Generalizations of the Distance and Dependent Function in Extenics to 2D, 3D, and n -D, viXra.org, <http://vixra.org/abs/1206.0014> and <http://vixra.org/pdf/1206.0014v1.pdf>, 2012.
- [4] F. Smarandache, V. Vlădăreanu, Applications of Extenics to 2D-Space and 3D-Space, viXra.org, <http://vixra.org/abs/1206.0043> and <http://vixra.org/pdf/1206.0043v2.pdf>, 2012.

Generalizations in Extenics of the Location Value and Dependent Function from A Single Finite Interval to $2D$, $3D$, and $n-D$ Spaces

Florentin Smarandache
University of New Mexico
Mathematics and Science Department
705 Gurley Dr.
Gallup, NM 87301, USA
E-mail: smarand@unm.edu

Mihai Liviu Smarandache
Internet Application Developer, GIZMO Creative, Inc.
Hong Kong, P.R. China
E-mail: mihailiviu@yahoo.com

Abstract.

Qiao-Xing Li and Xing-Sen Li [1] have defined in 2011 the Location Value of a Point and the Dependent Function of a Point on a single finite or infinite interval. In this paper we extend their definitions from one dimension ($1D$) to $2D$, $3D$, and in general $n-D$ spaces. Several examples are given in $2D$ and $3D$ spaces.

1. Short Introduction to Extenics.

In this paper we make a short description of Extenics, and then we present an extension of the Location Value of a Point and the Dependent Function of a Point from $1D$ to $n-D$, with several examples in the particular cases of $2D$ and $3D$ spaces. Improvement of the Extenics website is given towards the end, followed by an Extenics what-to-do list.

Extenics is a science initiated by Professor Cai Wen in 1983. It is at the intersection of mathematics, philosophy, and engineering. Extenics solves contradictory problems. It is based on modeling and remodeling, on transforming and retransforming until getting a reasonable solution to apparently an unreasonable problem.

Extenics solves unconventional and non-traditional problems and finding ingenious, perspicacious and novelty solutions.

Extenics helps in solving problems in hard conditions, incomplete conditions, conflicting conditions. Where mathematics doesn't work, i.e. for inconsistent problems where mathematics says that there is no solution, Extenics does work because it can obtain a solution.

Everything is dynamic; we have dynamic structure, dynamic classification, and dynamic change.

In Extenics a problem may have more solutions, some of them even contradictory with each other, but all of them can be valid solutions.

The five basic transformations are: substitution, increasing/decreasing, expansion/contraction, decomposition, and duplication.

Extenics studies:

- the antithetic properties of the matter: physical part (real) and non-physical part (imaginary), soft and hard parts of the matter, negative and positive parts of the matter;
- unfeasible problems are transformed to feasible problems;
- false propositions are transformed in true propositions;
- wrong inference is transformed into correct inference;
- transform non-conformity to conformity;
- in business non –customers are transformed to customers;
- there are qualitative and quantitative transformations;
- transformation of matter-element, transformation of affair-element, transformation of relation-element;
- transformation of the characteristics;
- one considers transformation of a single part too (not of the whole);
- Extenics deals with unconventional problems which are transformed into conventional;
- inconsistent problems are transformed into consistent;
- also one determines the composability and conductivity of transformations;
- Extenics finds rules and procedures of solving contradictory problems;
- get structures and patterns to deal with contradictions;
- get new methods of solving contradictions;
- reduces the degree of inconsistency of the problems;
- from divergent to less-divergent.

2. Location Value of a Point and the Dependent Function on a Single Finite Interval (on 1D-Space).

Suppose $S = \langle a, b \rangle$ is a finite interval. By the notation $\langle a, b \rangle$ one understands any type of interval: open (a, b) , closed $[a, b]$, or semi-open/semi-closed $(a, b]$ and $[a, b)$.

a) For any real point $x_0 \in R$, Qiao-Xing Li and Xing-Sen Li have considered

$$D(x_0, S) = a-b \tag{1}$$

as the location value of point $P(x_0)$ on the single finite interval $\langle a, b \rangle$.

Of course $D(x_0, S) = D(P, S) < 0$, since $a < b$.

As we can see, $a-b$ is the negative distance between the frontiers of the single finite interval S in the $1D$ -space.

b) Afterwards, the above authors defined for any real point $P(x_0)$, with $x_0 \in S$, the elementary dependent function on the single interval S in the following way:

$$k(x_0) = \frac{\rho(x_0, S)}{D(x_0, S)} \quad (2)$$

where $\rho(x_0, S)$ is the extension distance between point x_0 and the finite interval X in the ID -space. Or we can re-write the above formula as:

$$k(P) = \frac{\rho(P, S)}{D(P, S)}. \quad (3)$$

3. We have introduced in [2] the **Attraction Point Principle**, which is the following:

Let S be a given set in the universe of discourse U , and the optimal point $O \in S$. Then each point $P(x_1, x_2, \dots, x_n)$ from the universe of discourse tends towards, or is attracted by, the optimal point O , because the optimal point O is an ideal of each other point. There could be one or more linearly or non-linearly trajectories (curves) that the same point P may converge on towards O . Let's call all such points' trajectories as the **Network of Attraction Curves (NAC)**.

4. **Generalizations of the Location Value of a Point and the Dependent Function on a Single Finite Set on the n-D-Space.**

In general, in a universe of discourse U , let's have an n -D-set S and a point $P \in U$.

a) The **Generalized Location Value of Point P on the Single Finite Set S in n -D Space**,

$D_{nD}(x_0, S)$, is the classical geometric distance (yet taken with a negative sign in front of it) between the set frontiers, distance taken on the line (or in general taken on the curve or geodesic) passing through the optimal point O and the given point P .

In there are many distinct curves passing through both O and P in the Network of Attraction Curves, then one takes that curve for which one gets the maximum geometric distance (and one assigns a negative sign in front of this distance).

We can also denote it as $D_{nD}(P, S)$.

b) We geometrically studied the ID -Extension Distance $\rho(x_0, S)$ in our first Extenics paper [2] and we found out that the following principle was used by Prof. Cai Wen in 1983:

$\rho(x_0, S)$ = the classical geometric distance between the point x_0 and the closest extremity point of the interval $\langle a, b \rangle$ to it (going in the direction that connects x_0 with the optimal point), distance taken as negative if $x_0 \in \text{Int}(\langle a, b \rangle)$, as positive if $x_0 \notin \text{Ext}(\langle a, b \rangle)$, and as zero if

$x_0 \in \text{Fr}(\langle a, b \rangle)$,

where $\text{Int}(\langle a, b \rangle) = \text{interior of } \langle a, b \rangle$,

$\text{Ext}(\langle a, b \rangle) = \text{exterior of } \langle a, b \rangle$,

and $\text{Fr}(\langle a, b \rangle) = \text{frontier of } \langle a, b \rangle$.

(4)

Thus we have defined the **Generalized Extension Linear/Non-Linear n -D-Distance** between point P and set S , as:

$$\rho_{nD}(P, S) = \begin{cases} -\max_{c \in NAC} d(P, P'; c), & P \neq O, P \in c(OP'); \\ \max_{\substack{c \in NAC \\ P' \in Fr(S)}} d(P, P'; c), & P \neq O, P' \in c(OP); \\ -\max_{c \in NAC, M \in Fr(S), M \in c(O)} d(P, M; c), & P=O. \end{cases} \quad (5)$$

where $\rho_{nD}(P, S)$ means the extension distance as measured along the curve c in the n - D space;
 O is the optimal point (or non-linearly attraction point);
the points are attracting by the optimal point O on trajectories described by an injective curve c ;
 $d(P, P'; c)$ means the non-linearly n - D -distance between two points P and P' along the curve c , or the arclength of the curve c between the points P and P' ;
 $Fr(S)$ means the frontier of set S ;
and $c(OP')$ means the curve segment between the points O and P' (the extremity points O and P' included), therefore $P \in c(OP')$ means that P lies on the curve c in between the points O and P' .
For P coinciding with O , one defined the distance between the optimal point O and the set S as the negatively maximum curvilinear distance (to be in concordance with the ID -definition).
In the same way, if there are many curves, c in the Network of Attraction Curves, passing through both O and P , then one chooses that curve which maximizes the geometric distance.

We do these maximizations in order to be consistent with the case when the point P coincides with the optimal point O .

We now proceed to defining the **Generalized Dependent Function on a Single Finite Set S in n - D -Space of Point P** :

$$k_{nD}(P) = \max_{c \in NAC} \frac{\rho_{nD}(P, S; c)}{D_{nD}(P, S; c)} \quad (6)$$

or using words: the Generalized Dependent Function on a Single Finite Set S of point P is the geometric distance between point P and the closest frontier on the line (or in general on the curve/geodesic c that connects P with the optimal point O) in the same side of the optimal point, divided by the distance [taken along the line (or in general on the curve/geodesic c that connects P with the optimal point O)] between the set frontiers.

If there are more curves passing through P and O , then one takes that curve which maximizes the value of $k_{nD}(P)$.

5. Examples of 2D-Dependent Function on a Single Finite Set.

Let's retake a previous example with two rectangles, $A_0M_0B_0N_0$ and $AMBN$, whose sides are parallel to the axes of the Cartesian system of coordinates, such that they have no common end points, and $A_0M_0B_0N_0 \subset AMBN$. The optimal point is O located in their center of symmetry.

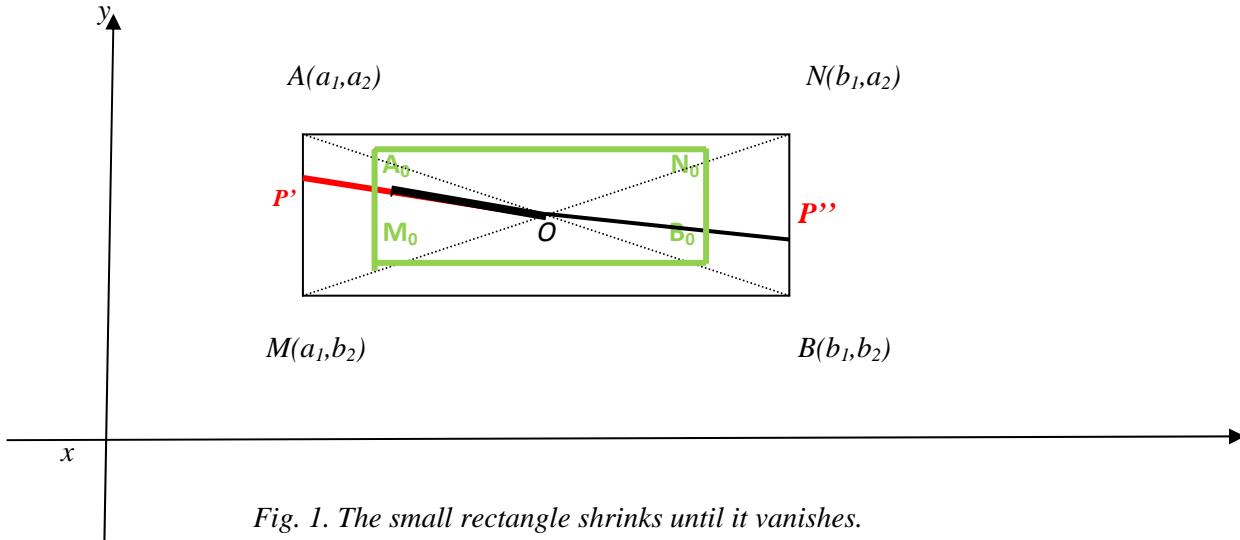

Fig. 1. The small rectangle shrinks until it vanishes.

If there is only a single finite set $AMBN$, this means that the other set $A_0M_0B_0N_0$ (which is included in $AMBN$) is shrinking little by little until it vanishing, thus the $(0, 1)$ value of the dependent function of two nested sets increases until occupying the whole interior of the big set $AMBN$:

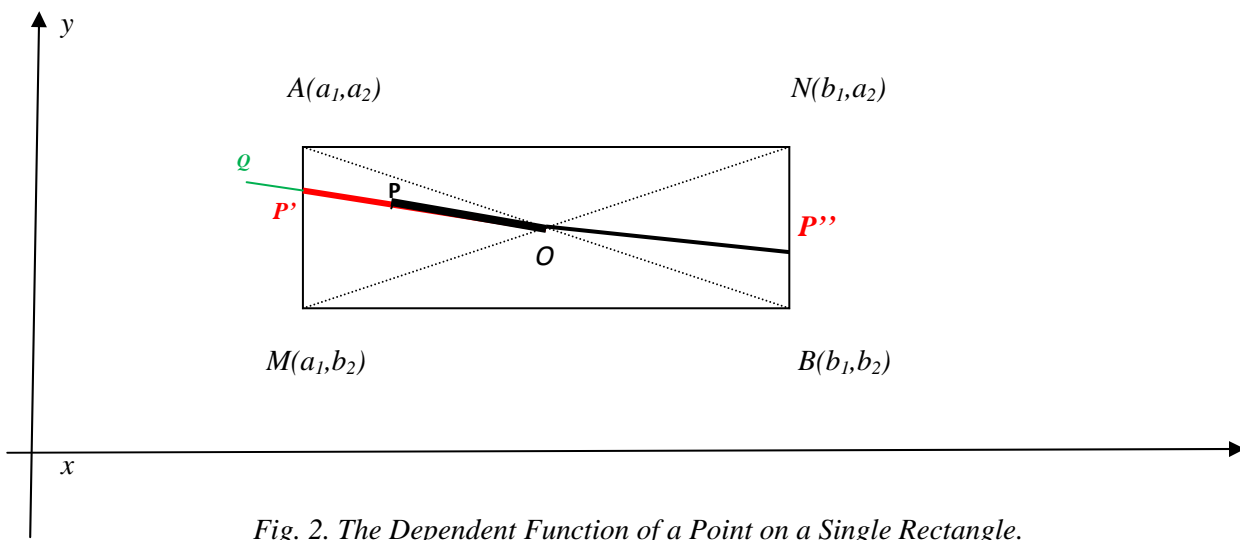

Fig. 2. The Dependent Function of a Point on a Single Rectangle.

The dependent function of interior point P with respect to the single rectangle $AMBN$ is:

$$k(P) = + \frac{|PP'|}{|P''P'|} \tag{7}$$

i.e. the distance between P and the closest frontier of the rectangle $\{ =|PP'| \}$, divided by the distance between the frontiers of the rectangle $\{ =|P''P'| \}$.

The dependent function of exterior point Q with respect to the single rectangle $AMBN$ is:

$$k(Q) = -\frac{|QP'|}{|P''P'|}. \quad (8)$$

And the dependent function of frontier point P' with respect to the single rectangle $AMBN$ is:

$$k(P') = \frac{|P'P'|}{|P''P'|} = 0. \quad (9)$$

In this example we have considered only one curve of convergence for each point in the Network of Attraction Curves.

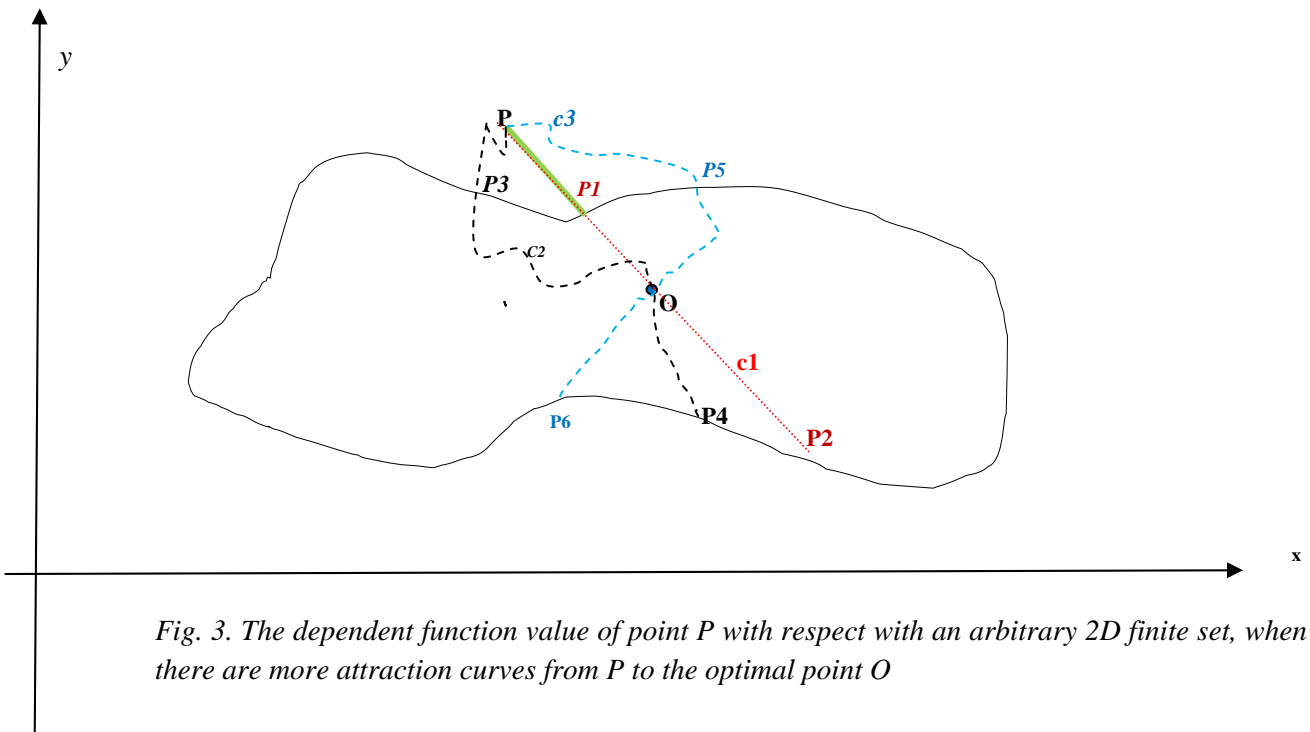

Fig. 3. The dependent function value of point P with respect with an arbitrary 2D finite set, when there are more attraction curves from P to the optimal point O

The dependent function value of point P is:

$$k(P) = -\max \left\{ \frac{c1(PP1)}{c1(P1P2)}, \frac{|PP1|}{|P1P2|}, \frac{c2(PP3)}{c2(P3P4)}, \frac{c3(PP5)}{c3(P5P6)} \right\} \quad (10)$$

where $c1(PP1)$ means the arclength between the points P and $P1$ on the curve $c1$ (which happens in this case to be just a line segment), and similarly $c2(,..)$ and $c3(,..)$.

6. Example of 3D-Dependent Function on a Single Finite Set.

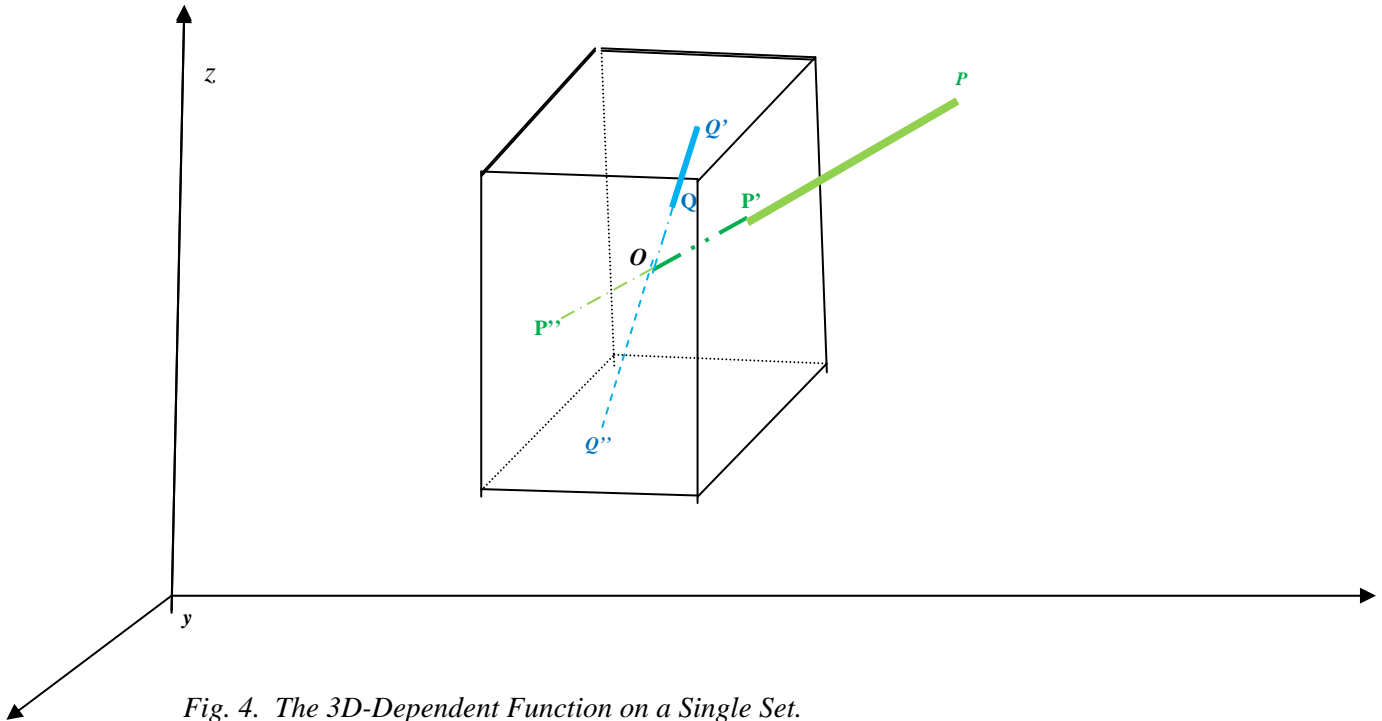

Fig. 4. The 3D-Dependent Function on a Single Set.

The dependent values on the single 3D-set is calculated for the following points:

$$k(P) = -\frac{|PP'|}{|P''P'|}, k(Q) = +\frac{|QQ'|}{|Q''Q'|}, k(P'') = k(Q'') = 0. \quad (11)$$

7. Extenics Web Development.

Web Developer Mihai Liviu Smarandache worked for the Research Institute of Extenics and Innovation Methods, the Guangdong University of Technology, from Guangzhou, P. R. China, in August 2012, together with Prof. Cai Wen, Prof. Xingsen Li, Prof. Weihua Li, Prof. Xiaomei Li, Prof. Yang Chunyan, Prof. Li Qiao-Xing, Prof. Florentin Smarandache, Research Assistant Jianming Li, and graduate student Zhiming Li.

- a) He proposed the improvement of the Extenics website's layout to provide a better user experience. Currently, the Extenics website has many articles that the user can click on and that will show up on the page. If the user wants to save or print the articles they will have to copy and paste the article text into Microsoft Word and print.

The new layout gives the user the ability to click on the article and have it export directly to a *pdf* file for easy processing (saving/printing).

The new layout also provides a contact Extenics page where the user can send a direct email to the Extenics department.

- b) He proposed the including of an interactive Tutorial on Extenics, so more people around the globe learn about it. The tutorial can have games that the user can play as part of the

Extenics learning. The tutorial can also include tests to test the user to see how much they have learned.

- c) He proposed an Automatic Email Sending, such that when new Extenics publications, presentations, conferences, events occur an automatic email system will send the new information to all Extenics members.

He wrote the code and incorporated it into the Extenics control panel, but the *php* mail function was not supported. He checked the version of *php* installed on the server and it was 5.2, which is a very old version. He suspected that this could be the problem as to why the emails are not working.

- d) He also proposed a Calendar of Extenics Events to be incorporated to the Extenics website. This calendar can let an Extenics administrator add important upcoming events from a control panel. The user can visit the Extenics website and click on the calendar and view the events. If a user chooses to do so, the website can send email reminders about these events.

8. Extenics What-to-do List.

- So far there have been done applications of Extenics in one-dimensional space. Now there are needed generalizations of the applications of Extenics in $2D$, $3D$, and in general in $n-D$ spaces in all previous fields done in $1D$ space: i.e. in data mining, control theory, management, design, information theory, etc.

One has to use the $n-D$ extension distance between a point and a set, and the $n-D$ extension dependent function of a point with respect to a nested set without common ending points and with common ending points.

- Single infinite interval dependent function to be generalized from one-dimensional space to $2D$, $3D$ and in general $n-D$ spaces.
- Applications of Extenics if possible in new fields not yet approached in the one-dimensional space yet, such as: in physics, chemistry, biology, geology, etc.
- More software related to Extenics.
- Tutorials related to Extenics.
- Improving the Extenics website. Introducing the automatic email.

Also, adding more papers and books (especially in English) to the Extenics website.

Acknowledgement.

The authors bring their deep thanks to the professors (especially to Prof. Cai Wen, President of RIEIM), researchers, and students of the Research Institute of Extenics and Innovation Methods, from the Guangdong University of Technology, in Guangzhou, P. R. China, who sponsored their study and research on Extenics for three months (19 May – 14 August) and respectively half of month (1-14 August) during the summer of 2012.

References:

- [1] Qiao-Xing Li and Xing-Sen Li, *The Method to Construct Elementary Dependent Function on Single Interval*, Key Engineering Materials Vols. 474-476 (2011), pp. 651-654, www.scientific.net.
- [2] Florentin Smarandache, *Generalizations of the Distance and Dependent Function in Extenics to 2D, 3D, and n-D*, "Global Journal of Science Frontier Research (GJSFR)" [USA, U.K., India], Vol. 12, Issue 8, pp. 47-60, 2012;
and in "Progress in Physics", University of New Mexico, USA, Vol. 3, pp. 54-61, 2012.
- [3] Cai Wen. *Extension Set and Non-Compatible Problems* [J]. Journal of Scientific Exploration, 1983, (1): 83-97;
also Cai Wen. *Extension Set and Non-Compatible Problems* [A]. Advances in Applied Mathematics and Mechanics in China [C]. Peking: International Academic Publishers, 1990.1-21.
- [4] Yang Chunyan, Cai Wen. *Extension Engineering* [M]. Beijing: Science Press, 2007.
- [5] Wu Wenjun et al. "Research on Extension theory and its application" *Expert Opinion*. 2004, 2; <http://web.gdut.edu.cn/~extenics/jianding.htm>.
- [6] Y. Xu and Q.X. Zhu: *An intelligent operation optimization method for process industry based on extension theory and its application*. CIESC Journal, Vol. 60 (10) (2009), p. 2536-2542 (in Chinese).
- [7] X.R. Duan, Y.N. Yan and X.M. Zhu: *Synthetically evaluation of RMS based on extension theory*. *Machinery Design and Manufacture*, Vol. (1) (2010), p. 125-127 (in Chinese).
- [8] C.B. Li, Q.L. Wang and F. Liu, etc.: *Program design for green manufacturing implementation based on extension theory*. *China Mechanical Engineering*, Vol. 21(1) (2010), p. 71-75 (in Chinese).
- [9] W. Cai and Y. Shi: *Extenics: its significance in science and prospects in application*. *Journal of Harbin Institute of Technology*, Vol. 38(7) (2006), p. 1079-1087 (in Chinese).
- [10] J. Chen and S.Y. Zhang: *Product regenerative design based on tentative design chain*. *Computer Integrated Manufacturing*, Vol. 15(2) (2009), p. 234-239 (in Chinese).
- [11] Q.X. Li and S.F. Liu: *A method to construct the general location value and general elementary dependent function*. *Systems Engineering*, Vol. 24(6) (2006), p. 116-118 (in Chinese).
- [12] Q.X. Li and S.F. Liu: *The method to construct interval general elementary dependent function*. *Systems Engineering---Theory and Practice*, Vol. (6) (2007), p. 173-176 (in Chinese).
- [13] Q.X. Li: *The method to construct elementary dependent function based on infinite interval*. *Mathematics in Practice and Theory*, Vol. 39(4) (2009), p. 142-146 (in Chinese).
- [14] Q.X. Li and S.F. Liu: *The method to construct interval elementary dependent function based on the interval distance and side-distance*. *Journal of Harbin Institute of Technology*, Vol. 38(7) (2006), p. 1097-1100 (in Chinese).
- [15] C.Y. Yang and W. Cai: *Extension engineering* (Science Press, China 2007) (in Chinese).

Extention Transformation Used in I Ching

Florentin Smarandache
University of New Mexico
Mathematics and Science Department
705 Gurey Ave.
Gallup, NM 87301, USA
E-mail: smarand@unm.edu

Abstract.

In this paper we show how to using the *extension transformation* in *I Ching* in order to transforming a hexagram to another one. Each binary hexagram (and similarly the previous trigram) has a degree of *Yang* and a degree of *Yin*. As in neutrosophic logic and set, for each hexagram $\langle H \rangle$ there is corresponding an opposite hexagram $\langle antiH \rangle$, while in between them all other hexagrams are neutralities denoted by $\langle neutH \rangle$; a neutrality has a degree of $\langle H \rangle$ and a degree of $\langle antiH \rangle$.

A generalization of the trigram (which has three stacked horizontal lines) and hexagram (which has six stacked horizontal lines) to n -gram (which has n stacked horizontal lines) is provided. Instead of stacked horizontal lines one can consider stacked vertical lines - without changing the composition of the trigram/hexagram/ n -gram. Afterwards, circular representations of the hexagrams and of the n -grams are given.

1. Introduction.

“I Ching”, which means *The Book of Changes*, is one of the oldest classical Chinese texts. It is formed of 64 hexagrams.

In this paper we are referring to *I Ching* used in the Chinese culture and philosophy only, not the divinization. According to *I Ching* everything is in a continuous change.

At the beginning, between 2800-2737 BC, originating with the culture hero Fu Xi, there have been 8 trigrams, and within the time of the legendary Yu (2194-2149 BC) the trigrams were expanded into 64 hexagrams.

Each trigram was formed by three stacked horizontal lines. Then two trigrams formed a hexagram.

Therefore a hexagram is formed by six stacked horizontal lines; and each stacked horizontal line is either unbroken line (—), called **Yang**, or broken line (— —), called **Yin**.

Yang is associated with MALE, positive, giving, creation, digit 1, and Yin is associated with FEMALE, negative, receiving, reception, digit 0 in the Taoist philosophy. In Taoism, Yang and Yin complement each other, like in the *taijitu* symbol:



Figure 1

The number of all possible trigrams formed with unbroken or broken lines is $2^3 = 8$.

And the number of all possible hexagrams also formed with unbroken or broken lines is

$$2^6 = 64.$$

A hexagram is formed by two trigrams: the first trigram (first three lines) is called *lower trigram* and represents the inner aspect of the change, while the second trigram (last three lines) is called *upper trigram* and represents the outer aspect of the change.

2. Analyzing the Hexagrams

As in neutrosophy (which is a philosophy that studies the nature of entities, their opposites, and the neutralities in between them), we have the following for the *I Ching* hexagrams:

- To each hexagram $\langle H \rangle$ an anti-hexagram $\langle antiH \rangle$ is corresponding, and 62 neutral hexagrams $\langle neutH \rangle$ are in between $\langle H \rangle$ and $\langle antiH \rangle$.
- Each $\langle neutH \rangle$ has a degree of $\langle H \rangle$ and a degree of $\langle antiH \rangle$. The degrees are among the numbers $1/6, 2/6, 3/6, 4/6, 5/6$ and the sum of the degree of $\langle H \rangle$ and degree of $\langle antiH \rangle$ is 1.
- Let's note the 62 neutral hexagrams by $\langle neutH_1 \rangle, \langle neutH_2 \rangle, \dots, \langle neutH_{62} \rangle$. For each neutral hexagram $\langle neutH_i \rangle$ there is a neutral hexagram $\langle neutH_j \rangle$, with $i \neq j$, which is the opposite of it.
- For each stacked horizontal line the **extension transformation** is the following:

$$T: \{Yang, Yin\} \rightarrow \{Yang, Yin\}$$

$$T(x) = \bar{x}, \text{ where } \bar{x} \text{ is the opposite of } x,$$

i.e.

$$T(Yang) = Yin \text{ or } T(\text{————}) = \text{-- --}$$

and

$$T(Yin) = Yang \text{ or } T(\text{-- --}) = \text{————}$$

To transform a hexagram into another hexagram one uses this extension transformation once, twice, three times, four times, five, or six times. The maximum number of extension transformations used (six) occurs when we transform a hexagram into its opposite hexagram.

3. Hexagram Table.

The below Hexagram Table is taken from Internet ([1] and [2]); instead of stacked horizontal lines one considers stacked vertical lines - without affecting the results of this article.

In this table one shows the modern interpretation of each hexagram, which is a retranslation of Richard Wilhelm's translation.

Hexagram Table

Hexagram	Modern Interpretation
01. ☰☰ Force (乾 qián)	Possessing Creative Power & Skill
02. ☷☷ Field (坤 kūn)	Needing Knowledge & Skill; Do not force matters and go with the flow
03. ☳☳ Sprouting (屯 zhūn)	Sprouting
04. ☶☶ Enveloping (蒙 méng)	Detained, Enveloped and Inexperienced
05. ☱☱ Attending (需 xū)	Uninvolvement (Wait for now), Nourishment
06. ☱☲ Arguing (訟 sòng)	Engagement in Conflict
07. ☳☲ Leading (師 shī)	Bringing Together, Teamwork http://en.wikipedia.org/wiki/I_Ching_-_cite_note-ichdm-21
08. ☵☵ Grouping (比 bǐ)	Union
09. ☱☳ Small Accumulating (小畜 xiǎo chù)	Accumulating Resources
10. ☵☶ Treading (履 lǚ)	Continuing with Alertness
11. ☵☳ Pervading (泰 tài)	Pervading
12. ☶☶ Obstruction (否 pǐ)	Stagnation
13. ☱☱ Concording People (同人 tóng rén)	Fellowship, Partnership
14. ☰☷ Great Possessing (大有 dà yǒu)	Independence, Freedom
15. ☱☵ Humbling (謙 qiān)	Being Reserved, Refraining
16. ☱☲ Providing-For (豫 yù)	Inducement, New Stimulus
17. ☱☳ Following (隨 suí)	Following
18. ☱☲ Corrupting (蠱 gǔ)	Repairing
19. ☱☳ Nearing (臨 lín)	Approaching Goal, Arriving http://en.wikipedia.org/wiki/I_Ching_-_cite_note-cigic-23

20.  Viewing (觀 guān)	The Withholding
21.  Gnawing Bite (噬嗑 shì kè)	Deciding
22.  Adorning (賁 bì)	Embellishing
23.  Stripping (剝 bō)	Stripping, Flaying
24.  Returning (復 fù)	Returning
25.  Without Embroiding (無妄 wú wàng)	Without Rashness
26.  Great Accumulating (大畜 dà chù)	Accumulating Wisdom
27.  Swallowing (頤 yí)	Seeking Nourishment
28.  Great Exceeding (大過 dà guò)	Great Surpassing
29.  Gorge (坎 kǎn)	Darkness, Gorge
30.  Radiance (離 lí)	Clinging, Attachment
31.  Conjoining (咸 xián)	Attraction
32.  Persevering (恆 héng)	Perseverance
Hexagram	Modern Interpretation
33.  Retiring (遯 dùn)	Withdrawing
34.  Great Invigorating (大壯 dà zhuàng)	Great Boldness
35.  Prospering (晉 jìn)	Expansion, Promotion
36.  Brightness Hiding (明夷 míng yí)	Brilliance Injured
37.  Dwelling People (家人 jiā rén)	Family
38.  Polarising (睽 kuí)	Division, Divergence
39.  Limping (蹇 jiǎn)	Halting, Hardship
40.  Taking-Apart (解 xiè)	Liberation, Solution
41.  Diminishing (損 sǔn)	Decrease
42.  Augmenting (益 yì)	Increase
43.  Parting (夬 guài)	Separation
44.  Coupling (姤 gòu)	Encountering
45.  Clustering (萃 cuì)	Association, Companionship
46.  Ascending (升 shēng)	Growing Upward
47.  Confining (困 kùn)	Exhaustion

48. ☳☱ Welling (井 jǐng)	Replenishing, Renewal
49. ☳☷ Skinning (革 gé)	Abolishing the Old
50. ☳☵ Holding (鼎 dǐng)	Establishing the New
51. ☳☳ Shake (震 zhèn)	Mobilizing
52. ☳☶ Bound (艮 gèn)	Immobility
53. ☳☱ Infiltrating (漸 jiàn)	Auspicious Outlook, Infiltration
54. ☳☱ Converting The Maiden (歸妹 guī mèi)	Marrying
55. ☳☱ Abounding (豐 fēng)	Goal Reached, Ambition Achieved
56. ☳☱ Sojourning (旅 lǚ)	Travel
57. ☳☱ Ground (巽 xùn)	Subtle Influence
58. ☳☱ Open (兌 duì)	Overt Influence
59. ☳☱ Dispersing (渙 huàn)	Dispersal
60. ☳☱ Articulating (節 jié)	Discipline
61. ☳☱ Centre Confirming (中孚 zhōng fú)	Staying Focused, Avoid Misrepresentation
62. ☳☱ Small Exceeding (小過 xiǎo guò)	Small Surpassing
63. ☳☱ Already Fording (既濟 jì jì)	Completion
64. ☳☱ Not-Yet Fording (未濟 wèi jì)	Incompletion

4. Examples of Extension Transformations used for Hexagrams.

As an example of studying the above Hexagram Table, let's take the first hexagram and denote it by

$$\langle H \rangle = \text{☳☱}$$

Then its opposite diagram happened to be its second hexagram:

$$\langle antiH \rangle = \text{☳☷}$$

Their modern interpretation is consistent with them, since $\langle H \rangle$ means “Possessing Creative Power & Skill”, while $\langle antiH \rangle$ means the opposite, i.e. “Needing Knowledge & Skill” (because $\langle antiH \rangle$ doesn't have knowledge and skills).

Hexagram $\langle H \rangle$ is known as “Force”, while $\langle antiH \rangle$ as “Field”, or the Force works the Field.

As in Extenics founded and developed by Cai Wen [3, 4], to transform $\langle H \rangle$ into $\langle antiH \rangle$ one uses the extension transformation $T(Yang)=Yin$ six times (for each stacked vertical line). The other 62 hexagrams have a percentage of $\langle H \rangle$ and a percentage of $\langle antiH \rangle$.

There are:

$C_6^0 = 1$ hexagram that has $6/6 = 100\%$ percentage of $\langle H \rangle$ and $0/6 = 0\%$ percentage of $\langle antiH \rangle$;

$C_6^1 = 6$ hexagrams that have $5/6$ percentage of $\langle H \rangle$ and $1/6$ percentage of $\langle antiH \rangle$;

$C_6^2 = 15$ hexagrams that have $4/6$ percentage of $\langle H \rangle$ and $2/6$ percentage of $\langle antiH \rangle$;

$C_6^3 = 20$ hexagrams that have $3/6$ percentage of $\langle H \rangle$ and $3/6$ percentage of $\langle antiH \rangle$;

$C_6^4 = 15$ hexagrams that have $2/6$ percentage of $\langle H \rangle$ and $4/6$ percentage of $\langle antiH \rangle$;

$C_6^5 = 6$ hexagrams that have $1/6$ percentage of $\langle H \rangle$ and $5/6$ percentage of $\langle antiH \rangle$;

$C_6^6 = 1$ hexagram that has $0/6 = 0\%$ percentage of $\langle H \rangle$ and $6/6 = 100\%$ percentage of $\langle antiH \rangle$.

The total number of hexagrams is:

$$\sum_{k=0}^6 C_6^k = (1+1)^6 = 1+6+15+20+15+6+1 = 64.$$

For the following neutral hexagram (“Gorge”)

$$\langle neutH_{29} \rangle = \begin{array}{c} \text{||} \\ \text{||} \\ \text{||} \\ \text{||} \\ \text{||} \\ \text{||} \end{array}$$

its opposite is another neutral hexagram (“Radiance”)

$$\langle neutH_{30} \rangle = \begin{array}{c} \text{||} \\ \text{||} \\ \text{||} \\ \text{||} \\ \text{||} \\ \text{||} \end{array}$$

$\langle neutH_{29} \rangle$ can be obtained from the hexagram $\langle H \rangle$ by using four times the extension transformation $T(Yang) = Yin$ for the first, third, fourth, and sixth stacked vertical lines.

Hexagram $\langle neutH_{29} \rangle$ is $2/6 = 33\%$ $\langle H \rangle$ and $4/6 = 67\%$ $\langle antiH \rangle$.

$\langle neutH_{30} \rangle$ can be obtained from the hexagram $\langle H \rangle$ by using two times the extension transformation $T(Yang) = Yin$ for the second, and fifth stacked vertical lines.

Hexagram $\langle neutH_{30} \rangle$ is $4/6 = 67\% \langle H \rangle$ and $2/6 = 33\% \langle antiH \rangle$.

5. Circular Representation of the Hexagrams.

Shao Yung in the 11th century has displayed the hexagrams in the formats of a circle and of a rectangle.

We represent the hexagrams in the format of a circle, but such that each hexagram $\langle H_i \rangle$ is diametrically opposed to its opposite hexagram $\langle antiH_i \rangle$. We may start with any hexagram $\langle H_0 \rangle$ as the main one:

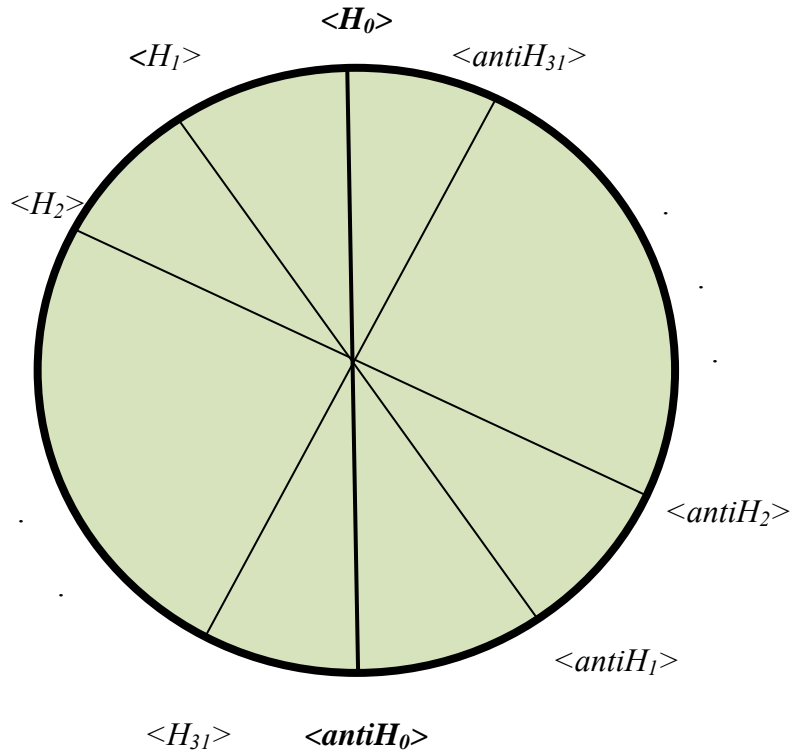

Figure 2

6. Generalization of Hexa-grams to n-grams.

The 3-gram (or trigram) and the 6-gram (or hexagram) can be generalized to an n -gram, where n is an integer greater than 1.

We define the n -gram as formed by n stacked horizontal lines; and each stacked horizontal line is either unbroken line (—), called **Yang**, or broken line (— —), called **Yin**.

Therefore we talk about binary n -grams.

The number of all possible binary n -grams is equal to 2^n .

Similarly to hexagrams we have:

- To each n -gram $\langle G \rangle$ an anti- n -gram $\langle antiG \rangle$ is corresponding, and $2^n - 2$ neutral n -grams $\langle neutG \rangle$ are in between $\langle G \rangle$ and $\langle antiG \rangle$.
- Each $\langle neutG \rangle$ has a degree of $\langle G \rangle$ and a degree of $\langle antiG \rangle$. The degrees are among the numbers $1/n, 2/n, \dots, (n-1)/n$ and the sum of the degree of $\langle G \rangle$ and degree of $\langle antiG \rangle$ is 1.
- Let's note the $2^n - 2$ neutral n -grams by $\langle neutG_1 \rangle, \langle neutG_2 \rangle, \dots, \langle neutG_{2^n-1} \rangle$. For each neutral n -gram $\langle neutG_i \rangle$ there is a neutral n -gram $\langle neutG_j \rangle$, with $i \neq j$, which is the opposite of it.
- For each stacked horizontal line the **extension transformation** is the same:

$$T: \{Yang, Yin\} \rightarrow \{Yang, Yin\}$$

$$T(x) = \bar{x}, \text{ where } \bar{x} \text{ is the opposite of } x,$$

i.e.

$$T(Yang) = Yin \text{ or } T(\text{————}) = \text{-- --}$$

and

$$T(Yin) = Yang \text{ or } T(\text{-- --}) = \text{————}$$

To transform an n -gram into another n -gram one uses this extension transformation once, twice, three times, and so forth up to $2^n - 2$ times. The maximum number of extension transformations used ($2^n - 2$) occurs when we transform an n -gram into its opposite n -gram.

To transform an n -gram $\langle G \rangle$ into its opposite $\langle antiG \rangle$ one uses the extension transformation $T(Yang)=Yin$ 2^n times (for each stacked vertical line). The other $2^n - 2$ n -grams have a percentage of $\langle G \rangle$ and a percentage of $\langle antiG \rangle$.

There are:

$C_n^0 = 1$ n -gram that have $n/n = 100\%$ percentage of $\langle G \rangle$ and $0/n = 0\%$ percentage of $\langle antiG \rangle$;

$C_n^1 = n$ n -grams that have $(n-1)/n$ percentage of $\langle G \rangle$ and $1/n$ percentage of $\langle antiG \rangle$;

$C_n^2 = n(n-1)/2$ n -grams that have $(n-2)/n$ percentage of $\langle G \rangle$ and $2/n$ percentage of $\langle antiG \rangle$;

·
·
·

$$C_n^k = \frac{n!}{k!(n-k)!} \quad n\text{-grams that have } (n-k)/n \text{ percentage of } \langle G \rangle \text{ and } k/n \text{ percentage of } \langle \text{anti}G \rangle;$$

·
·
·

$C_n^n = 1$ n -gram that has $0/n = 0\%$ percentage of $\langle G \rangle$ and $n/n = 100\%$ percentage of $\langle \text{anti}G \rangle$.

The total number of n -grams is:

$$\sum_{k=0}^n C_n^k = (1+1)^n = 1 + n + n(n-1)/2 + \dots = 2^n.$$

7. Circular Representation of the n-grams

We represent the n -grams in the format of a circle, but such that each n -gram $\langle G_i \rangle$ is diametrically opposed to its opposite n -gram $\langle \text{anti}G_i \rangle$. We may start with any n -gram $\langle G_0 \rangle$ as the main one:

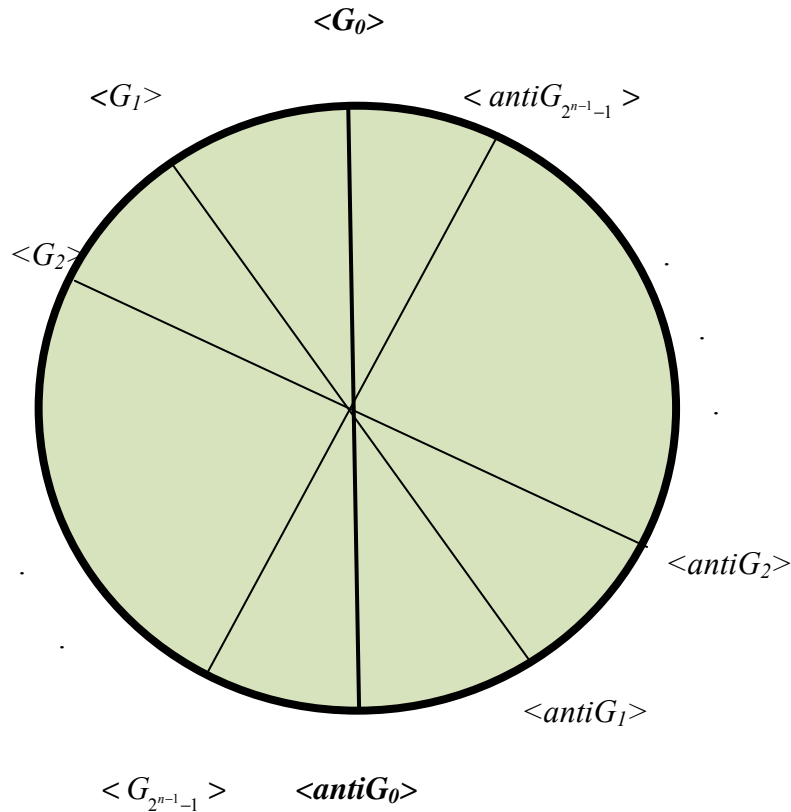

Figure 3

Conclusion

In this article the connection between *I Ching* (The Book of Change), Extenics, and neutrosophics has been made. Then a generalization from ancient trigrams and hexagrams to n -grams, $n \geq 1$, was presented at the end, together with the geometric interpretations of hexagrams and n -grams. An extension transformation is used to change from a hexagram to another one, and in general from an n -gram to another n -gram.

References

1. Wilhelm (trans.), Richard; Cary Baynes (trans.), "The I Ching or Book of Changes", from Internet.
2. *I Ching*, http://en.wikipedia.org/wiki/I_Ching
3. Cai Wen. Extension Set and Non-Compatible Problems [J]. Journal of Scientific Exploration, 1983, (1): 83-97.
4. Yang Chunyan, Cai Wen. Extension Engineering [M]. Beijing: Science Press, 2007.
5. F. Smarandache, Generalizations of the Distance and Dependent Function in Extenics to 2D, 3D, and n -D, *viXra.org*, <http://vixra.org/abs/1206.0014> and <http://vixra.org/pdf/1206.0014v1.pdf>, 2012.
6. F. Smarandache, V. Vlădăreanu, Applications of Extenics to 2D-Space and 3D-Space, *viXra.org*, <http://vixra.org/abs/1206.0043> and <http://vixra.org/pdf/1206.0043v2.pdf>, 2012.

Extensica în Conventional și Neconventional

Prof. Florentin Smarandache
Universitatea New Mexico
Gallup, NM 87301, SUA
E-mail: smarand@unm.edu

&

Ing. Tudor Păroiu
Coșoveni, Str. Linia Mare, nr. 29
Jud. Dolj, Cod 207205
Romania
E-mail: tudor.parioiu@yahoo.com

Semnificații

Extensica nu este altceva decât mult discutata interdisciplinaritate aplicată în practică care în realitate este studiu al simultaneității **entităților/univers**. Ea nu analizează doar două sau mai multe contrarii sau “rezolvarea problemelor contradictorii” ea studiază și încearcă rezolvarea simultaneității **entităților/univers**. Mai exact ea nu studiază doar contrariile ca elemente bipolare ci relația dintre două **entități/univers** nu neapărat contrare. Doi oameni, două fapte, două situații sau două fenomene (două **entități/univers** diferite), dar și continuitatea sau discontinuitatea acestora și nu neapărat contrarii. Trebuie revenit asupra categoriei filozofice de contrarie, trebuie să extindem această categorie la întreaga **transformare/spațiu/timp**. Dacă ținem cont de formulele domnului Smarandache vom constata că între limitele sale orice **transformare/spațiu/timp** este un raport de $\langle A \rangle / \langle \text{anti}A \rangle$ unde de data aceasta prin $\langle A \rangle$ și $\langle \text{anti}A \rangle$ nu mai definim contrariile ci limitele unei **transformări/spațiu/timp**. Și contrariile nu sînt altceva decât limitele transformării contrariei respective, respectiv ca exemplu trecerea de la pozitiv la negativ sau de la bine la rău. Și trecerea de la o transformare la alta este o contrarie sau dacă doriți trecerea de la o contrarie la alta este o transformare a raportului $\langle A \rangle / \langle \text{anti}A \rangle$ la fel cum se poate considera orice transformare în nelimitat. Tot ca exemplu putem defini contrarii și transformarea noastră de la existență la inexistență sau de la viață la moarte sau trecerea de la o autostradă cu circulația pe dreapta la una cu circulația pe stînga, etc. În „supa” descoperită în final în Elveția (care ar fi contrariile și care $\langle \text{neut}A \rangle$) ? toate

sînt unul și același lucru ca și într-o Gaură Neagră, sînt neconvenționale. Deocamdată neconvenționale pentru noi și cunoașterea noastră, pentru că nu putem încă să le definim **transformarea/spațiu/timp** sau contrariile (cum doriți), dacă reușim convenționalizarea lor ele devin convenții pur și simplu. Deoarece filozofii nu au înțeles corect legătura dintre **transformare/spațiu/timp** și contrarii ei au condiționat **transformarea/spațiu/timp** de contrarii. În realitate contrariile sînt însăși **transformarea/spațiu/timp** sau mai exact **transformarea/spațiu/timp** are un caz particular contrariile. Așadar contrariile sînt cazuri particulare ale **transformării/spațiu/timp**. Neconvenționalul merge dincolo de aceste convenții ale **transformării/spațiu/timp** și de cunoașterea noastră dincolo de „supa” amintită. Folosirea lui 0^* și ∞^* ca și al lui 0 și ∞ ne aduce mai aproape de realitate dar nu la

Realitatea în Sine, doar ne mărește limitele față de noi în nici un caz față de nelimitat.

Și neutrosafia poate face acest lucru prin extensie. Din acest motiv trebuie să înțelegem fenomenul filozofic adică în ansamblul lui și nu doar științific punctual, deoarece implicațiile nu sînt doar de natura unei științe ci general valabilă adică filozofic ca simultaneitate a tuturor științelor. De la fizică cuantică la medicină, biologie, fizică, chimie, tehnologie de orice natură, chiar literatură sau artă, etc. indiferent dacă cineva consideră că rezolvarea sau nu a unei probleme contradictorii nu implică toate științele, mai mult sau mai puțin. Am să dau exemplul cu autostrăzile cu benzi diferite ce trebuiesc unite. Poate spune cineva că acest lucru nu are implicație, socială, artistică, fizică, biologică, tehnologică, chimică sau chiar medicală de ce nu spirituală, etc.? să nu vă grăbiți, doar pentru faptul că nu înțelegem sau deocamdată nu vedem realitatea ci doar relativul ei nu putem nega lucrurile. Dacă ar schimba doar benzile de circulație este o soluție, o soluție convențională sînt însă și soluții neconvenționale și nu mă refer la posibilitatea modulării mașinilor astfel ca volanul să acționeze pe dreapta sau pe stînga în raport de necesități, eu privesc lucrurile mult mai neconvențional. Dacă oamenii ar putea să moduleze totul la nivel molecular sau chiar atomic sau ar putea ajunge la teleportare nu ar mai avea nevoie să modueze șoselele și nici oamenii. Poate că în viitor se poate modela omul și nu autostrada printr-o simplă schimbare de ochelari sau cine știe ce. Pentru că noi nu putem folosi realitatea în sine și aici trebuie să respectăm regula și să trucăm realitatea noastră pentru a păcăli Realitatea în Sine. Extensica este ca o trecere de la o filozofie teistă la una ateistă sau de la literatură la metematică sau în general de la o știință la alta. În natură și în realitate această trecere este perfectă pentru că este neconvențională și se face la nivelul **entităților/univers** neconvenționale simultan și imperceptibil, nu există element neutru în simultaneitatea neconvențională este ca nașterea sau moartea fiecăruia, noi nu știm nici cînd ne naștem dar nici cînd murim aceasta este trecerea neconvențională, o transformare ca trecerea de la copilărie la maturitate nu știi niciodată cînd se face. În convențional așa cum spuneți

și dumneavoastră este ca în neutrosofie, trebuie să inventăm un <neutA> care ține locul neconvenționalului din noi sau din Universul în Sine, (chiar dacă acest <neutA> este doar unul relativ și probabil) care face trecerea de la o contrarie la alta, în neconvențional aceste contrarii nu mai există sînt perfect simultane încît noțiunea însăși de contrarie devine absurdă. Autostrăzile cu siguranță vor avea un <neutA> este un truc al realității noastre. Dacă am fi neconvenționali mașina și individul s-ar adapta din mers și nu și-ar da seama decît cînd sînt pe cealaltă autostradă sau mai exact nu și-ar da seama niciodată pentru că neconvenționalul nu poate reflecta convențional. În Extensică este obligatorie neutrosafia și <neutA>, dacă nu există <neutA> trebuie să-l inventăm (așa cum am inventat cifra 0) ca pe un truc necesar al convenționalului la fel cum trebuie să facem cu orice **entitate/univers**, așa cum facem cu autostrăzile sau cum fac unii cu interdisciplinaritatea unde legăturile neconvenționale ale simultaneității dintre fizică și chimie (<neutA>) le spunem **chimie/fizică** chiar dacă niciodată nu vom putea defini limita exactă dintre ele. Analog **bio/chimie**, **bio/fizică**, etc. pentru oricare două științe veți găsi <neutA> respectiv o știință de graniță. Să nu credeți că între literatură și matematică nu este o știință de graniță, ea există dar nu am denumit-o noi încă. Toate cele prezentate sînt <neutA> convențional ales pentru neconvenționalul simultaneității **entităților/univers** sau mai exact Extensica lor. Din păcate sau poate din fericire dacă nu și una și alta simultan (deoarece în lipsa echilibrului respectiv <neutA> am înnebuni cu siguranță datorită instabilității și neputinței, ca și datorită lipsei celorlalte elemente obligatorii ale unei **entități/univers**) acest <neutA> există pentru noi special, în realitate este **pozitiv/negativul** simultan al celor două extreme doar că dimensiunile simultaneității sale (ale lui <neutA>) sînt din ce în ce mai mici tinzînd către 0. Elementele sale de **formă/existență/spirit** sînt foarte puțin perceptibile (reflectabile, convenționalizabile) pentru noi sau **entitățile/univers** care ne ajută. Acest <neutA> aparține domeniului numerelor foarte mici iar ca să fie o trecere (transformare) imperceptibilă trebuie ca elementele sale să fie dacă este posibil 0. Adică $0^* \gg 0$. La fel trebuie să fie și în ecuațiile matematice dacă se poate să fie nu doar în limitele $(0^*, 1)$ ci dincolo de 0^* cît mai apropiat de 0, în lumea numerelor foarte mici dintre 0 și 0^* , în același timp în care <A> și <antiA> să aparțină mulțimii (∞^*, ∞) adaptate cu un $\lambda(1)$ sau

cu ∞^* în raport de posibilitățile (trucurile) convențiilor noastre.

Mai întîi să introducem cititorul în lumea noilor convenții mai puțin convenționale decît toate cele anterioare, (niciodată însă neconvenționale în totalitate, neconvenționale doar față de cunoașterea noastră convențională) astfel vom introduce o serie de noi semnificații (0, 0^* , ∞^* , ∞) chiar dacă poate simbolurile rămîn aceleași. Oamenii fac

greșeala să încurce lucrurile, ei tind mereu să încurce realitatea lor (**iluzia/realitate**) cu Realitatea în Sine care nu le aparține fiind reflectată de spiritul lor doar prin intermediari (simțuri, logică, instinct, etc.) niciodată direct. Din acest motive eu am

introdus elemente ajutătoare (trucuri, 0, 0*, ∞*, ∞) convenționale ca să mă apropiez de realitate.

Dacă discutăm filozofic, în Universul în Sine nu există cifra 1, există doar 0 și cuantificările sau decuantificările acestuia. Cifra 0 în Universul în Sine ar trebui să fie inexistența dar ca paradox inexistența și existența sînt simultane pentru Universul în Sine în toate formele lui convenționale sau neconvenționale. Doar noi **entitățile/univers** ni se pare că intuim existența și inexistența separat și le convenționalizăm, separarea lor nu există ca realitate cum nu există nici cifra 0 sau 1. Cifra 1 (este relativă) nu există nici în convențional, doar multiplii sau submultiplii ei și diviziunile (aceste cifre sînt limite neconvenționale adică la nelimită) acesteia sau diverse cuantificări ale acesteia. 0 și 1 sînt limitele Universului în Sine adică nelimitatul lui perfectul existenței și perfectul inexistenței, paradoxal însă ele sînt simultane și la limita lor dispar ca noțiuni convenționale. Din acest motiv singurele limite pentru noi sînt cele convenționale respectiv 0* și ∞* (pe care le introduc eu) care în realitate nu sînt decît constante (înfinit de mari sau de mici) limitate ale oricărei simultaneități **transformare/spațiu/timp**. În acest caz orice **transformare/spațiu/timp**, pentru noi, este convențională, deci relativă, finită și constantă raportată la Universul în Sine. Mai mult dincolo de 0* și ∞* există limitele 0 și ∞ unde $(0^*, \infty^*) \in (0, \infty)$. Asta înseamnă simultaneitatea celor două domenii

de definiție în nici un caz identitatea lor. Cum orice **transformare/spațiu/timp** are un domeniu de definiție $(0^*, \infty^*)$ acest lucru implică simultaneitatea oricărei **transformări/spațiu/timp** convenționale cu cea neconvențională, dar și cu cele intermediare $(0n^*, \infty n^*)$. Această explicație ne arată că orice univers, orice **entitate/univers** și ca entitate și ca univers sînt simultane cu alte **entități/univers** (legea simultaneității). Atîta timp cît există un ∞* care respectă relația $0^* \infty^* = c$ există și un 0 care împreună cu nelimitatul (un 0 nelimitat de mic, deoarece și 0* este ∞* de mic ca să respecte relația $0^* \infty^* = c$) respectă relația $0 \infty = c$ diferența este că în timp ce în

convențional „c” poate lua valori în intervalul (0,1) dacă 0* și ∞* sînt simetrice (respective $0^* = 1/\infty^*$), în cazul $0 \infty = c$ nu există valori în afara intervalului (0,1) pentru „c”, singura lui valoare este 1, este unică la fel ca și 0 sau ∞.

Trebuie ținut cont permanent că între 0* și 1, ca și între 1 și ∞* sînt ∞* subdiviziuni convenționale iar în cazul nelimitatului, nelimitate subdiviziuni ca în realitate. De asemenea între 0* și 0 sînt nelimitate subdiviziuni ca și între ∞* și ∞. Acest lucru se datorează însă nu infinitului nostru convențional (∞*) sau lui 0* ci nelimitatului

∞ . Se pot lua nelimitate perechi de 0^* și ∞^* respectiv $(0_1^*, \infty_1^*)$, $(0_2^*, \infty_2^*)$, $(0_3^*, \infty_3^*)$...

$(0, \infty)$, etc. și fiecare are ∞^* variante la stînga și la dreapta lui 1 în raport de domeniul de

definiție al lui ∞^* (N, R, Q, C, etc.) și domeniile nou definite iau aceste valori. Adică între 0^* și 1 sînt numere raționale, complexe, etc. și între 1 și ∞^* sînt tot valori pe aceleași domenii de definiție dar și între 0_1^* și 1, sau 1 și ∞_1^* , sau între 0^* și 0_1^* sau ∞_1^* și ∞^* ș.a.m.d. pînă la 0 și ∞ . Limita acestui șir este nelimitatul lor iar ca produs este 1, toate

sînt simetrice față de 1. Singura lor diferență este gradul de multiplicare sau demultiplicare care se reduce la adunare și înmulțire cu și față de 1 și 0. Astfel orice număr dincolo de ∞^* este un număr cuantificat prin adunare sau scădere de 1, respectiv $\infty_1^* = \infty^* + \lambda(1)$ (indiferent de modelul funcției acestuia) unde λ reprezintă cuantificarea lui 1 prin adunare sau scădere de orice natură. Să nu uităm că înmulțirea sau orice operație este cuantificare prin adunare sau scădere de 1 și subdiviziunile acestuia. Calculatorul și sistemul binar al acestuia este exemplu edificator care rezolvă orice ecuație (fenomen, materie sau energie, etc.) prin multiplicare sau demultiplicare a lui 1 și 0. Dacă sîntem în lumea numerelor naturale atunci $\infty_1^* = \infty^* + 1$, ș.a.m.d. automat se poate calcula simetricul lui ∞_1^* sau valorile intermediare exterioare acestuia față de 0^* . În acest fel constatăm că orice mulțime de valori ale produsului lor din domeniul $(0_1^*, \infty_1^*)$ este valabilă și pentru domeniul $(0_1^*, \infty_1^*)$ dar și pentru domeniile $(0_1^*, 0^*)$ sau (∞^*, ∞_1^*) , diferența dintre ele este ordinul de cuantificare, între ∞_1^* și ∞^* dat de $\lambda(1)$. Unde λ poate lua toate valorile lui ∞^* . Putem spune astfel că orice valoare a lui ∞_1^* este o valoare a lui λ cuantificată cu ∞^* . Caz particular $\infty_1^* = \infty^* + R$ (mulțimea numerelor reale), pentru orice număr r există un $0_1^*(R)$. Pentru orice număr al lui R, 0_1^* are un corespondent ∞_1^* prin cuantificarea cu ∞^* și evident simetric al lui $0_1^*(R)$.

Ținînd cont de ceea ce am adus în prim plan pînă acum nu putem nega realitatea realității $0^* \infty^* = c$ dar nici pe cea a lui 0 unde $0 \infty = 1$ cu atît mai mult că nu putem nega

existența nelimitatului cum nu putem nega existența unui 0 ca nelimitat de mic. 0 și ∞

fiind limitele nelimitate ale lui 0^* și ∞^* . Să nu uităm un aspect important, să nu facem greșeala să credem că relațiile $0 = c/\infty$, sau $0 = 1/\infty$ sînt relații neconvenționale ele rămîn

convenționale sau mai exact neconvenționale pentru cunoașterea actuală dar nu neconvenționale adică nelimitate. În nelimitat aceste convenții devin absurde deoarece relația $0 \infty = 1$ dispare ca noțiuni sau sensuri iar la nelimitat 0 și 1 devin absurde. Să nu

uităm de asemenea că orice relație, funcție, formulă, etc. matematică sau de altă natură este o cuantificare sau decuantificare a lui 1 și 0 ca dovadă că orice operație este prelucrată de un calculator oricît de sofisticată ar fi iar calculatorul nu știe decît 0 și 1.

Ba mai mult o să constatăm că și sentimente sau energii sînt cuantificări de 0 și 1 și că această cunoaștere este energie care produce legături sau desface legături ceea ce este echivalent lui 0 și 1. Fenomenul este la fel și în creierul oricărei ființe raționale sau mai puțin raționale, doar că are alte energii și alte sisteme de numerație, de legături. În convențional 0^* sau ∞^* sînt de fapt o cuantificare sau decuantificare de 1, în timp ce în neconvențional cuantificarea este pentru 0 ceea ce ne spune că universul neconvențional este doar o multiplicare de 0 adică cuantificare de secvețe neconvenționale 0 în nelimitat. Diferența între om sau orice alte **entități/univers** și Universul în Sine este datorată energiei care produce procesarea datelor adică a vitezei în **spațiu/timp** în care se produce procesarea și modul procesării respectiv **transformarea/spațiu/timp** care produce această procesare. În spatele lor este doar energie în forme și legături diferite. După toată această teorie cred că putem spune că în lume numerelor foarte mici sau foarte mari putem lua un ∞^* (oricît de mare, dar niciodată nu va fi nelimitat) astfel încît dincolo de mulțime numerelor ($0^*, \infty^*$) să putem calcula un $\infty_1^* = \infty^* + \lambda(1)$, astfel încît să putem calcula un $0_1^* = 1/(\infty^* + \lambda(1))$ respectîndu-se relația $0_1^* \infty_1^* = 1$. Este o evidență că Universul în Sine ca și 0 sau nelimitatul sînt unice chiar dacă nu vom cunoaște niciodată limitele lui în ambele sensuri. Vrem nu vrem **entitățile/univers** sîntem și noi și toate sînt valori intermediare ale domeniului $(0, \infty)$ unde produsul lor este 1. 0 și ∞ sînt tot

constante dar paradoxal constante nelimitate (în timp ce ∞^* este un infinit limitat și constantă, ∞ este o constantă nelimitată) ceea ce în convențional nu se poate

convenționaliza, în plus acestea (0 și ∞) nu mai pot fi cuantificate dincolo de ele deși

avem tendința să credem acest lucru. Această relație $\lim 0^* \infty^* = 1$ cînd $0^* \gg 0$ și $\infty^* \gg \infty$ este o

axiomă care nu trebuie să necesite demonstrație și nici nu are demonstrație. Trebuie să țiem cont doar că această limită devine $0 \infty = 1$ sau $0 = 1/\infty$ relație valabilă în convențional.

O să spună unii că nu este obligatoriu 1 ci poate fi orice valoare c. Fals pentru că dacă în loc de 1 punem o altă valoare 0,1 spre exemplu acest lucru se traduce prin mărirea nelimitatului (reducere la absurd) ©, adică relația ar fi $0 = 1/10 \infty$ ceea ce presupune

mărirea nelimitatului, (0 ar trebui să devină și mai mic) în acest punct relația este absurdă pentru că nici 0 și nici ∞ nu mai sînt cuantificabile. Această relație este un

adevăr recunoscut dar nedemonstrabil și este relația generalizată între limitele oricărei **entități/univers** adică **transformare/spațiu/timp** și **formă/existență/spirit**. Un caz particular sîntem și noi oamenii pentru om 0^* este nașterea lui în timp ce ∞^* al lui este moartea lui și asemănător pentru fiecare parametru al său. Produsul lor este $c \in (0,1)$ pentru perioada existenței sale (perioada convențională) și 1 pentru limita existenței sale

cînd el devine **entitate/univers** constantă, finită și invariabilă în nelimitat. În acel moment toate variabilele lui devin constante mai mari sau mai mici dar invariabile definitiv. Omul devine atunci o unitate (**entitate/univers**) trecută. Pentru orice **entitate/univers** produsul $0^* \infty^* = c$ în timpul existenței dar la limita existenței sale devine 1. Așa cum am arătat în timpul existenței valorile pot depăși domeniul (0,1) pentru valori nesimetrice, în afara limitelor 0^* și ∞^* și nu în interiorul lor.

La fel ar fi și cu Universul în Sine dacă ar apare și dispere dar el nu are această posibilitate convențională el este neconvențional și 0 și 1 sînt simultane, noi doar convențional avem produsul limitelor sale 1, la limita lui toate elementele sale devin constante și invariabile și nu ar mai putea reveni la o nouă **entitate/univers** fiind nelimitat. (ar însemna să devină limitat) Relația $0 \infty = 1$ nu ar mai fi valabilă și s-ar

transforma în $0^* \infty^* = c$ ceea ce ar contrazice realitatea deoarece dincolo de 0 și ∞ nu mai

există, în realitate 0 și ∞ nu există pentru noi sau orice **entitate/univers** sînt doar o

extrapolare, ele sînt ceva ce noi nu vom putea defini niciodată. 0 și ∞ reprezintă

unicitatea, perfecțiunea universului în sine, nelimitatul lui, iar produsul lor **existența/inexistența** sa. 0 este o constantă nelimitat de mică, invariabilă, ∞ este

constantă nelimitat de mare invariabilă. Și 0^* și ∞^* sînt constante nelimitat de mici sau de mari pentru noi convențiile cît existăm dar după finalul existenței noastre adică în neconvențional ele devin clar finite. Cît existăm datorită variabilității noastre ni se pare că ele sînt variabile, în realitate noi nu le cunoaștem doar cei care ne urmează constată invariabilitatea lor după moartea noastră.

Legea acumulării și divizării sau legea $A^* + D^*$

Plecînd de la definiție Extensica {=rezolvarea problemelor contradictorii in orice domenii (rezolvarea problemelor inconsistente (contradictorii))} să ne oprim la soluțiile contradictorii din matematică. Toate cazurile de nedeterminare din matematică au corespondențe în orice știință sau neștiință ca și teoria lui 0^* și ∞^* . Grăbirea convențională (accelerarea convențională) se produce nu doar în matematică, fizică, chimie sau alte științe ci și în neștiințe ca și în natura cosmică. Exemplu formarea Big-Bang nu este altceva decît acumulări succesive de planete sau alte sisteme solare sau de altă natură. Apoi acest Big-bang de la acumulare a trecut la divizare (expansiune) a **materiei/energie** neconvenționale și nu doar în forma neconvențională ci și în formă convențională. De fapt Big-bangul era deja o **materie/energie** convențională dar nu pentru capacitatea noastră de cunoaștere actuală. Această **materie/energie** deja

convențională a accelerat procesul convențional formînd energii convenționale (multiplicări ale acumulărilor succesive cum sînt înmulțirea și împărțirea față de adunare sau altele) depășind limitele gravitației neconvenționale și creează planete, vegetație, apă, viață, etc. într-un ritm mult mai mare decît acumularea gravitațională. La fel și omul cu energiile sale convenționale accelerează fenomenele în mod convențional specific **entității/univers** om și elementelor sale **formă/existență/spirit** ca și elementelor acestora în raport de capacitățile lui convenționale sau de necesitățile lui convenționale. Reamintesc că orice număr este reprezentat de cifra unu și multiplii și submultiplii acesteia în convențional și de cifra 0 în neconvențional și că orice valoare a unei funcții indiferent de domeniul de definiție este un multiplu sau submultiplu al lui 1. Calculatorul este unul din cele mai sigure argumente deocamdată, el lucrînd doar cu 0

și 1 în timp ce Universul în Sine doar cu 0 plecînd de la relația $0 \times 1 = 1$, adică 1 este un multiplu nelimitat al lui 0 în neconvențional. Relație valabilă și în convențional dacă folosim relația $0^{\infty} = 1$. Și acest 1 este multiplu infinit de 0^* , mai mult trebuie să ținem cont că orice număr în orice sistem de numerație folosește aceleași simboluri (respectiv cifre) și ca atare multiplii și submultiplii ai lui 1. Pînă și cele 10 cifre de la 1 la 10 sînt multiplii sau submultiplii ai lui 1 iar în matematica convențională nu există alte cifre. Am definit în acest fel o nouă lege T^* , legea acumulării și divizării Universului în Sine, adică legea $A^* + D^*$ care se definește astfel:

- orice **entitate/univers** este acumulare sau divizare a lui 1 în convențional sau de 0 dacă vorbim de neconvențional.

Această lege are și formularea matematică prin relația $0 \times 1 = 1$, relație care se traduce prin faptul că un număr nelimitat de 0 (este vorba de un 0 neconvențional, nelimitat de mic, secvența neconvențională 0) de **entități/univers**, **entități/univers** 0 nelimitat de mici dau o unitate (o **entitate/univers** unitate 1). În particular relația devine convențională și se scrie $0^{\infty} = 1$, care ne spune același lucru dar folosește valori convenționale.

Cazuri particulare din matematică și neconvenționalul lor

Să analizăm cîteva cazuri de nedeterminare din matematică, $\infty - \infty =$ nedeterminat, $\infty / \infty =$ nedeterminat, sau $0/0 =$ nedeterminat, $0^{\infty} =$ nedeterminat, $0^0 =$ nedeterminat, $\infty^0 =$ nedeterminat și 1^n ($n = \infty$). Trebuie să aducem în discuție la aceste cazuri toate cazurile asimptotice ale funcțiilor care sînt de aceeași natură cu aceste cazuri nedeterminate. Dacă vom considera infinitul asimptotic (și nu ∞ , nelimitatul) un ∞^* atunci vom ști toate valorile funcției inclusiv pentru ∞^* . Desigur că există și valori dincolo de ∞^* dar acestea

ori nu ne interesează ori devin imposibil de determinat, ori dacă este nevoie extrapolăm valoarea lui ∞^* cu un $\lambda(1)$. Cazul parabolilor este evident în acest sens dar nu trebuie să ne oprim doar la parabolile matematice sau fizice sau chimice relația cu 0^* și ∞^* este valabilă oricărei parabole literare, sensibile, logice sau ilogice, științifice sau neștiințifice. Ca principiu general ar trebui modificat sistemul de coordonate în raport de 0 , 0^* , ∞^* și

∞ , astfel graficele ar putea fi în felul următor,

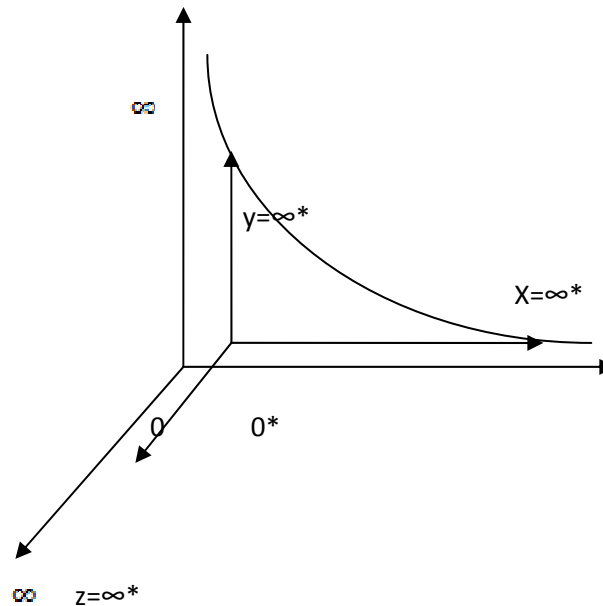

Unde $0^* \infty^* = 1$, iar $0 \infty = 1$.

- $\infty - \infty =$ nedeterminat, este o variantă neclară pentru că noi sîntem limitați și din acest motiv ∞ nu este nelimitat ci limitat, chiar dacă noi în intuiția noastră intuim

nelimitatul lui. De aceea revenim la semnificațiile introduse respectiv 0 , 0^* , ∞^* , ∞ , care definesc mult mai exact realitatea (chiar dacă nu Realitatea în Sine) și totodată extindem infinitul nostru limitat la nelimitat. În acest caz dacă înlocuim ∞ cu ∞^* rezultă relația $\infty_1^* - \infty^* = 0^*$ unde eroarea este dată de mărimea lui ∞^* și numai dacă cele două valori ∞_1^* și ∞^* sînt diferite, evident $\infty_1^* - \infty^* = 0^*$, unde toate cele trei valori sînt numere concrete convenționale iar relația este o realitate a noastră o realitate convențională. Fiind în convențional putem alege orice valoare pentru ∞_1^* și ∞^* iar diferența lor verifică relația

prezentată. Dacă ∞_1^* și ∞^* tind către ∞ este evident că diferența lor tinde către 0 neconvențional, nelimitat de mic și nici în acest caz nu putem verifica nedeterminarea lui.

- ∞/∞ , așa cum am arătat mai sus trebuie să facem diferențierea între posibilitățile noastre convenționale și neconvențional prin introducerea noilor convenții. În acest caz relația poate fi scrisă $\infty_1^*/\infty^*=1+a$, unde $a \in (0,1)$ dacă $\infty_1^* > \infty^*$ sau

$\infty_1^*/\infty^*=1-a$ unde $a \in (0,1)$ dacă $\infty_1^* < \infty^*$. În cazul în care ∞_1^* și $\infty^* \gg \infty$ relația devine $\infty/\infty=1$ dar totodată devine și imposibilă deoarece convențional dispare totul ca sens, chiar și sensurile.

- $0/0$, este analog lui ∞/∞ doar că relația devine $0_1^*/0^*=1+a$ unde $a \in (0,1)$ dacă $0_1^* > 0^*$ sau $0_1^*/0^*=1-a$ dacă $0_1^* < 0^*$. În realitate oamenii nu caută neapărat aceste valori convenționale ei caută nelimitatul pe care oricum nu îl vor găsi și chiar dacă prin absurd l-ar găsi acesta este dispărut în același moment.

- 0^0 , se transformă în $0^{*0^*}=a$ iar în acest caz devine o valoare determinată.

- ∞^0 , devine $\infty^{*0^*}=a$, de asemenea valori determinate și nu nedeterminate pe toată perioada existenței.

- 1^n , unde $n=\infty$. Caz nedeterminat oare de ce? Dacă $n=\infty^*$ atunci valoarea $1^n=1$ pentru orice n . Dacă mergem la limita lui 1^n către nelimitat doar la limită aceasta nu este 1 dar acolo nu mai este nimic sau este totul simultan pînă la desființarea

convențiilor de orice natură inclusiv 1 și ∞ .

- 0^∞ , în realitate relația convențională 0^∞ =nedeterminat nu este valabilă, sau este doar convențional valabilă dacă dorim să impunem acest lucru, deoarece raportul lor nu este o variabilă ci o constantă. În realitate $0^\infty=c$ unde c are valori în orice sistem de numerație și respectă relația $c/\infty=0$. Este greu să cred că nedeterminat/ $\infty=0$ mai ales

dacă nedeterminatul este ∞ sau 0 sau nelimitat, sau orice valoare între ∞ și ∞ , adică dincolo de infinit în nelimitat. Îl vom analiza un pic mai special plecînd de la relația

$0^{*\infty^*}=1$, care este o relație perfect valabilă atîta timp cît $0^* \neq 0$ și $\infty^* \neq \infty \neq \infty$ iar 0^* și ∞^* sînt simetrice față de 1, în aceste condiții există o funcție $f(x,y)=1$, unde $x=0^*$, iar $y=\infty^*$

care să verifice relația. Evident în aceste condiții $\infty^*/\infty=0$, dar și $c/\infty=0$, unde $\infty=$

nelimitat. În acest fel definim un 0^* și ∞^* care pot fi cuantificate cu orice $\lambda \neq 0$ și $\lambda \neq \infty$, care poate aparține, sau nu, intervalului $(0^*, \infty^*)$. Relația $0^* \infty^* = 1$ este un caz particular al relației $0^* \infty^* = c$ pentru că în matematică $0^* \infty^* = c$ sau $0^* \infty^* =$ nedeterminat dar acest nedeterminat este nedeterminat ca valori ale lui c și nu că c ar fi mai puțin constantă. Ținem cont în acest sens și de relația $0^* = c/\infty^*$, adică $0^* \infty^* = c$, întrucât $\infty^* \neq 0$, relație recunoscută de matematica noastră convențională. Este de asemenea evident că $0^* \in (0,1)$. În acest fel printr-un coeficient λ putem merge în lumea numerelor foarte mici, sau foarte mari. În orice structură, formulă, **entitate/univers**, convenție, trebuie introdus un coeficient care face parte din universul numerelor foarte mici sau foarte mari care să corecteze relația convențională și care să reprezinte relativul oricărei relații, legi, etc. Trebuie să plecăm de la faptul că orice număr convențional este format din cifra unu prin multiplicare sau demultiplicare adică prin adunare și scădere și nimic altceva. Singura diferență este că această multiplicare (adunare și scădere) se poate grăbi (convențional) prin artificii de înmulțire și împărțire sau alte operații și funcții, dar toate absolut toate pleacă de la ceea ce v-am prezentat. În neconvențional toate cifrele și relațiile îndiferent de știință pleacă de la cifra 0. Adică cifra 1 este o sumă nelimitată de

cifre 0 ($0 \infty = 1$ este adevărată) sau în convențional este o multiplicare a lui 0^* cu ∞^* , respectiv $0^* \infty^* = 1$. Orice sistem de numerație pleacă de la acest număr și putem scrie fără dubii că mulțimea numerelor naturale N este de fapt $N = 1 + N^*$ sau $N = 1 + \infty^*$ unde $\infty^* \in N^*$ ($N^* = N - 1$). În acest fel se poate scrie că orice sistem de numerație dincolo de ∞^* pleacă de la ∞^* la care se adaugă un număr nelimitat de alte diviziuni evident dintr-un sistem de numerație sau altul. 0^* și ∞^* teoretic nu mai sînt nedeterminate dacă le-am considerat diferite de 0 sau de ∞ , ele au o valoare bine determinată dar nu le știm valoarea și pot lua o mulțime de valori ceea ce în convențional este mai greu. Să presupunem că $0^* = 1/a$ unde $a \neq (0,1)$, în acest caz există un număr $\infty^* = a$ astfel ca $0^* \infty^* = 1$. Dacă luăm un șir de valori ale lui 0^* și ∞^* , respectiv $0n^*$ și ∞n^* , obținem un șir de limite ($0n^*, \infty n^*$) cu relația dintre ele $0n^* = 1/(\infty^* + n)$ și $\infty n^* = \infty^* + n$ (n poate fi natural, real, rațional, etc.) asta implică faptul că pentru orice $0n^*$ există un $\infty^* + n$ ca relația să rămîină valabilă. Asta presupune că pentru intervalul $0n^*$ și ∞n^* există limitele 0,1 al produsul lor, limite între care putem lua orice valoare pentru $0n^*$ și ∞n^* . Trebuie să remarcăm faptul că atît $0n^*$ cît și ∞n^* nu sînt valori variabile ci constante chiar dacă ele sînt infinite către mărime nelimitată sau către un 0 nelimitat de mic. Aceste valori sînt limitele finite ale unei **entități/univers** (om, calculator, telescop, planetă, etc.) Filozofic vorbind produsul existențial de la nașterea unei **entități/univers** (0^*) pe toate direcțiile cu limita infinitului său (∞^*) este 1 în realitatea convențională dar și la limita lor neconvențională în condițiile enunțate mai sus. Doar pentru Universul în Sine valoarea produsului $0 \odot = 1$

în orice condiții, în timp ce pentru orice valoare mai mică de ∞ produsul este între (0,1)

indiferent cât de mari sau de mici sînt valorile 0 și ∞ . În Universul în Sine produsul $0^* \infty^* = 1$ este cuprins între (0,1). De aici pînă la matematica neconvențională mai avem un pas, vorbind de neconvenționalul cunoașterii noastre și nu de neconvenționalul în sine. Putem scrie relația $0^* \infty^* = c$ unde $c \neq (0,1)$ doar dacă în realitate putem presupune un ∞^* nesimetric față de 1, în acest caz valoarea produsului este mai mare sau mai mică decît 0 sau 1. Dacă $\infty^* \neq \infty^*$ acesta poate fi $\infty^* = \infty^* + a$ sau $\infty^* = \infty^* - a$, pentru orice $a \in \mathbb{C}$. În acest caz $0^* \infty^* = 1$ devine $0^*(\infty^* - a) = 1$, adică $0^* \infty^* = 1 + a0^*$. (toate operațiile sînt valabile pentru că toate numerele sînt diferite de 0). După această explicație putem spune că între simetricele 0^* și ∞^* produsul lor este între 0 și 1. Adică $c \in (0,1)$ pentru $0^* \in (0,1)$ în timp ce dacă $0n^* = 0^* + a$, atunci din relația $0n^* \infty^* = c$ rezultă $a = (c-1)/\infty^*$ mai mic decît 1. Între 0 și 1 sînt nelimitate subdiviziuni dar și în afara lor întrucît nu putem lucra cu nelimitatul ne vom opri întotdeauna la un limitat 0^* și ∞^* care sînt valori cuantificabile care se pot extinde dincolo de numerele mari sau mici actuale. Relațiile rămîn valabile ca extrapolare și în neconvențional dar este doar o ipoteză niciodată verificabilă pentru că nelimitatul nu ne aparține. Padoxal însă în nelimitat existența și inexistența nu pot fi depășite iar ele reprezintă 0 și 1 neconvențional, nelimitate, adică dincolo de orice 0^* și

∞^* există un singur Univers în Sine. Relația 0∞ nu este niciodată 0 și nici valori între 0 și

1 pînă la limita nelimitatului ∞ și al lui 0, care de fapt ca un paradox nu există (devin absurde ca noțiuni convenționale). La valori nesimetrice intermediare limitelor lor (deoarece produsul lor nu permite existența nesimetrică a unuia dintre ele în afara lor) produsul lor nu poate fi decît 1 pentru orice valoare conform demonstrației anterioare. Dovada este însăși existența **entităților/univers** și nelimitatul lor ca număr, formă etc.

cu probabilitate de apariție $1/\infty$ și posibilă doar datorită relației $0 \infty = 1$. Este însă inutil să vorbim convențional de neconvențional motiv pentru care ne oprim la relația $0^* \infty^* = 1$ și la convențiile noastre. Preluînd aceste lucruri filozofic vom constata că orice realitate convențională respectă această regulă și să urmărim sentimentele care deși au valori de la 0^* la ∞^* ele sînt un singur sentiment sau orice univers este o singură entitate simultan. Sentimentele, existența, forma, etc. sînt acest nedeterminat c cu valori între 0^* și ∞^* dar în același timp nu depășesc valoarea 1 în condiții de simetrie ci doar anomalia lor face valori dincolo de 0 și 1. Noi sîntem valorile nedeterminate ale Universului în Sine la fel cum pentru noi sentimentele noastre sînt aceste valori nedeterminate. Toate aceste

valorii convenționale sînt constante și limitate (bine determinate ca **transformare/spațiu/timp** și **formă/existență/spirit** față de Universul în Sine) chiar dacă

noi nu sesizăm acest lucru. $0/0$ nedeterminat mi se pare improprie pentru că în Universul în Sine nimic nu este nedeterminat față de Universul în Sine **entitățile/univers** sînt nedeterminate pentru noi sau alte **entități/univers** dar nu pentru Universul în Sine. Este greu de acceptat și pentru că este mai greu de acceptat relația

nedeterminat/ $0/0=0$ mai ales cînd nu știi valoarea nedeterminatului care poate fi însăși $0/0$ și în acest caz cu siguranță nu mai respectă relația convențională. Dacă însă nedeterminatul este o valoare constantă inclusiv ∞^* atunci relația devine logică în convențional. Chiar și în cazul $c/\infty^*=0^*$ pentru că este o convenție iar relația este logică în convențional. Unii poate vor pune la îndoială logica ei dar atît timp cît 0^* și ∞^* sînt valori simetrice relația este valabilă indiferent cît de mari sau de mici sînt aceste valori. A nu se confunda valoarea c cu viteza luminii. Aceste valori aparent sînt variabile dar variabilul lor este de fapt datorat nouă care sîntem variabili și nu acestor valori constante ca și în cazul mișcării cînd ne mișcăm noi avem senzația că se mișcă obiectele care stau pe loc, (în relativitatea absolută chiar nu se știe cine stă și cine se mișcă) noi și convențiile noastre sîntem relativi și nu Universul în Sine neconvențional și nelimitat și invariabil, adică perfect. Noi sîntem imperfecțiunea perfecțiunii fără de care nici perfecțiunea nu ar exista dar nici invers. În concluzie raportul $c/0=0$ nu este real pentru

noi ci corect este $1/0=0$, dar nici $\infty^*/0=0$ sau $c/\infty^*=0$ nu sînt corecte, ele ne arată totodată

un singur lucru că produsul $0^*\infty^*$ sau $0/0$ nu este nedeterminat ci o valoare constantă

nedeterminată adică $0^*\infty^*=c$ sau $0/0=1$. Această constantă reprezintă **entitățile/univers** din Universul în Sine și valori între 0 și 1 sau raportate într-un fel sau altul la 0 și 1 cu

probabilitatea logică de $1/\infty^*=0^*\neq 0$ sau $1/0=0$.

Lumea realității noastre convenționale (iluzierealitate) este aceasta, adică cea cuprinsă între 0^* și ∞^* , aceasta este de fapt realitatea cunoașterii noastre și a existenței noastre spirituale indiferent ce credem sau ce spunem noi sau alte **entități/univers**. Din împlinire această realitate este simultană cu o Realitate în Sine dar și cu o realitate în care există 0 ca și nelimitatul, adică și ceea ce există dincolo de 0^* și ∞^* și ambele suprapuse (simultane) cu o lume nelimitată în care toate convențiile noastre sau ale

oricărei **entități/univers** chiar dacă există nu mai pot fi reflectate convențional de nici o

entitate/univers deoarece 0 și ∞ devin unul și același lucru simultan asemănător cifrei 0 care este și pozitivă și negativă în același timp în care nu este nici pozitivă nici negativă, nemaiputând face o astfel de interpretare. Aceste relații interpretate filozofic ne spun ceea ce ne spune și realitatea, că dincolo de limitele noastre adică între 0^* și 0 sau între ∞^* și nelimitat sînt alte limite $0n^*$ și ∞n^* cu nelimitate subdiviziuni și variante și **entități/univers** dar diferite în același **timp/spațiu** (cuantificate în plus sau minus, **pozitiv/negativ**) și tot așa merg în nelimitat indiferent cît de mare sau de mic este infinitul nostru convențional. (∞^*)

O funcție **entitate/univers**

Să ne imaginăm o funcție pentru orice **entitate/univers**, este clar că nu putem să producem o funcție care să înlocuie perfect o **entitatea/univers** și că trebuie să ne folosim de trucurile convenționale ca în cinematografie (cele 24 de imagini) sau în matematică multiplicarea rapidă sau demultiplicarea rapidă (respectiv înmulțirea și împărțirea sau alte funcții), în pictură perspectiva, în literatură imaginile fowlkneriene dar care sînt o mulțime și în fizică, chimie, etc. În cinematografie știm că mișcarea să redă prin succesiunea rapidă a 24 sau mai multe imagini, în pictură perspectiva este dată prin linii carea pleacă dintr-un punct iar paralelismul prin linii care se intersectează dincolo de peisaj, în matematică orice operație în afară de adunare este un truc, o cuantificare rapidă cum spun eu în încercarea de a scurta timpul sau spațiul sau transformarea, în fizică se fac modele mecanice, electrice sau de altă natură pentru studiul fenomenelor în timp și spațiu chiar dacă știm că nu sînt realitatea în sine. Și în cazul nostru trebuie să găsim un truc filozofic (un model de funcție) dar să și ținem cont că singura legătură dintre transformările a două **entități/univers** este cuantificarea sau decuantificarea adică în convențional adunarea sau scăderea în variantele lor convenționale diverse. În acest fel orice relație matematică sau fizică sau de altă natură nu trece una la alta decît prin cuantificare sau decuantificare. Dar să trecem la funcția noastră unde cea mai complexă legătură și care doar aparent redă simultaneitatea (ca și adunarea și scăderea care aparent dau simultaneitate) este funcția funcției adică $F[fn(x)]$

unde $n \gg \infty$ iar $x \gg \infty$. Plecînd de la această variantă să ne imaginăm o **entitate/univers** ca o combinație de două funcții $E[fn(x,y,z)]U[fn(\alpha,\beta,\gamma)]$ unde U este universul iar E este entitatea iar x =forma, y = existența, z =spiritul, α =transformare, β =spațiu, γ =timp . La rîndul lor fiecare din aceste variabile sînt funcții compuse de alte variabile respectiv $x=f(a_1, b_1, c_1, .. etc.)$ unde $a, b, c, .. etc.$ = parametrii formei, $y=f(a_2, b_2, c_2, .. etc.)$ unde $a_2, b_2, c_2, .. etc.$ = parametrii existenței (gol, plin) iar $y=f(a_3, b_3, c_3, .. etc.)$ unde $a_3, b_3, c_3, .. etc.$ =

parametrii spiritului (memorie, gândire, intuiție, instinct, etc.). Toate aceste funcții și parametrii merg în nelimitat în funcție de alți parametri și alte funcții dar noi fiind în convențional ne putem opri la o convenție acceptată la care vom adăuga o funcție de corecție $f(\lambda)$ iar $\lambda = \lambda(1)$ care să reprezinte corecția și evident aparținând lumii numerelor foarte mici, adică relativul **entități/univers** datorat parametrilor necunoscuți interiori sau exteriori și această funcție nu trebuie să lipsească de la nici o **entitate/univers**. Această funcție rămîne o convenție, limitată și relativă pe care în raport de convențiile noastre o putem neglija sau nu. Plecînd de aici și încadrînd orice **entitate/univers** în limitele ei de existență adică 0^* și ∞^* pentru orice parametru, ținînd cont că valorile simetrice în intervalul 0^* și ∞^* pot fi stabilite avem o imagine truca a unei **entități/univers**. Această funcție adaptată pentru fiecare **entitate/univers** în parte o putem utiliza pentru rezolvarea contradicțiilor ei sau cel puțin pentru depistarea punctelor sensibile în raport de fiecare parametru **pozitiv/negativ**. Lumea acestor parametri este cea prezentată în schema neconvențională a parametrilor unei **entități/univers**. Cu o astfel de funcție putem determina elementele ei neutre în raport de **spațiu/timp** sau de elementele lor de comparație limitate în raport de relativul acestei funcții $f(\lambda)$. Realitatea ne spune de la început că această funcție trebuie să fie o simultaneitate **finit/infinită** de funcții limitate și relative în timp ce funcția $f(\lambda)$ deși limitată la lumea numerelor foarte mici ea este nelimitată ca diviziuni.

Lumea reală în raport de $\langle A \rangle$ și $\langle \text{anti}A \rangle$.

Realitatea noastră dar și realitatea în sine sînt o simultaneitate de $\langle A \rangle$ și $\langle \text{anti}A \rangle$ iar $\langle \text{neut}A \rangle$ nu există decît convențional, teoretic $\langle \text{neut}A \rangle$ este tot o simultaneitate de $\langle A \rangle$ și $\langle \text{anti}A \rangle$, un $S[\langle A \rangle / \langle \text{anti}A \rangle]$ unde $\langle A \rangle$ și $\langle \text{anti}A \rangle$ au valori **pozitiv/negative** în permanență, convențional spus. În neconvențional $\langle \text{neut}A \rangle$ nu există dar ca orice paradox totul este un $\langle \text{neut}A \rangle$ ca o simultaneitate de $\langle A \rangle$ și $\langle \text{anti}A \rangle$. Adică să nu ne facem nici o iluzie că dacă raportul $\langle A \rangle / \langle \text{anti}A \rangle = 0,99$ cele două sînt separate sau că una din ele nu există, atîta timp cît există un raport există simultaneitatea lor. $\langle \text{neut}A \rangle$ nu există dar aparține oricărei valori ale raportului $\langle A \rangle / \langle \text{anti}A \rangle$, adică filozofic convențional și neconvențional $\langle \text{neut}A \rangle$ nu există dar face parte din orice raport $\langle A \rangle / \langle \text{anti}A \rangle$ al oricărei **entități/univers** inclusiv formule matematice, fizice, chimice, etc. ca și în neutrosomie simultaneitatea lui $\langle A \rangle$ și $\langle \text{anti}A \rangle$. Orice fenomen convenție are o reprezentare matematică, fizică, chimică, etc. adică o filozofie matematică, chimică, etc. ca și o filozofie generală **entitate/univers** ca dovadă că în principiu pe calculator se poate studia orice fenomen sau transformare, mai bine sau mai puțin bine în raport de capacitatea convențiilor noastre. Aceste reprezentări sînt funcții de $\langle A \rangle$ și $\langle \text{anti}A \rangle$, necunoscutele lor sînt și ele simultaneități de $\langle A \rangle$ și $\langle \text{anti}A \rangle$ (ca orice **entitate/univers**). $\langle A \rangle$ și $\langle \text{anti}A \rangle$ au același domeniu de definiție, deoarece $A \in (0^*, \infty^*)$ iar $0^* \infty^* = 1$ dar și $\langle \text{anti}A \rangle \in (0^*, \infty^*)$, ținînd cont că în afara lui $\langle A \rangle$ nu există $\langle \text{anti}A \rangle$ în acest caz rezultă

același domeniu de definiție iar $0^* \infty^* = 1$. A crede că există un $\langle \text{antiA} \rangle$ în afara domeniului de definiție al lui $\langle A \rangle$, este ca și când am spune că poate exista lumină fără întineric sau **entități/univers** fără materie sau fără energie sau pozitivul fără negativ, sau o singură latură a oricărei contrarii, etc. În acest caz $\langle \text{neutA} \rangle$ este un element de simetrie în raportul dintre $\langle A \rangle$ și $\langle \text{antiA} \rangle$ cum este 1 pentru produsul limitelor lor ceea ce putem spune că 1 este simetricul lui $\langle A \rangle$ și $\langle \text{antiA} \rangle$ respectiv $\langle \text{neutA} \rangle = 1$. Doar 1 este neutru și față de $\langle A \rangle$ și față de $\langle \text{antiA} \rangle$ în raportul dintre ele adică $\langle A \rangle / \langle \text{antiA} \rangle = 1 = \langle \text{neutA} \rangle$. Depinde de noi unde situăm această valoare a lui 1 pe axa dintre ele. Nu putem spune că valarea raportului este 0 sau poate fi zero niciodată deoarece valoarea fiecăreia este diferită de 0 ca să existe, chiar dacă și 0 poate fi un neutru pentru **pozitiv/negativ** de exemplu dar nu ca produs ci ca adunere ceea ce noi nu comentăm momentan. Este evident că pentru orice valoare $c \in (0^*, \infty^*)$ produsul $0^* c = a < 1$. Încă un argument că limita intervalului adică ∞^* verifică relația $0^* \infty^* = 1$. Pentru a demonstra că $a < 1$ este suficient să luăm un $0^* < \infty^* < \infty^*$ pentru care relația noastră devine $0^* \infty^* = a$, dar $\infty^* = \infty^* - k$, unde $0^* < k < \infty^*$ ceea ce duce la $0^* (\infty^* - k) = a$ de unde rezultă $1 - k 0^* = a$ ceea ce evident ne confirmă ipoteza deoarece și 0^* și k sînt numere diferite de 0, dacă ar fi 0 $a = 0$ adică $\infty^* = \infty^*$. În raport de acest element de echilibru fiecare valoare are un simetric în intervalele respective, nu numai atît toate elementele unei **entități/univers** respectă această regulă a simetriei limitelor sale. În mod convențional putem alege alte valori pentru simetrie dar toate sînt doar cuantificări ale lui 1 și al simetricelor acestuia. În matematică acest $\langle \text{neutA} \rangle$ există ca și în alte științe sau neștiințe dar nu există ca realitate neconvențională.

Noi și limitele noastre convenționale

Poate unii o să ne spună că viața unui om pleacă de la 0 și se termină ca exemplu la 50 de ani și că produsul limitelor sale este ori 0 ori nedeterminat ori 50, în nici un caz 1. Cu părere de rău le spunem că pe de o parte niciodată omului nu-i putem determina cu precizie de 100% anul nașterii sau al morții (nu există sistem de măsurare perfect) iar pe de altă parte condiția de bază este ca cele două valori să fie simetrice și să acceptăm o anumită eroare convențională (eroare care ne redă relativul convenției). Simetricul lui 50 este $1/50$, adică $0,02$. Eroarea fiind de $(0-0,02)/50 = 0,0004$ față de 0. În plus ca realitate nașterea (ca și mortea) nu există, este o transformare continuă. Valorile sînt relative ca orice valoare convențională. Din cauza acestor motive putem convențional alege oricînd un 0^* în raport de ∞^* (50 de ani) astfel ca relația să fie valabilă în raport de eroarea pe care o dorim sau o acceptăm. În condițiile noastre relative $0^* \in (-1,0)$ sau $0^* \in (0,1)$ iar $50 = \infty^* \in (49,50)$ sau $(50,51)$. Trebuie însă luat în calcul că vorbim de valori convenționale mici sau mari dar nu de valori convenționale foarte mici sau foarte mari care se pot obține prin multiplicarea domeniului $(0^*, \infty^*)$ cu orice $\lambda(1)$. În cazul numerelor foarte mici sau foarte mari echivalența se menține dar eroarea se micșorează. În cazul numerelor

mici sau mari vorbim de numere dar la numere foarte mici sau foarte mari vorbim doar de simboluri ale numerelor. Orice **entitate/univers** nu poate să-și cunoască simetria deoarece nu-și atinge limitele și ca atare nu poate face produsul lor, valabil și pentru Universul în Sine. Ținând cont că orice convenție, **entitate/univers** este definită de domeniu de definiție, limite, elemente de echilibru și de comparație fiecare din aceste elemente are propria-i determinare și ca atare propriile limite la care produsul lor simetric este 1. Limitele oricărui parametru sînt definite de $0^* \in (0, 1)$ și $\infty^* \in (1, \infty)$ sau mai exact intervalului $\infty^* \in (\infty^* - 1, \infty^*)$ sau $(\infty^*, \infty^* + 1)$, adică respectă regula neutrosifică a lui Smarandache respectiv $\infty^* \in (\infty^* - \varepsilon, \infty^* + \varepsilon)$ iar $0^* \in (0, 1)$, 0 și 1 echivalentele lui $0^* + \varepsilon$ și $0^* - \varepsilon$. Trebuie supus unei analize această relație deoarece folosim un ε dar în realitate relația este $\infty^* \in (\infty^* - \varepsilon_1, \infty^* + \varepsilon_2)$ și doar în cazuri particulare $\varepsilon_1 = \varepsilon_2$. În realitate niciodată nu este valabilă relația $\varepsilon_1 = \varepsilon_2$ pentru că atunci ar putea fi determinat orice număr în mod perfect și nu relativ știind că este media domeniului său.

Energie neconvențională

Singura energie nelimitată este gravitația de fapt nu gravitația ci o forță de atracție care se transformă convențional în gravitație. Dovada celor spuse de mine ste însăși acea supă descoperită în Elveția unde sînt convins că deși nu mai putem separa convențional energia de materie este și energie și materie iar materia este sub atracția unor energii necunoscute încă. Această atracție este echivalentul acumulării universale în timp și spațiu și vinovatul existenței oricărei transformări în Universul în Sine. Trebuie să ținem cont și de contrariul ei respectiv respingerea sau echivalentul descompunerii al împingerii materiei în afara ei echivalent al convenționalei pierderi sau scăderi din matematică. În termeni astronomici contracția universului și expansiunea lui. Orice **entitate/univers** este efect al acestei acumulări și energiei ei neconvenționale sau în termeni convenționali simultaneitate **materie/gravitație**. Nimic nu s-a format în univers fără gravitație chiar și energiile convenționale respectiv electrică, magnetică, atomică, etc. dacă ne gîndim că mai întîi trebuiau să se acumuleze particulele neconvenționale la care nu se mai poate vorbi de energiile noastre convenționale și nu doar atît nu putem vorbi de energie atomică dacă atomii nu există ca și de un cîmp magnetic dacă acești atomi nu mai există ca în „supa” domnilor din Elveția. **Entitățile/univers** neconvenționale gravitaează în Universul în Sine în formă convențională și neconvențională în mod liber, acumularea lor este în timp și spațiu nelimitat iar după o acumulare suficientă această simulatneitate produce materii și energii convenționale. În final aceste **entități/univers** de **materie/energie** (convenționale) prin acumulări succesive (convenționale sau neconvenționale) sau diviziuni ajung din nou **entități/univers** neconvenționale în stadiu liber nelimitat de mici sau de mari. Trebuie să ne punem întrebări neconvenționale și să ne depășim propriile limite să nu credem că energiile sînt finite, să nu credem că ceea ce cunoaștem

este Realitatea în Sine să nu credem că Big-Bangul este ultima frontieră, limita, când de fapt pînă acum nu am găsit limită nici măcar în interiorul atomului. Orice formă de organizare nu s-a format din inexistență, nici măcar din vid, ci pe o acumulare neconvențională **materie/energie** care este în același timp **materie/energie** convențională și neconvențională. O **materie/gravitație** dincolo de capacitatea noastră de convenționalizare. Crede cineva că planetele sau Big-Bangul sau Găurile Negre sînt posibile fără gravitație? Se înșeală. Crede cineva că ar fi apărut viață sau forme de organizare fără gravitație (indiferent cît de mare sau de mică)? Se înșeală. Crede cineva că ar fi existat existență fără acumulare? Se înșeală. Nimic nu se putea forma în lipsa unor acumulări succesive datorită unei atracții (gravitații) la fel cum totul dispare, se transformă datorită acestei energii nepuizabile, nelimitate (singura energie real neconvențională). Nu ne referim la gravitația unei planete sau alta care este o gravitație convențională, ne referim la o gravitație neconvențională care își permite să atragă elemente (secvențe) neconvenționale "0" în **materie/energie** neconvențională și convențională, acolo unde materia și energia (gravitația) se confundă pînă la dispariția posibilității de convenționalizare. Ideea de a face structuri modulare nu este o noutate, dar ideea de a face structuri modulare din elemente neconvenționale este categoric nouă dar și imposibilă pînă la proba contrarie; (depinde pînă unde convenționalizăm noi neconvenționalul). Teoretic putem spune că este posibil în cazul nostru să modulăm atomii și moleculele și nu oamenii sau șoselele, dar nu eu sînt cel care poate face sau nu acest lucru fiecare știință are această sarcină în raport de direcția în care merge, poate nu merge dar ideea de modulare neconvențională (poate acum doar SF) va aduce mai devreme sau mai tîrziu soluții și modele noi neconvenționale. Dacă nu în construcții poate în transportarea în spațiu și timp a noastră sau pe alte planete. Poate și în matematică redefinim modulul în raport de elementele neconvenționale sau nedeterminate. Acumularea și divizarea sînt singurele operații neconvenționale (nelimitate, unice, etc.) respectiv adunarea și scăderea în convențional. Demonstrația este banală dacă ținem cont că un calculator face și desface orice fenomen, funcție, sistem, etc. doar prin adunare și scădere și doar cu 0 și 1. Savanții ca și artiștii sau orice geniu au căutat cifra perfectă, această cifră este 1 pentru convențional și 0 pentru neconvențional. Dacă vom ajunge la limita neconvențională când vom putea aduna și scădea doar cifre de 0 și să obținem aceleași rezultate convenționale, atunci vom fi noi Dumnezeu și nu vom avea limite. Ar rămîne totuși o singură diferență între convențional și neconvențional din acest punct de vedere, spațiul și timpul acestor acumulări sau divizări. Convenționalul le face în **spațiu/timp** limitat, în timp ce neconvenționalul în **spațiu/timp** nelimitat.

Concluzii

Trebuie să ținem cont că 0 și ∞ sînt valori constante, nelimitate, indiferent cît de mari sau de mici iar produsul lor nu poate fi decît o cifră constantă intermediară lor, regulă de altfel respectată și în convențional. Dacă însă în convențional produsul limitelor poate lua orice valoare între limitele respective, în neconvențional adică nelimitat nu poate lua orice valoare ci doar una singură, general valabilă, component

tuturor celorlalte valori. Nu putem concepe că 0 și ∞ sînt unice dar produsul lor dă valori multiple, absurd. Aceasă cifră a produsului nu poate să întrunească toate aceste condiții decît dacă cifra este 1. Un 1 care poate reprezenta și Universul în Sine dar și orice **entitate/univers** prin multiplii și submultipli lui. Pentru a studia diverse cazuri trebuie să stabilim elementele lui neutre, domeniile sale de definiție, limitele ca și unitățile sale de comparație. Orice **entitate/univers** are aceste elemente și orice parametru al ei de asemenea are aceste elemente. Matematicienii trebuie să găsească funcții pentru diverse **entități/univers**, să le adapteze la realitate să le asocieze un relativ apoi pe tot parcursul cunoașterii să completeze și să corecteze transformarea funcției pînă la perfecțiunea la care nu vom ajunge niciodată dar ghidează convențiile realității noastre relative; (funcția relativității $f(\lambda)$ este permanentă chiar și la valorile concrete și constante ale **entității/univers**). Orice funcție în cazul general, orice **entitate/univers** convențională pleacă de la elementele caracteristice, de aceea și funcției noastre trebuie să îi atribuim aceste elemente ca ea să devină o convenție (chiar dacă relativă) cu care să putem opera. La fel la orice **entitate/univers** (om, mașină, șosea, pom, energie, materie, etc.).

Bibliografie:

Florentin Smarandache & Tudor Păroiu, *Neutrosafia ca reflectarea a realității neconvenționale*, Ed. Sitech, Craiova, Romania, 130 p., 2012.

ADENDUM

Semnificații neconvenționale și convenționale

Pentru o bună sistematizare și înțelegere să definim cîteva convenții în noul sistem :

- ∞^* reprezintă infinitul limitat convențional
- ∞ îl redefinim ca infinitul nelimitat
- 0^* îl definim ca zero convențional limitat de mic
- 0 îl definim ca zero nelimitat de mic
- e_j este secvența convențională a entității în neconvențional
- u_j este secvența convențională a universului în neconvențional

- 1_0 este unitatea neconvențională **transformare spațiu timp** unde $1_0 = \sum_0^{\infty} 0$,

- $1^* = 1$ este unitatea convențională în neconvențional, $1^* = \sum_1^{\infty} 0^*$

- $E/U = \frac{\sum_1^{\infty} e_{j,1}^*}{\sum_0^{\infty} u_{j,2,0}}$ formula **entității/univers** generalizată și neconvențională, valabilă perfect și la entitățile de forma $\langle A \rangle$, $\langle \text{neut}A \rangle$, și $\langle \text{anti}A \rangle$ din neutrosofie.

Extension Communication for Solving the Ontological Contradiction between Communication and Information

Florentin Smarandache
University of New Mexico
200 College Road,
Gallup, NM 87301, U.S.A.

Ștefan Vlăduțescu
University of Craiova
Romania

The study lies in the interdisciplinary area between the information theory and extenics, as the science of solving the contradictions. This space addresses the central issue of the ontology information, the contradictory relationship between communication and information. The research core is the reality that the scientific research of communication-information relationship has reached a dead end. The bivalent relationship communication-information, information-communication has come to be contradictory, and the two concepts to block each other. With the Extenics as a science of solving the conflicting issues, "extenics procedures" will be used to solve the contradiction. In this respect, considering that the matter-elements are defined, their properties will be explored ("The key to solve contradictory problems, Wen Cai argues, the founder of Extenics (1999, p 1540), is the study of properties about matter-elements"). According to „The basic method of Extenics is called extension methodology” (...), and "the application of the extension methodology in every field is the extension engineering methods" (Weihai Li, Chunyan Yang, 2008, p 34).

With linguistic, systemic, and hermeneutical methods, grafted on "extension methodology" a) are "open up the things", b) is marked "divergent nature of matter-element", c) "extensibility of matter-element" takes place and c) "extension communication" allows a new inclusion perspective to open, a sequential ranging of things to emphasize at a higher level and the contradictory elements to be solved. "Extension" is, as postulated by Wen Cai (1999, p 1538) "opening up carried out".

After the critical examination of conflicting positions expressed by many experts in the field, the extenics and inclusive hypothesis is issued that information is a form of communication. The object of communication is the sending of a message. The message may consist of thoughts, ideas, opinions, feelings, beliefs, facts, information, intelligence or other significational elements. When the message content is primarily informational, communication will become information or intelligence.

The arguments of supporting the hypothesis are linguistic (the most important being that there is "communication of information" but not "information of communication"), systemic-procedural (in the communication system is developing an information system; the informing actant is a type of communicator, the information process is a communication process), practical arguments (the delimitation eliminates the efforts of disparate and inconsistent understanding of the two concepts), epistemological arguments (the possibility of inter-subjective thinking of reality is created), linguistic arguments (it is clarified and reinforced the over situated referent, that of the communication as a process), logical and realistic arguments (it is noted the situation that allows to think coherently in a system of concepts - derivative series or integrative groups) and arguments from historical experience (the concept of communication has temporal priority, it appears 13 times with Julius Caesar). The main arguments are summarized in four axioms: three are based on the pertinent observations of Tom D. Wilson-Marcus Solomon, Magoroh Maruyama and Richard Varey, and the fourth is a relevant application of Florentin Smarandache's neutrosophic theory on communication.

Keywords: extension communication, information, extenics, ontology, neutrosophic communication, message

I. The information thesis as a form of communication

The question of the relationship between communication and information as fields of existence is the fingerprint axis of communication and information ontology. The ontological format allows two formulas: the existence in the act and the virtual existence. The ontological component of the concepts integrates a presence or a potency and an existential fact or at a potential of existence.

In addition to the categorial-ontological element, in the nuclear ratio of communication-information concepts it shows comparative specificities and regarding attributes and characteristics, on three components, epistemological, methodological and hermeneutical.

In a science which would have firmly taken a strong subject, a methodology and a specific set of concepts, this ontological founding decision would be taken in an axiom. It is known that, in principle, axioms solve within the limits of that type of argument called evidence (clear and distinct situation), the relations between the systemic, structural, basic concepts. Specifically, in Extenics, scientists with an advanced vision, substantiated by professor Wen Cai, axioms govern the relationship between two matter-elements with divergent profiles. For the communication and information issues that have occurred relatively recently (about three quarters of a century) in subjects of study or areas of scientific concern not a scientific authority to settle the issue

was found. The weaknesses of these sciences of soft type are visible even today when after non accredited proposals of science ("comunicology" - comunicology Joseph De Vito, "communicatics," - "comunicatiqué" of Metayer G., informatology - Klaus Otten and Anthony Debon) it was resorted to the remaining in the ambiguity of validating the subject "The sciences of communication and information" or "The sciences of information and communication", enjoying the support of some courses, books, studies and dictionaries.

This generic vision of unity and cohesion wrongs both the communication and information. In practice, the apparent unjust overall, integrative, altogether treatment has not an entirely and covering confirmation. In almost all humanist universities of the world the faculties and the communication courses are prevailing, including those of Romania and China. Professor Nicolae Drăgulănescu ascertained in what Romania is concerned, that in 20 colleges communication (with various denominations) is taught and in only two the informing-information is taught.

The main perspectives from which the contradictory relationship of communication-information was approached are the ontological, the epistemological and the systemic. In most cases, opinions were incidental. When it was about the dedicated studies, the most common comparative approach was not programmatically made on one or more criteria and neither directly and applied. Jorge Reina Schement, R. Brent Ruben, Harmut B. Mokri and Magoroh Maruyama's contributions remain fundamental.

In his study "Communication and Information" (19 March 9, pp. 3-31), J. R. Schement starts from the observation that "in the rhetoric of the Information Age, the communication and information converge in synonymous meanings." On the other hand, he retains that there are specialists who declare in favor of stating a firming distinction of their meanings. To clarify exactly the relationship between the two phenomena, i.e. concepts, he examines the definitions of information and communication that have marked the evolution of the "information studies" and the "communication studies". For informing (information) three fundamental themes result: information-as-thing (M. K. Buckland), information-as-process (N.J. Belkin, R.M. Hays, Machlup & Mansfield, etc.), Information-as-product-of - manipulation (C.J. Fox, R.M. Hayes). It is also noted that these three subjects involve the assessing of their issuers, a "connection to the phenomenon of communication". In parallel, from examining the definitions of communication it is revealed that the specialists "implicitly or explicitly introduce the notion of information in defining communication". There are also three the central themes of defining communication: communication-as-transmission (W. Weaver, E. Emery, C. Cherry, B. Berelson, G. Steiner), communication-as-sharing-process (RS Gover, W. Schramm), communication-as-interaction (G. Gerbner, L. Thayer). Comparing the six thematic nodes, Schement emphasizes that the link between

information and communication is "highly complex" and dynamic "information and communication is ever present and connected" (Schement JR, 1993, p 17). In addition, in order that "information exist, the potential for communication must be present".

The result at the ontological level of these findings is that the existence of information is (strictly) conditioned by the presence of communication. That is for the information to occur communication must be present. Communication will precede and always condition the existence of information. And more detailed: communication is part of the information ontology. Ontologically, information occurs in communication also as potency of communication. J. R. Schement is focused on finding a way to census a coherent image leading to a theory of communication and information ("Toward a Theory of Communication and Information" - Schement JR, 1993, p 6). Therefore, he avoids to conclusively asserting the temporal and linguistic priority, the ontological precedence and the amplitude of communication in relation to information. The study concludes that 1. "Information and communication are social structures" ("two words are used as interchangeable, even as synonyms" – it is argued) (Schement JR, 1993, p 17), 2. "The study of information and communication share concepts in common" (in both of them communication, information, "symbol, cognition, content, structure, process, interaction, technology and system are to be found" - Schement JR, 1993, p 18), 3. "Information and communication form dual aspects of a broader phenomenon" (Schement J.R., 1993, p. 18). In other words, we understand that: a) linguistically ("words", "terms", "notions", "concepts", "idea of") communication and information are synonyms; b) as area of study the two resort the same conceptual arsenal. Situation produced by these two elements of the conclusion allows, in our opinion, a hierarchy between communication and information. If it is true that ontologically and temporally the communication precedes information, if this latter phenomenon is an extension smaller than the first, if eventual sciences having communication as object, respectively information, benefit from the one and the same conceptual vocabulary, then the information can be a form of communication. Despite this line followed coherently by the linguistic, categorical-ontological, conceptual and definitional epistemological arguments brought in the reasoning, the third part of the conclusion postulates the existence of a unique phenomenon which would include communication and information (3. "Information and communication form two aspects of the same phenomenon "- Schement JR, 1993, p 18). This phenomenon is not named. The conclusive line followed by the arguments and the previous conclusive elements enabled us to articulate information as one of the forms of communication. Confirmatively, the fact that JR Schement does not name a phenomenon situated over communication and information, gives us the possibility of attracting the argument in order to strengthen our thesis that information is a form of communication. That is because a category of

phenomena encompassing communication and information cannot be found. J. R. Schement tends towards a leveling perspective and of convergence in the communication and information ontology. Instead, M. Norton supports an emphasized differentiation between communication and information. He belongs to those who see communication as one of the processes and one of the methods "for making information available". The two phenomena "are intricately connected and have some aspects that seem similar, but they are not the same" (M. Norton, 2000, p 48 and 39). Harmut B. Mokros and Brent R. Ruben (1991) lay the foundation of a systemic vision and leveling understanding of the communication-information relationship. Taking into account the context of reporting as a core element of the internal structure of communication and information systems, they mark the information as a criterion for the radiography of relationship. The systemic-theoretical non-linear method of research founded in 1983 by B. R. Ruben is applied to the subject represented by the phenomena of communication and information. Research lays in the "Information Age" and creates an informational reporting image. The main merit of the investigation comes from the relevance given to the non-subordination between communication and information in terms of a unipolar communication that relates to leveling information. Interesting is the approach of information in three constituent aspects: "informatione" (potential information - that which exists in a particular context, but never received a significance in the system), "information" (active information in the system) and "information" (information created socially and culturally in the system). The leveling information is related to a unified communication. On each level of information there is communication. Information and communication is co-present: communication is inherent to information. Information has inherent properties of communication. Research brings a systemic-contextual elucidation to the relationship between communication and information and only subsidiarily a firm ontological positioning. In any case: in information communication never misses.

In the most important studies of the professor Stan Petrescu: "Information, the fourth weapon" (1999) and "About intelligence. Espionage-Counterespionage"(2007), information is understood as "a type of communication" (Petrescu S., 1999, p 143) and situated in the broader context of "knowledge on the internal and international information environment "(S. Petrescu, 2007, p 32).

II. The subject of communication: the message. The subject of informing: the information. The information thesis as species of message

In order to finish our basic thesis that of the information as a form of communication, new arguments may be revealed which corroborate with those previously mentioned. As phenomena, processes, the communication and

information occur in a unique communication system. In communication, information has acquired a specialized profile. In the information field, the intelligence, in his turn, strengthened a specific, detectable, identifiable and discriminative profile. It is therefore acceptable under the pressure of practical argument that one may speak of a general communication system which in relation to the message sent and configured in the communication process could be imagined as information system or intelligence system. Under the influence of the systemic assumption that a (unitary) communicator transmits or customize transactionally with another (receiving) communicator a message, one may understand the communicational system as the interactional unit of the factors that exerts and fulfill the function of communicating a message.

In his books "Messages: building interpersonal communication skills" (attained in 1993 its fourth edition and in 2010 its twelfth) and "Human Communication" (2000), Joseph De Vito (the renowned specialist who has proposed the name "Communicology" for the sciences of communication - 1978), develops a concept of a simple and productive message. The message is, as content, what is communicated. As a systemic factor, it is emerging as what is communicated. To remember in this context is that the German Otto Kade insisted that what it is communicated to receive the title of "release". According to Joseph De Vito, through communication meanings are transmitted. "The communicated message" is only a part of the meanings (De Vito J., 1993, p 116). Among the shared meanings feelings and perceptions are found (De Vito J., 1993, p. 298). Likewise, information can be communicated (De Vito J., 1990, p 42), (De Vito J., 2000, p 347).

In a "message theory" called "Angelitică" (Angelitics), Rafael Capurro argues that the message and information are concepts that designate similar but not identical phenomena. In Greek "Angela" meant message; from here, "Angelitica" or theory of the message (Angelitica is different from Angeologia dealing, in the field of religion and theology, with the study of angels) (<http://www.capurro.de/angelitics.html>). R. Capurro set four criteria for assessing the relationship between message and information. The similarity of the two extends over three of them. The message, as well as the information, is characterized as follows: „is supposed to bring something new and/or relevant to the receiver; can be coded and transmitted through different media or messengers; is an utterance that gives rise to the receiver's selection through a release mechanism of interpretation". "The difference between these two is the next: „a message is sender-dependent, i.e. it is based on a heteronomic or asymmetric structure. This is not the case of information: we receive a message but we ask for information" (http://www.capurro.de/angeletics_zkm.html). To request information is to send a message of requesting information. Therefore, the message is similar to the information in this respect too. In our opinion, the difference between them is from genus to species: information is a species of message. The message depends on the transmitter and the information, as well.

Information is still a specification of the message, is an informative message. C. Shannon asserts that the message is the defining subject of the communication. He is the stake of the communication because „the fundamental problem of communication is that of reproducing at one point either exactly or approximately a message selected at another point” (1949, p. 31).

The communication process is in fact the "communication" of a complex and multilayered message. "Thoughts, interests, talents, experiences"(Duck S., Mc Mahan D.T., 2011, p 222), "information, ideas, beliefs, feelings "(Wood J.T., 2009, p 19 and p 260) can be found in a message. G. A. Miller, T. M. Newcomb and Brent R. Ruben consider that the subject of communication is information: "Communication - Miller shows – means that information is passed from one place to another” (Miller G. A., 1951, p. 6). In his turn, T. M. Newcomb asserts: „very communication act is viewed as a transmission of information” (Newcomb T. M., 1966, p. 66) and Brent R. Ruben argues: „Human communication is the process through which individuals in relationships, groups, organizations and societies create, transmit and use information to relate to the environment and one another” (Ruben B. R., 1992, p. 18).

Professor Nicolae Drăgulănescu, member of the American Society of Information Science and Technology, is the most important of Romanian specialists in the Science of information. According to him, "communicating information" is the third of the four processes that form the "informational cycle", along with generating the information, processing/storing the information and the use of information. The process of communication, N. Dragulanescu argues, is one of the processes whose object is the information (<http://ndragulanescu.ro/publicatii/CP54.pdf>, p 8). The same line is followed by Gabriel Zamfir too; he sees the information as "what is communicated in one or other of the available languages" (Zamfir G., 1998, p. 7), as well as teacher Sultana Craia: communication is a "process of transmitting a piece of information, a message" (Crai S., 2008, p 53). In general, it is accepted that information means transmitting/receiving information. However, when speaking of transmitting information, the process is considered not to be information but communication. Therefore, it is created the appearance that the information is the product and communication would only be the transmitting process. Teodoru Ștefan, Ion Ivan și Cristian Popa assert: "Communication is the process of transmitting information, so the ratio of the two categories is from the basic product to its transmission" (Stephen T., Ivan I., Popa C., 2008, p 22). The professors Vasile Tran and Irina Stănciugelu see communication as an "exchange of information with symbolic content" (V. Tran, Stănciugelu I., 2003, p 109). The communication is an over-ranged concept and an ontological category more extended than informing or information. On the other hand, information is generated even in the global communication process. From this point of view, information (whose subject-message is information) is a regional,

sectorial communication. Information is that communication whose message consists of new, relevant, pertinent and useful significances, i.e. of information. This position is shared by Doru Enache too (2010, p 26).

The position set by Norbert Wiener, consolidated by L. Brillouin and endorsed by many others makes from the information the only content of the message. N. Wiener argues that the message "contains information" (Wiener N., 1965, p 16), L. Brillouin talks about "information contained in the message" (L. Brillouin, 2004, p 94 and p 28).

Through communication "information, concepts, emotions, beliefs are conveyed" and communication "means (and subsumes) information" (Rotaru N., 2007, p.10). Well-known teachers Marius Petrescu and Neculae Năbârjoiu consider that the distinction between communication and information must be achieved depending on the message. A communication with an informational message becomes information. As a form of communication, information is characterized by an informative message and a "message is informative as long as it contains something unknown yet" (M. Petrescu, Năbârjoiu N., 2006, p 25). One of the possible significant elements that could form the message content is thus the information as well. Other components could be thoughts, ideas, beliefs, knowledge, feelings, emotions, experiences, news facts. Communication is "communicating" a message regardless of its significant content.

III. Four axioms of communication-information ontology

3.1. The message axiom. We call the ontological segregation axiom on the subject or the Tom D. Wilson-Solomon Marcus' axiom, the thesis that not any communication is information, but any information is communication. Whenever the message contains information, the communicational process will acquire an informational profile. Moreover, the communicational system becomes informational system. Derivatively, the communicator becomes the "informer" and the communicational relationship turns into informational relationship. The interactional basis of society, even in the Information Age, is the communicational interaction. Most social interactions are non-informational. In this respect, T. D. Wilson has noted: „We frequently receive communications of facts, data, news, or whatever which leave us more confused than ever. Under formal definition these communications contain no information” (Wilson T. D., 1987, p. 410). Academician Solomon Marcus takes into account the undeniable existence of a communication "without a transfer of information" (Marcus S., 2011, vol. 1. P. 220). For communications that do not contain information we do not have a separate and specific term. Communications containing information or just information are called informing.

Communication involves a kind of information, but as Jean Baudrillard

stated (Apud Dancu VS, 1999, p 39), "it is not necessarily based on information". More specifically, any communication contains cognition that can be knowledge, data or information. Therefore, in communication, information may be missing, may be adjacent, incidental or collateral. Communication can be informational in nature or its destination. That communication which by its nature and organization is communication of information is called informing.

The main process ran in Information System is informing. The function of such a system is to inform. The actants can be informants, producers-consumers of information, transmitters of information, etc. The information action takes identity by the cover enabled onto-categorial by the verb "to inform". In his turn, Petros A. Gelepithis considers the two concepts, communication and information to be crucial for "the study of information system" (Gelepithis PA, 1999, p 69).

Confirming the information axiom as post reductionist message, as reduced object of communication, Soren Brier substantiates: „communication system actually does not exchange information” (Brier S., 1999, p. 96). Sometimes, within the communication system information is no longer exchanged. However, communication remains; communication system preserves its validity, which indicates and, subsequently, proves that there can be communication that does not involve information.

Then:

a) when in the Information System functional principles such as "need to know"/"need to share" are introduced,

b) when running processes for collecting, analyzing and disseminating information,

c) when the beneficiaries are deciders, "decision maker", "ministry", "government", "policymakers" and

d) when the caginess item occurs,

this Information System will become Intelligence System (see Gill P., MarrinS., Phytian M., 2009, p. 16, p. 17, p. 112, p. 217), (Sims J.E., Gerber B., 2005, p. 46, p. 234; Gill P., Phytian S., 2006, p. 9, p. 236, p. 88; Johnson L.K. (ed.) 2010, p. 5, p. 6, p. 61, p. 392, p. 279, Maior G.-C. (ed.), 2010). "Secrecy, Peter Gill establishes, is the Key to Understanding the essence of intelligence" (Gill P., S. Marrin, Phyti of n M., 2009, p 18), and professor George Cristian Maior emphasizes: "in intelligence, collecting and processing information from secret sources remain essential" Major G.-C., 2010, p 11).

Sherman Kent, W. Laqueur, M.M. Lowenthal, G.-C. Major etc. start from a complex and multilayered concept of intelligence, understood as meaning

knowledge, activity, organization, product, process and information. Subsequently, the question of ontology, epistemology, hermeneutics and methodology of intelligence occurs. Like Peter Gill, G.-C. Major does pioneering work to separate the ontological approach of intelligence from the epistemological one and to analyze the "epistemological foundation of intelligence" (Major G.-C., 2010, p 33 and p 43).

The intelligence must be also considered in terms of ontological axiom of the object. In this regard, noticeable is that one of its meanings, perhaps the critical one, places it in some way in the information area. In our opinion, the information that has critical significance for accredited operators of the state, economic, financial and political power, and holds or acquires confidential, secret feature is or becomes intelligence. Information from intelligence systems can be by itself intelligence or end up being intelligence after some specialized processing. "Intelligence is not just information that merely exists" (Marina M., Ivan I., 2010, p 108), Mariana Marinică and Ion Ivan assert, it is acquired after a "conscious act of creation, collection, analysis, interpretation and modeling information" (Marina M., Ivan I., 2010, p 105).

3.2. Teleological axiom. In addition to the axiom of segregating communication, of informing in relation to the object (message), it may be stated as an axiom a Magoroh Maruyama's contribution to the demythologization of information. In the article "Information and Communication in Poly Epistemological System" in "The Myths of Information", he states: „The transmission of information is not the purpose of communication. In Danish culture, for example, the purpose of communication is frequently to perpetuate the familiar, rather than to introduce new information” (1980, p. 29).

The ontological axiom of segregation in relation to the purpose determines information as that type of communication with low emergence in which the purpose of the interaction is transmitting information.

3.3. Linguistic axiom. A third axiom of communication-information ontological segregation can be drawn in relation to the linguistic argument of the acceptable grammatical context. Richard Varey considers that understanding "the difference between communication and information is the central factor" and finds in the linguistic context the criterion to validate the difference: „we speak of giving information **to** while communicate **with** other” (1997, p. 220). The transmission of information takes place "to" or to someone, and communication takes place "with". Along with this variant of grammatical context it might also emerge the situation of acceptability of some statements in relation to the object of the communication process, respectively the object of the information process.

The statement "to communicate a message, information" is acceptable. Instead, the statement "to inform communication" is not. The phrase "communication of messages-information" is valid, but the phrase "informing of

communication", is not. Therefore, language bears knowledge and "lead us" (Martin Heidegger states) to note that, linguistically, communication is more ontological extensive and that information ontology is subsumed to it.

The ontical and ontological nature of language allows it to express the existence and to achieve a functional-grammatical specification. Language allows only grammatical existences. As message, the information can be "communicated" or "communicable". There is also the case in which a piece of information can not be "communicated" or "communicable". Related, communication can not be "informed". The semantic field of communication is therefore larger, richer and more versatile. Communication allows the "incommunicable".

3.4. The neutrosophic communication axiom. Understanding the frame set by the three axioms, we find that some communicational elements are heterogeneous and neutral in relation to the criterion of informativity. In a speech some elements can be suppressed without the message suffering informational alterations. This means that some message-discursive meanings are redundant; others are not essential in relation to the orexis-the practical course or of practical touch in the order of reasoning. Redundancies and non-nuclear significational components can be elided and informational and the message remains informationally unchanged. This proves the existence of cores with neutral, neutrosophic meanings. (In the epistemological foundations of the concept of neutrosophy we refer to Florentin Smarandache's work, *A Unifying Field in Logics, Neutrosophic Logic, Neutrosophy, Neutrosophic Set, Neutrosophic Probability and Statistics*, 1998).

On the operation of this phenomenon are based the procedures of textual contraction, of grouping, of serial registration, of associating, summarizing, synthesizing, integrating.

We propose to understand by neutrosophic communication that type of communication in which the message consists of and it is based on neutrosophic significational elements: non-informational, redundant, elidable, contradictory, incomplete, vague, imprecise, contemplative, non-practical, of relational cultivation. Informational communication is that type of communication whose purpose is sharing an informational message. The issuer's fundamental approach is, in informational communication, to inform. To inform is to transmit information or, specifically, in the professor's Ilie Rad words: "to inform, that is just send information" (Moldovan L., 2011, p 70). In general, any communication contains some or certain neutrosophic elements, suppressible, redundant, elidable, non-nuclear elements. But when neutrosophic elements are prevailing communication is no longer informational, but neutrosophic. Therefore, the neutrosophic axiom allows us to distinguish two types of communication: neutrosophic communication and informational communication. In most of the time our communication is neutrosophic. The

neutrosophic communication is the rule. The informational communication is the exception. In the ocean of the neutrosophic communication, diamantine islands of informational communication are distinguished.

BIBLIOGRAPHY

1. Brier S., *What is a Possible Ontological and Epistemological Framework for a true Universal Information Science*, în Hofkirshner W. (ed.), *The Quest for a unified Theory of Information*, Amsterdam, Gordon and Breach Publishers, 1999.
2. Brillouin L., *Science and Information Theory*, 2nd edition, New York, Dober Publications Inc., 2004.
3. Cai Wen, *Extension Theory and its Application*, Chinese Science Bulletin, vol. 44, nr. 17, pp. 1538-1548, 1999.
4. Craia Sultana, *Dicționar de comunicare, mass-media și știința comunicării*, București, Editura Meronia, 2008.
5. Dâncu V. S., *Comunicarea simbolică*, Cluj-Napoca, Editura Dacia, 1999.
6. DeVito, J. A., *Communicology*, New-York, Harper and Row, 1982.
7. DeVito J., *Messages*, Harper Collins College Publishers, 1993.
8. DeVito J., *Human Communication*, Addison Wesley Longman Inc., 2000.
9. Dobreanu Cristinel, *Preventing surprise at the strategic level*, Buletinul Universității Naționale de Apărare „Carol I”, anul XX, nr. 1, pp. 225-233, 2010.
10. Duke S., Mc Mahan D.T., *The Basics of Communication*, London, Sage Publications Inc., 2011.
11. Enache Doru, *Informația, de la primul cal troian la cel de-al doilea cal troian*, Parașutiștii, anul XIV, nr. 27(36), pp. 25-28, 2010.
12. Gelepithis P.A., *A rudimentary theory of information* în Hofkirshner W. (ed.), *The Quest for a unified Theory of Information*, Amsterdam, Gordon and Breach Publishers, 1999.
13. Gill P., Phytian S., *Intelligence in an insecure world*, Cambridge, Polity Press, 2006.
14. Gill P., Marrin S., Phytian S., *Intelligence Theory: Key questions and debates*, Routledge, New York, 2009.
15. Li Weihua, Yang Chunyan, *Extension Information-Knowledge-Strategy System for Semantic Interoperability*, Journal of Computers, vol. 3, no. 8, pp. 32-39, 2008.
16. Marinică M., Ivan I., *Intelligence – de la teorie către știință*, Revista Română de Studii de Intelligence, nr. 3, pp. 103-114, 2010.
17. Johnson L.K. (ed.), *The Oxford of Nnational Security Intelligence*, Oxford University Press, 2010.
18. Maior George Cristian, *Un război al minții. Intelligence, servicii de informații și cunoaștere strategică în secolul XXI*, București, Editura

- RAO, 2010.
19. Marinescu Valentina, *Introducere în teoria comunicării*, București, Editura C. H. Beck, 2011.
 20. Marcus Solomon, *Întâlniri cu /meetings with Solomon Marcus*, București, Editura Spandugino, 2011, 2 volume.
 21. Maruyama M., *Information and Communication in Poly-Epistemological Systems*, în Woodward K. (ed.), *The Myths of Information*, Routledge and Kegan Paul Ltd., 1980.
 22. Métayer, G., *La Communicatiquie*, Paris, Les éditions d'organisation, 1972.
 23. Miller G.A., *Language and communication*, New York, Mc-Graw-Hill, 1951.
 24. Mokros H.B. și Ruben B.D., *Understanding the Communication-Information Relationship: Levels of Information and Contexts of Availabilities*, Science Communication, June 1991, vol. 12, no. 4, pp. 373-388.
 25. Moldovan L., *Indicii jurnalistice. Interviu cu prof. univ. dr. Ilie Rad în Vatra veche*, Serie nouă, Anul III, nr. 1(25), ianuarie 2011 (ISSN2066-0962), pp. 67-71.
 26. Newcomb TM, *An Approach to the study of communicative acts*, în Smith A.G. (ed), *Communication and culture*, New York, Holt, Rinehart and Winston, 1966.
 27. Norton M., *Introductory concepts of Information Science*, Information Today, Inc., 2000.
 28. Păvăloiu Catherine, *Elemente de deontologie a evaluării în contextul creșterii calității actului educațional*, Forțele terestre, nr. 1/2010.
 29. Petrescu Marius, *Năbârjoiu Neculae Managementul informațiilor*, vol. I, Târgoviște, Editura Bibliotheca, 2006.
 30. Petrescu Stan, *Despre intelligence. Spionaj-Contraspionaj*, București, Editura Militară, 2007.
 31. Petrescu Stan, *Informațiile, a patra armă*, București, Editura Militară, 1999.
 32. Popa C., Ștefan Teodoru, Ivan Ion, *Măsurile organizatorice și structuri funcționale privind accesul la informații*, București, Editura ANI, 2008.
 33. Popescu C. F., *Manual de jurnalism*, București, Editura Tritonic, 2004, 2 volume.
 34. Rotaru Nicolae, *PSI-Comunicare*, București, Editura A.N.I., 2007.
 35. Ruben B.D., *The Communication-information relationship in System-theoretic perspective*, Journal of the American Society for Information Science, volume 43, issue 1, pp. 15-27, January 1992.
 36. Ruben B.D., *Communication and human behavior*, New York, Prentice Hall, 1992.
 37. Schement J.R., *Communication and information* în Schement J.R.,

- Ruben B.D., *Information and Behavior*, volume 4, Between Communication and Information, Transaction Publishers, New Brunswick, New Jersey, 1993.
38. Shannon C., Weaver W., *The mathematical theory of communication*, Urbana, University of Illinois Press, 1949.
39. Sims J.E., Gerber B., *Transforming US Intelligence*, Washington D.C., Georgetown University Press, 2005.
40. Smarandache F., *A Unifying Field in Logics, Neutrosophic Logic, Neutrosophy, Neutrosophic Set, Neutrosophic Probability and Statistics*, American Research Press, Rehoboth, 1998.
41. Smarandache F., *Toward Dialectic Matter Element of Extenics Model*, sursă Internet, 2005.
42. Tran V., Stănciugelu I., *Teoria comunicării*, București, comunicare.ro, 2003.
43. Vlăduțescu Ștefan, *Informația de la teorie către știință*, București, Editura Didactică și Pedagogică, 2002 (in romanian), *Information, from theory to science*.
44. Vlăduțescu Ștefan, *Comunicarea jurnalistică negativă*, București, Editura Academiei Române, 2006 (in romanian), *Negative Journalistical Communication*.
45. Wiener N., *Cybernetics*, 3th ed., Mit Press, 1965.
46. Wilson T.D., *Trends and issues in information science*, în Boyd-Barrett O., Braham P., *Media, Knowledge and Power*, London, Croom Helm, 1987.
47. Wood J.T., *Communication in Our Lives*, Wadsworth/Cengage learning, 2009.
48. Zamfir G., *Comunicarea și informația în sistemele de instruire asistată de calculator din domeniul economic*, Informatica Economică, nr. 7/1998, p. 7.

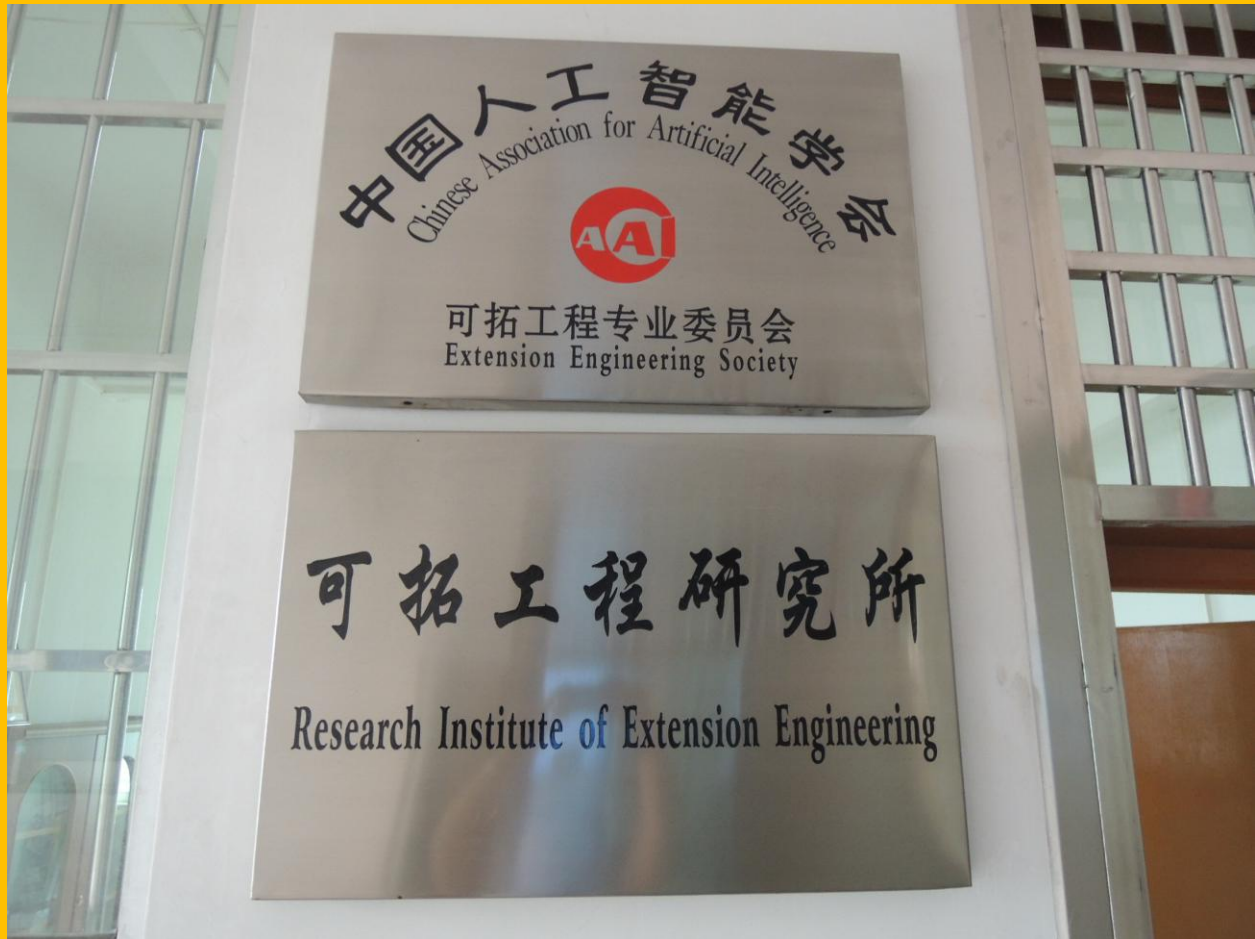

Prof. Florentin Smarandache, during his research period in the Summer of 2012 at the Research Institute of Extenics and Innovation Methods, from Guangdong University of Technology, in Guangzhou, China, has introduced the *Linear and Non-Linear Attraction Point Principle* and the *Network of Attraction Curves*, he has generalized the *1D Extension Distance* and the *1D Dependent Function* to 2D, 3D, and in general to *n-D Spaces*, and he generalized Qiao-Xing Li's and Xing-Sen Li's definitions of the *Location Value of a Point* and the *Dependent Function of a Point on a Single Finite Interval* from one dimension (1D) to 2D, 3D, and in general *n-D spaces*.

He used the Extenics, together with Victor Vlădăreanu, Mihai Liviu Smarandache, Tudor Păroiu, and Ștefan Vlăduțescu, in 2D and 3D spaces in technology, philosophy, and information theory.

Extenics is the science of solving contradictory problems in many fields set up by Prof. Cai Wen in 1983.



9 781599 732039