

Design and Automation of Security Management System for Industries Based On M2M Technology

Swathi Bhupatiraju^[1] T J V Subrahmanyeswara Rao^[2] M.Tech

^[1] M.Tech. Student, Department of ECE, Swathi.bhupatiraj@gmail.com

^[2] Associate Professor, Department of ECE, tjvsrao@yahoo.in

Sasi Institute of Technology and Engineering, Tadepalligudem

Abstract:

Security Management at the industries is very important requirement, especially at night times. Security people always needed to monitor the industries sites. Somebody should present always in onsite to protect industry from thievery. In this paper an idea of protecting industry is by automating industry security system is presented. The idea developed using ARM processor which is an industry leading embedded processor and a GUI is developed which is very useful for remote monitoring and collecting information.

To attain reliability the improvement of the security level with the help of GSM based wireless technology which consists of transmitter (GSM modem) at the site location and receiver is the GSM mobile. Information transmitted by the GSM modem at the plant location will be sent to the respective person's mobile as a text message.

Keywords: M2M Technology, ARM7, wireless security applications

1. INTRODUCTION

Now a day's every system is automated in order to face new challenges. In the present days automated systems have less manual operations in terms of flexibility, reliability and accurate. Due to this increase in demand every field prefers to automate control systems. This scenario implies to industries where so many parameters need to look after. Automation based on advanced electronics technologies giving fruitful results in every aspect. Combination of technologies in various areas and embedding into one system can be very useful to automate a particular scenario. In this case we have designed a system which can monitor the onsite and also analyze some important on field paramagnets.

This system assists security people to great extent to monitor and inspect the entire site. This is realized by making use of Zigbee technology for communications. It is guided by IEEE 802.15.4 Personal Area Network standard. It is primarily designed for the wide ranging controlling applications and to replace the existing non-standard technologies. It currently operates in 868MHz band at a data rate of 20Kbps in Europe, 914MHz band at 40kbps in USA, and the 2.4GHz ISM bands Worldwide at a maximum data-rate of 250kbps.

2. M2M TECHNOLOGY

M2M is an emerging technology that allows both wireless and wired systems to communicate with other devices of the same ability. This technology uses a device to capture a parameter like temperature, inventory level etc. which is relayed through a network wireless or wired. This is again translates the captured event into meaningful information such communication was originally proficient by having a remote network of machines relay information back to a central hub for analysis.

Recent M2M communication has expanded beyond a one-to-one connection and changed into a multi level communication over a network. The growth of wireless networks across the world has made it far easier for M2M communication to take place. SMS has become an increasingly important transmission mechanism for M2M communication because of its uniqueness and low-priced availability.

This article designs a monitoring system based on Zigbee technology to build wireless sensor network. The sensor nodes in the underground section will send the collected data to an embedded network controller based on ARM kernel. Then the controller receives the data and sends them to the ground PC by the use of Zigbee protocol. With the concept of M2M (machine to machine, machine to mobile, mobile to machine), the ground PC saves the parameter values and the microcontroller transmits the monitoring results to the mobile phones through GPRS, and the abnormal situations can be dealt with in time. In addition, the mobile inquiring service can also be supported.

3. CORE PROCESSOR & HW INTERFACING

ARM stands for Advanced RISC Machines. It is a 32 bit processor core, used for high end application. It is widely used in Advanced Robotic Applications. The ARM architecture has been designed to allow very small, yet high-performance implementations. The architectural simplicity of ARM processors leads to very small implementations, and small implementations allow devices with very low power consumption. The ARM is a Reduced Instruction Set Computer (RISC), as it incorporates all typical RISC features. Because of its low power consumption and high performance ARM is the platform which exactly suits for industry level application development.

A GUI (Graphical User Interface) developed which communicates to ARM serially and resides on PC. This GUI is very useful to monitor the remote sites and take the record of different industry parameters over a time frame.

GSM (Global System for Mobile communication) is a digital mobile telephone system that is widely used in many parts of the world. GSM uses a variation of Time Division Multiple Access (TDMA) and is the most widely used of the three digital wireless telephone technologies (TDMA, GSM, and CDMA). GSM digitizes and compresses data, then sends it down a channel with two other streams of user data, each in its own time slot. GSM operates in the 900MHz, 1800MHz, or 1900 MHz frequency bands. A GSM network is composed of several functional entities, whose functions and interfaces are specified. Figure 1 shows the layout of a generic GSM network. The GSM network can be divided into three broad parts. Subscriber carries the Mobile Station. The Base Station Subsystem controls the radio link with the Mobile Station. The Network Subsystem, the main part of which is the Mobile services Switching Center (MSC), performs the switching of calls between the mobile users, and between mobile and fixed network users.

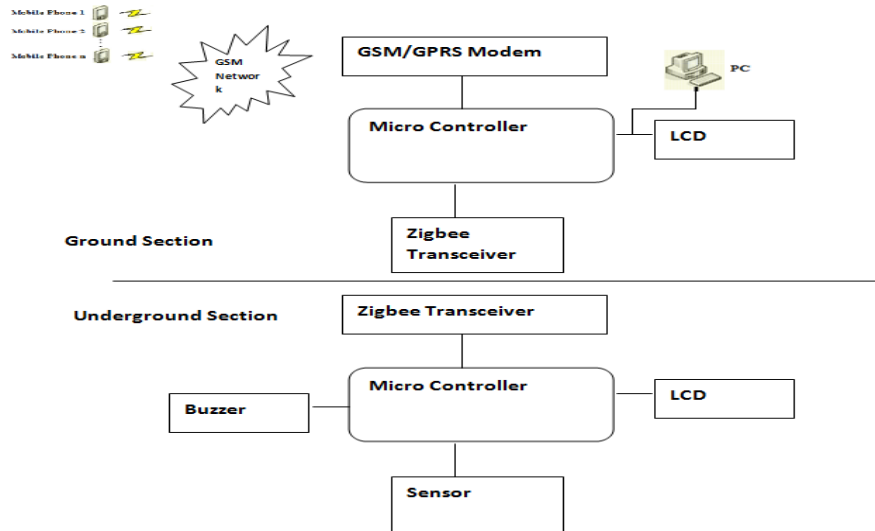

Figure (i) Conceptual diagram

The block diagram of the design is shown in the figure 1 below. Here ARM core is connected to the GSM modem and Zigbee device. LCD interfacing is also provided for continues monitoring. GSM interfaced to ARM processor gets data from the user mobiles continuously and displays the updated information on the connected LCD screen. The ZIGBEE specification operates in the 2.4GHz (ISM) radio band - the same band as 802.11b standard, Bluetooth, microwaves and some other devices. It is capable of connecting 255 devices per network. The specification supports data transmission rates of up to 250 Kbps at a range of up to 30 meters. ZIGBEE's technology is slower than 802.11b (11 Mbps) and Bluetooth (1 Mbps) but it consumes significantly less power.

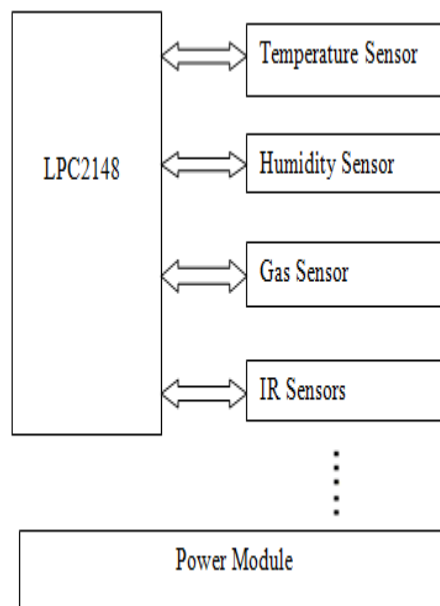

Fig (ii) Interfacing of sensors with ARM7 Hardware diagram

Temperature Sensor (Thermistor), Gas Sensor, IR Sensors are used here to get different parameters like temperature, gas leakage etc. temperature sensors the word thermistor is an acronym for thermal resistor, i.e., a temperature sensitive resistor. It is used to detect very small changes in temperature. The variation in temperature is reflected through appreciable variation of the resistance of the device. The negative-temperature coefficient means that the resistance increases with the increase in temperature. gas sensors They are used in GAS leakage detecting equipments in family and industry, are suitable for detecting of LPG, i-butane, propane, methane, alcohol, Hydrogen, smoke shows alterable situation of RL signal output measured by using Fig. 2 circuit output signal when the sensor is shifted from clean air to Carbon monoxide (CO), output signal measurement is made within one or two complete heating period (2.5 minute from high voltage to low voltage).

4. SOFTWARE SECTION

The complete hardware design and automation is divided in to two phases. The first portion is underground section and rest of the development is of ground section. Figure (i) gives the complete structure of this design. The designed systems are placed in different parts of the mine and connected by means of Zigbee.

In underground section the sensors will sense the environment conditions such as temperature, humidity, gas etc., and this information is send to ADC of the micro controller, the number of members inside the coalmine is also obtained by means of IR sensor.

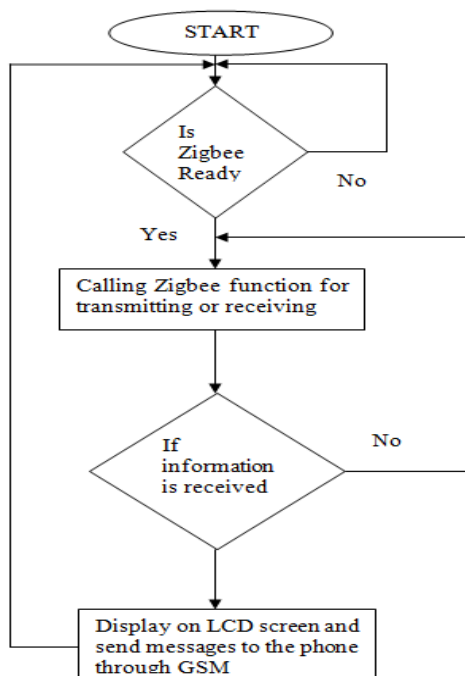
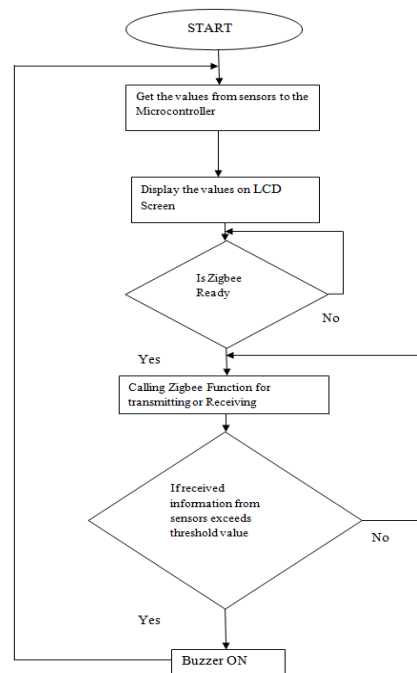

Figure (iii) Functional flow diagram



Figure(iv) Algorithm of System functionality

The functional diagram above in figure (ii) represents the operational behavior of the system designed. This operation entirely depends on the wireless communications. As described above Zigbee technology is best used to get wide range of benefits. The quick start of the system is from the Zigbee device. If Zigbee is ready then the Zigbee function starts working which sends or receives the information. Again second point of check is there to confirm the information received or not. If information through Zigbee is received then the message displayed on the LCD screen. The internal flow of functionality is well defined by software. The software flowchart is as shown in the figure (iv).

The sensors information is taken as main input for estimating the site conditions. The real view of sensors and Zigbee module is shown in the figure (v) below. The model code snippet for LCD interfacing with ARM7 is shown below. The connection of LCD to ARM is to display the updated information.

//code snippet of LCD interfacing to ARM

```
IOCLR0=0x00FFFFFF; IOSET0=x; //IOSET0=IOSET0<<16;

IOCLR0=0x00004000; //RS // IOSET0=x;

IOSET0=0x00008000; //EN

delay(); IOCLR0=0x00008000;} //EN

void lcddata1(unsigned char y)// to send data

IOCLR0=0x00FFFFFF; IOSET0=y; // IOSET0=IOSET0<<16;

IOSET0=0x00004000; //IOSET0=y;

IOCLR0=0x00008000;
```

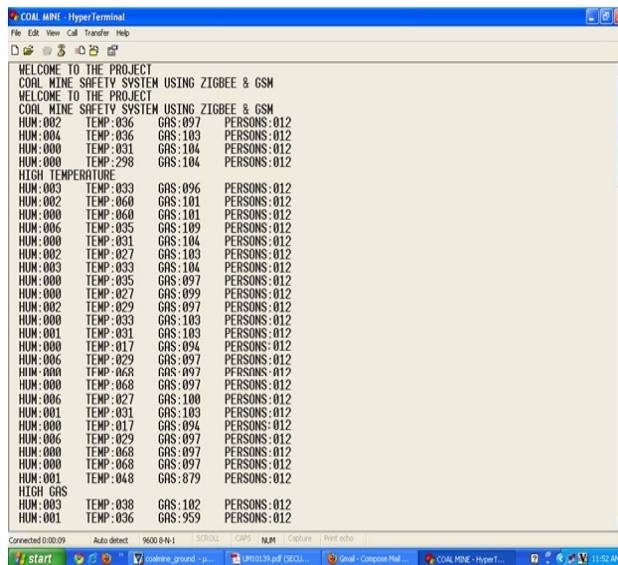

Figure (v) Hyper Terminal Results in PC

5. SECURITY MANAGEMENT SYSTEM – GUI

The above figure (v) is the screen shot of the Hyper Terminal when system is connected to PC through Serial Port.

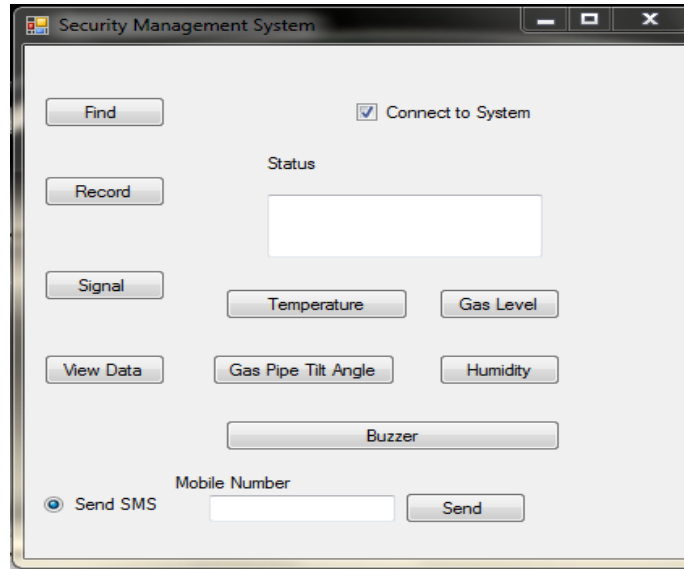

Figure (vi) Graphical User Interface

The GUI is useful for a user to interact more with the system. A user friendly UI is designed to access the security management system easily. Individual buttons are provided there to find the current status, to get the signal strength. The data will be displayed in the provided space with in the UI. Record button is also provided to capture the data which is useful to keep record of the industry's information over a period of time. The view data is to verify or analyze the already recorded data. Separate buttons are provided for each sensor input to monitor the each parameter individually. The gas pipe line tilt also measured and displayed in the available space. With the help of this GUI, user can send SMS directly to a number.

The following code snippet is to enable serial port

```
//enable serialport1(serialport1,open())  
buf(0) = "!"//declare as char  
SerialPort1.Writ (buf, 0, buf.Length)  
tx = TextBox1.Text//where we enter the text  
buf = tx.ToCharArray()  
SerialPort1.Write(buf, 0, buf.Length)
```

6. RESULTS

The end results of the system from hardware perspective are shown in below figures. The LCD displays the current status “Sending SMS” in below stated example. This type of automation is very helpful to maintain the security across the Industry. The same development is applicable to all types of industries or coal mines. With the use of GUI, simplified access is achieved.

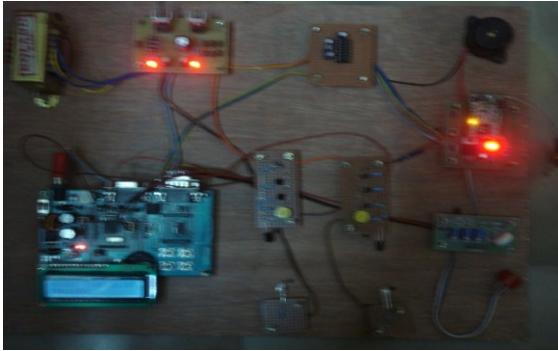

Figure (vii) connections of Hardware modules Figure(viii) LCD Screen Displaying Message

A method of designing a coal mine safety system based on Zigbee wireless sensor network was designed and demonstrated. In this application, as we are storing the values of the parameters in the PC, the stored values can be used to detect the hazards before they happen.

As we are giving the information to the personnel regarding the measures to be taken in case of a hazard, it will be useful for them to save their life before any one comes and help them to come out of the mine.

7. CONCLUSION

The project can be extended by monitoring the health conditions of the personnel entering the mines, if the personnel health condition is abnormal, then he will not be allowed to enter in to the mine. The parameters monitored on the PC will be analyzed and we can also predict the hazard before it actually happens. Since the automation process also includes the design of GUI, user can easily access the system and has facility of storing the data.

Video monitoring is a special additional feature which can be added to extend the project to watch remotely located site in live. The same GUI is useful in this extension.

REFERENCES

- [1] YuLi-min, LiAnqi, SunZheng, LiHui. Design of Monitoring System for Coal Mine Safety Based on Wireless Sensor Network. Mechtronic and Embedded Systems and Applications, 2008. IEEE/ASME International Conference, 12-15 Oct, 2008.

- [2] Yang Wei, Huang Ying. Wireless Sensor Network Based Coal Mine Wireless and Integrated Security Monitoring Information System. Networking, ICN '07 Sixth International Conference, 22-28 April, 2007.
- [3] Mohammad reza Akhondi, Alex, Simon Carlsen, Stig Petersen. Applications of Wireless Sensor Networks in the Oil, Gas and Resources Industries, 24th IEEE International Conference on Advanced Information Networking and Applications, 2010
- [4] Guo Yongling, Wang Qianping, Huang Hai, Tan Wei, Zhang, Guoxia. The Research and Design of Routing Protocols of Wireless Sensor Network in Coal Mine Data Acquisition. ICIA
- [5] Gang Ding, Sahinoglu Z, Orlik P, Jinyun Zhang, Bhargava B. Tree-Based Data Broadcast in IEEE 802.15.4 and ZigBee Networks. Mobile Computing, IEEE Transactions, 2006, 5(11): 1561-1574
- [6] Xiaodong Wang, Xiaoguang Zhao, Zize Liang, Min Tan. Deploying a Wireless Sensor Network on the Coal Mines. Networking, Sensing and Control, 2007 IEEE International Conference on 15-17 April 2007: 324-328.
- [7] Mo Li, Yunhao Liu. Underground Structure Monitoring with Wireless Sensor Networks. Information Processing in Sensor Networks, 2007. IPSN 2007. 6th International Symposium on 25-27 April 2007: 69- 78
- [8] Andrew N.Sloss, Dominic Symes, Chris Wright, ARM System Developers Guide - Designing and Optimizing System Software.