

Electrical *ANN* Circuits (1-ports) and Schrödinger's "*What is Life?*"

Emanuel Gluskin

Ort Braude College (Carmiel) *and* the Kinneret College
on the Sea of Galilee. Israel.

gluskin@ee.bgu.ac.il
<http://www.ee.bgu.ac.il/~gluskin/>



In his book (brochure) [1] "*What is life?*" Erwin Schrödinger widely uses the terms of "entropy" and "structure", trying to simply define the physical essence of life.

Though [1] is a problematic work with internal corrections and numerous apologies, i.e. not formal science, just some ideas, the most important concepts involved, structure and complexity, are sufficiently clear for drawing the attention of system specialists to [1], and even for continuing the line of [1].

Sadi Carnot (1824) studies the *transfer of heat to mechanical work*, with the stress on reversible processes, and **Rudolf Clausius** (1865) *defines entropy* for such processes:

$$S = \int \frac{dQ}{T} \quad (S = \int \frac{\delta Q}{T}) \quad (1)$$

and shows that such an integral always increases in an isolated system.

In thermodynamics, the integration is over the volume of a system composed of some distinguishable subsystems (parts with different temperature), or over the track of the/a system undergoing a work-cycle.

Note: **Heat-Work** (engineering) → **Energy-Entropy** (theory)

Consider the role of temperature in (1) for comparing, in terms of entropy, the classical and quantum (!) light sources:

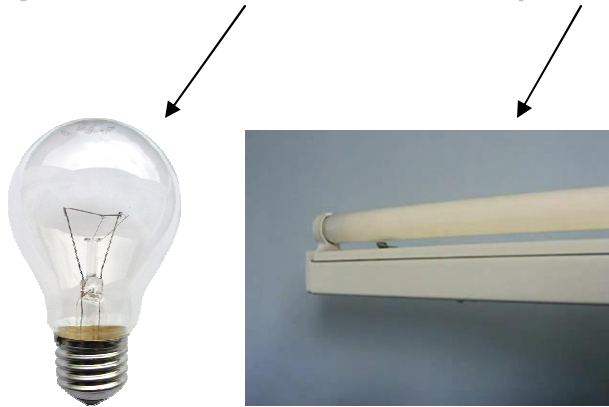

$$T_1 \gg T_2$$

For the entropies of the emitted lights be different not very strongly, we must have the emitted heat smaller for the fluorescent lamp. That is, the power efficiency of this lamp is higher.

4

As well:

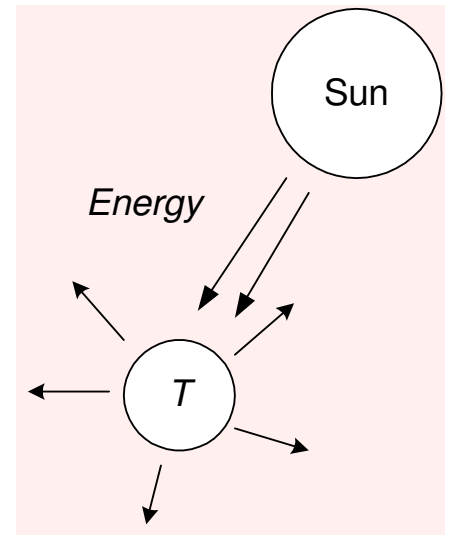

How does human activity influence the thermodynamic entropy of the Earth? [Contrary to simple animals, the place of human in Nature is seen only on a wide scale.]

Ludwig Boltzmann derives (1872-5) the formula:

$$S = k \ln P \quad (2)$$



in which P is the number of system states related to the same energy of the system; "probability." This is close to modern definition of entropy.

To connect (1) with (2), consider that the small δQ , appearing in $dS = \delta Q/T$ means **addition of some disorder** to that of the system, **but T is also associated with the system's disorder**; thus for dS considered as some measure of the *relative change* in the total disorder:

$$dS = \frac{\delta Q}{T} \longrightarrow dS \sim \frac{d(\text{Disorder})}{\text{Disorder}}$$

from which

$$S = a \ln(b \text{Disorder}) \quad (2a)$$

with constants a and b (the latter due to the integration) to adjust (2a) to (2).



Let now x (or \vec{x}) be a parameter of a system's state, so that $S = S(x)$, and describe in $S = k \ln P$ the entropy near its maximum as:

$$S(x) \approx S_0 - \alpha(x - x_0)^2 \quad [\text{rather, with } \vec{x}]$$

($\alpha > 0$). Then, it is readily seen that the tendency $S(x) \rightarrow \max$ means a *Gaussian distribution* of the probabilities, for $|x - x_0|$ not large:

$$P \sim \exp[-(\alpha/k)(x - x_0)^2].$$

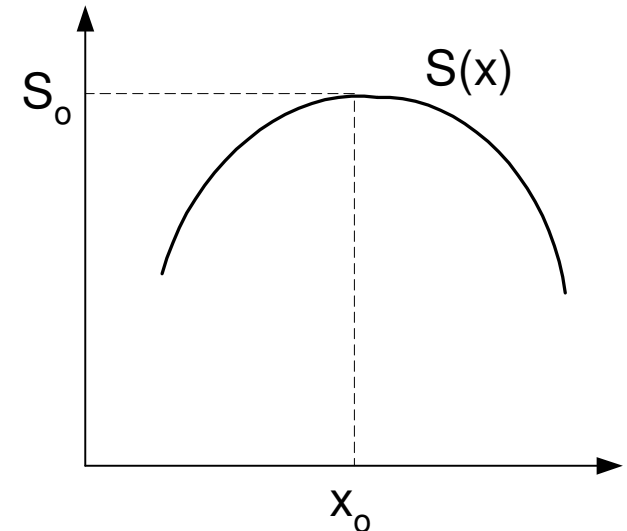

Thus, a Gaussian distribution relates to a system which is *close to a thermodynamic equilibrium state, which is not life*. Thus, this distribution (as any other statistical) is poorly relevant to the concept of life.



In general, $S \sim \ln P$ is the best math relation here, but the complexity associated with P should be understood more as some “**structural possibility**” than “statistical probability”, and, of course, Boltzmann’s k , connecting the energy and temperature units, is not needed.

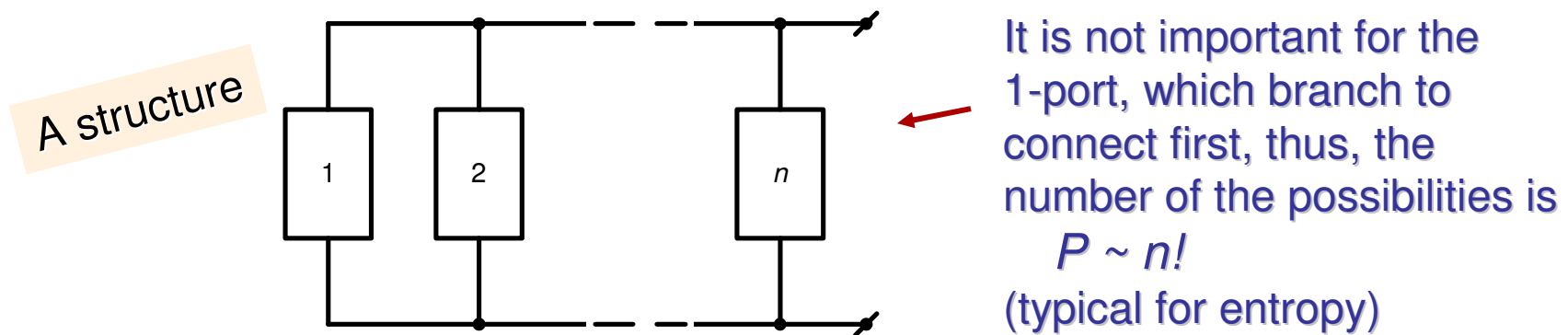

Scanning a structure as a picture, and transferring the obtained signal, one can use the “entropy” of the theory of information ($-\sum P_k \ln P_k$). Thus, we can, in principle, speak about “entropy of structure” via a signal.

In fact, “structure” *per se* is a kind of spatial signal.

7 However, we shall **not** try to give any formal definition of “structural entropy”, and shall speak about **structural complexity which is an intuitively clear concept.**

Entropy became the most important, after *energy*, theoretical characteristic of thermodynamic and statistical systems.

Today (Landau & Lifshitz, *Course of Theoretical Physics, vol. V.*), temperature is *defined* via S as

$$T^{-1} \equiv dS / dE \quad (3)$$

E is energy

in *thermodynamic equilibrium*.

If $E(T)$ is known (as it is for radiation, in Plank's research), then definition (3) becomes a constructive equation.

That T^{-1} and not T is defined, means that we have $S(E)$, but not $E(S)$. Indeed, energy is a simpler concept than entropy, just as n is simpler than $n!$, and $E \sim n$ can define $S \sim \ln(n!)$, but not conversely. That is:

$$T \equiv \left(\frac{dS}{dE} \right)^{-1} \leftrightarrow \frac{\partial E(S, ?, ?)}{\partial S} \quad (\text{not } \frac{dE}{dS}).$$

Without this connection, we could not define *physical signals*, *always associated with movement of energy*. Just for such signals, the theory of relativity states the limitation, $v < c$, on the velocity.

However, any signal is something ordered, some information, -- a border for disorder, i.e. any physical signal is both some negentropy and some energy.



Plank's contribution that had to influence Schrödinger (1887-1961) NDES

Max Plank approaches radiation as a full-rights thermodynamic object, and (since about 1897) applies entropy to the study of EM radiation.

The idea to introduce a new **descriptive tool** for a difficult problem, and thus to advance the theory (here, using the pair **Energy-Entropy**), is very instructive.

“The goal of Science is not to explain natural phenomena, but to describe them completely and as simply as possible.”

Gustav Robert Kirchhoff (from the introduction in “Mechanics”)

This is the way our babies try to learn the world (their “descriptions” are recorded in their mind), and this is a **healthy way** for us to go.

However, the competitor to Schrödinger's [1], academic biology, hardly can describe life ***“completely and as simply as possible”***.



In **1944 Schrödinger** publishes “***What is life?***” [the whole text is found in Google]; **Sections 6 and 7** relate to our topic (“**[1]**” means these sections).

The main insistence in [1] is ***that***

what is important regarding our feeding (eating) is not that we receive energy, but that we receive negative entropy. The negentropy provides life.

According to A. Sommerfeld [*Thermodynamik und Statistik* (1952)], astrophysicist Robert Emden insisted [Nature, 141. 908 (**1938**)] that entropy in the natural processes is **more important** than energy, i.e. Entropy is the “director” in the Nature, and Energy is the “accountant”.

Presumably also motivated by the use of entropy in Plank’s research, Schrödinger applies the position of Emden to understanding the essence of life.

We shall consider Shrodinger’s position using *the concepts of structure and complexity, and not only on the sense of physiological digestion, also the intellectual “one”*.

We do **not** directly receive "negentropy", i.e. some more order, with the food. We receive the **possibility of making the order (i.e. of generating neg-entropy).**

Namely, the body gradually includes the new molecules, received with the eating, into the existing structures, thus reducing the entropy of the intermediate system enlarged by the new molecules :

In this modeling, energy is important for reduction of the entropy.

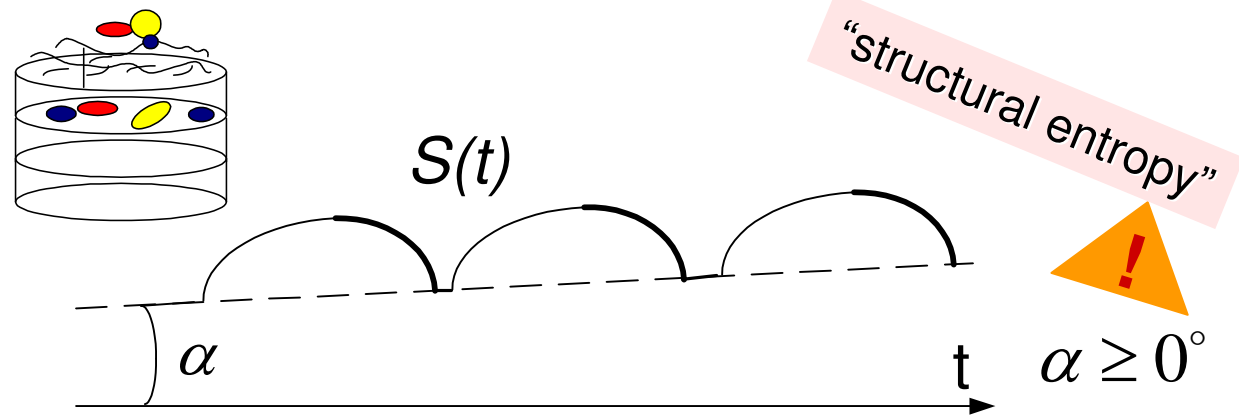
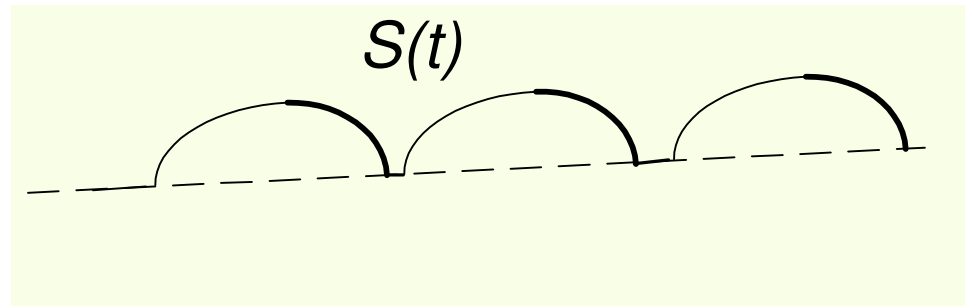

Fig.1: The entropy of the body in time; each "pulse" relates to a meal; the body's action is to decrease the entropy.



(Fig.1:)

This constructivism even makes the connection of negentropy and life – the thesis of [1], -- a matter of **elementary logic**.

Indeed:

If one's body *succeeds in decreasing the entropy* by “absorbing” the added molecules, then, obviously, *the received food well fits the body*, i.e. one's (physical) life is ensured. Thus, life indeed “is” negentropy.

[Also in the intellectual aspect. NB]

When referring below to “the position of [1]”, we shall always mean the process illustrated by Fig.1.

In other words, we understand the thesis of [1] as:

“Life is an oscillating preservation of entropy (complexity) at not too high an average level, by some (inherent for the living body) structures (that may be **logical**) having material, energetic, and **informational** exchanges with the surrounding medium”.

The principle is to recover (stand up) and continue.

Thus, in view of [1], the symbolic scheme arises:

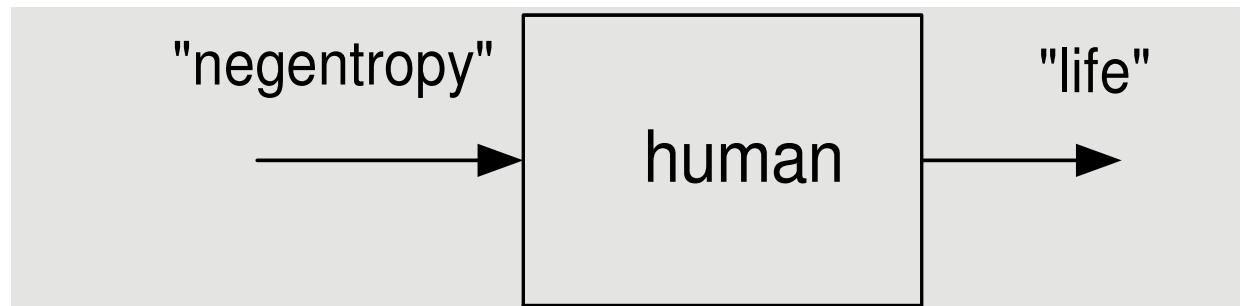

In “systems” we always have the opposites: *TI-TV*, *Linear-NL*, *Stable-Unstable*, etc..

If the entropy is not decreased, it is increased, i.e. **life - death**.

The entropy conditions for the “death” can be demonstrated using a *piece of paper*:

Let one try to remember a symbol written on a page, by **stretching** out a piece of this page (paper) with this symbol, and keeping this piece in his purse.

Because of the very complicated “hairy” form of the boundary, the “structural entropy” of the piece is significant.

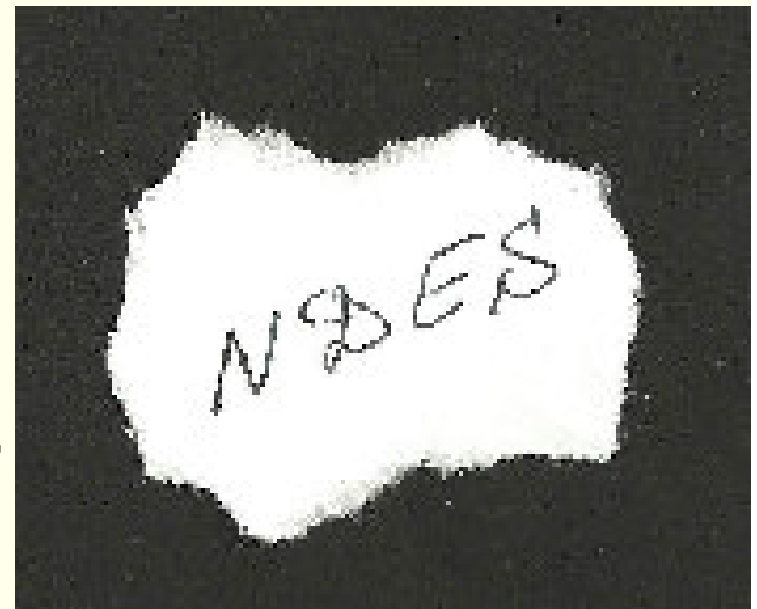

The “ill” peace of paper with the needed symbol, to be treated.

E. Gluskin, "ANN **The structural entropy of the subsystem "kills" the piece of paper** NDES 2012

One's experience shows that the life of such a stretched piece in his purse will be short, because the new stretches can easily **start just from the boundary.**



By the same reasons, the physical strength of crystals, e.g. of NaCl, strongly depends on the smoothness of their surface. That is, high entropy of the surface "kills"/destroys a stressed crystal. Energy of the source of force that causes stress, is important here.



Observe that structural entropy of a subsystem (here, the surface) can influence entropy of the other parts. (This is somewhat similarly to temperature equalization.)

On the reduction of entropy. NDES'12

High (structural) entropy

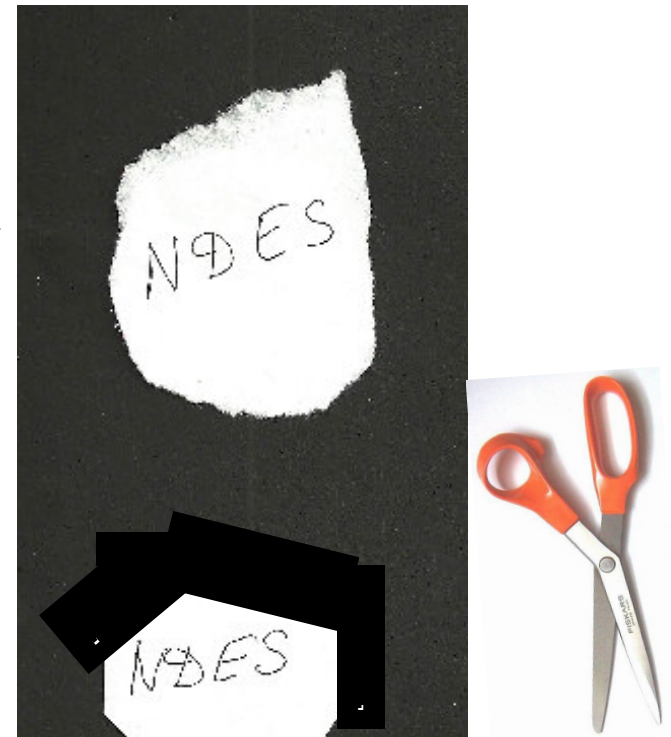

Now the entropy is reduced by the scissors, which *helps*, but one can think about other ways of entropy-reduction, **because our body and mind have no scissors.**

If the molecules could propagate on surface of the piece of paper from the periphery toward the centre, and find on the way “their places”, then we would have some analogy to the digestion of food, i.e. absorption of the molecules by a biological structure.

Trying to define structural entropy, invent a game where the winner is the one who “collects” more neg-entropy by arranging some hard pieces of a prescribed number.

Consider the thesis that a country is “alive” if its ***traditional*** structures absorb proper people, arranging places of work for them.

Define statistical entropy of a dancing crowd.

So how does entropy "kill" us ?

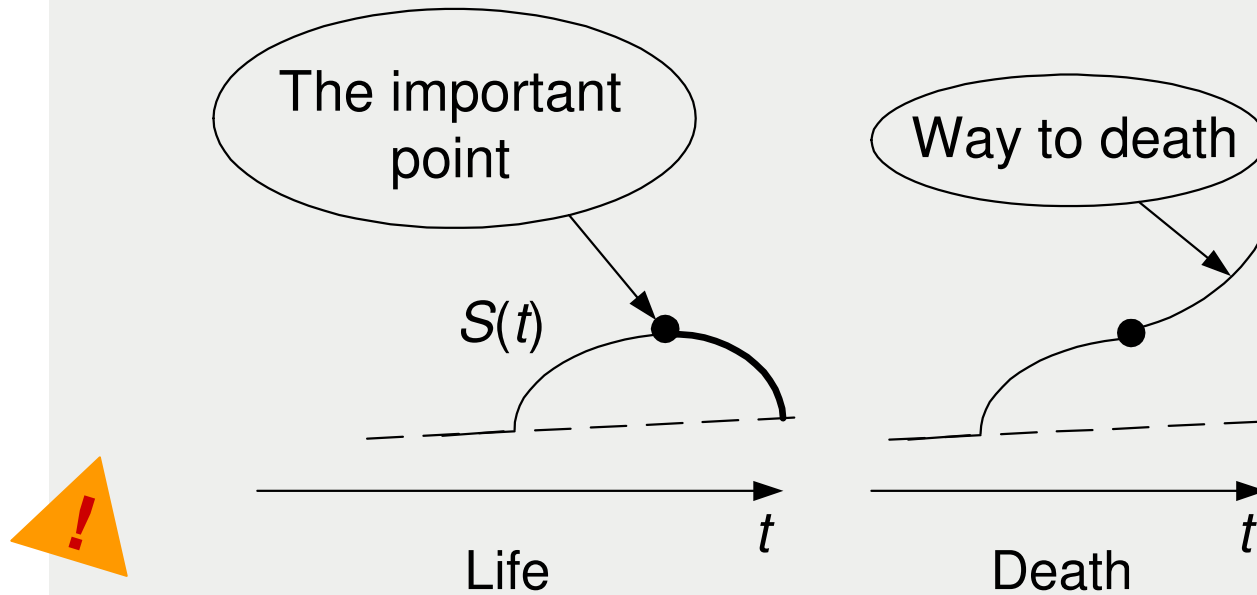

Here, the body fails to do its job, and an excess of the structural entropy wins the battle. (Think about intellectual food.)

[1] says: "**Maximal entropy means death**".

This is too undefined, the concealed statistical meaning (thermodynamic equilibrium) is strange; simpler for us, is the prosaic formulation, also related to entropy :

Stopping the internal maintenance and growth of the structures means death. (Living body may not grow, but there always is an internal maintenance of the structures.)

Generally, the new molecules supplied by feeding can appear either on the surface **or** inside the structures of a living body, to be then, in either case, "absorbed" by the structures as needed.

To have a living model, let us assume that the new molecules always are **on the surface** of a structure seen as a kind of "spine" that grows up by one "vertebra".

The local molecules' EM fields "instructing" the new proper molecule, in terms of the potential energy.

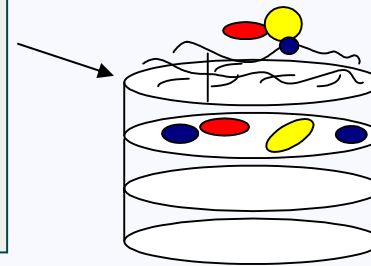

With this simple picture, we start a **symbolic circuit modeling** by observing that an *algebraic concept* can be applied to the description of a formation of a structure. The points of the modeling are: **simplification**, i.e. reduction of the entropy, and "**instructing**", i.e. knowing what to create. In biology, this instructing information is initially in genes, then in growing babies.

In the following symbolic model of a structure, which starts from mentioning the (algebraic) *ideal*, the physical specificity of the objects being compared is ignored as much as possible.

In terms of *sets*:

Q – is *ideal of P* if:

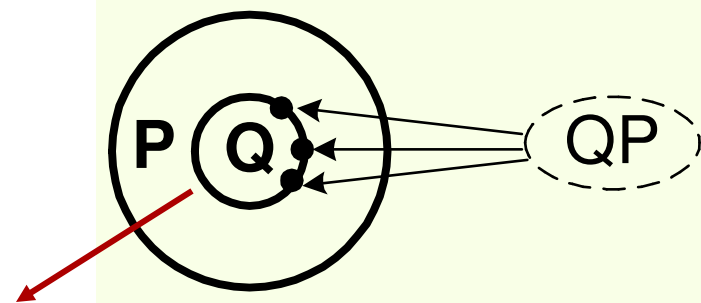

$Q \subset P$ and $QP \subset Q$ -- "**absorption**".

Let us see here a reduction of complexity, entropy ... a structural simplification, and try to employ "ideal"

The concepts of: "ideal", "ring", "algebra", "field", -- **all sets with function multiplication** -- are rarely mentioned in linear circuit theory and mechanics, which contrasts to the wide use of "groups" in physics.

The reason for this distinction is that in physical "groups" we multiply operators, i.e. **physical operations (actions) on some objects, e.g. rotations**. This is not associated with any dimensional (physics units) change.

However the **arithmetic (function) multiplication** involved in "ideal", "rings", etc., causes the dimensional problem (see some details below), and thus mainly belongs to **nonlinear theories**, though in the nonlinear field this situation is also not considered.

This justifies the fact that **we shall replace the arithmetic multiplication in ideal by a design operation simplifying a circuit**. Such a nonscientific "informational" step, ascribed here to "Thevenin's Technician", has some parallel to "Maxwell's Demon", -- both of the gentleman know what to do, just for our Technician it is more important to be sober.

The dimensional problem with the **arithmetic multiplication** :

$$Q \subset P$$



$$QP \subset Q$$



If this is true, then this (with the *usual multiplication*) is *impossible* by the dimensional reasons ($x + xx + \dots$), and if one uses nonlinear forms $f(x) = ax + bx^2 + gx^3 + \dots$, adjusting the dimensions in the supporting numerical set (a, b, c, \dots) to those in the function space, then $a + b$ becomes impossible, i.e. the numerical set is not “field”.

Thus, we replace the arithmetic multiplication by the **process** of a physical absorption on the biological side, and **simplifying design operation** on the circuit side.

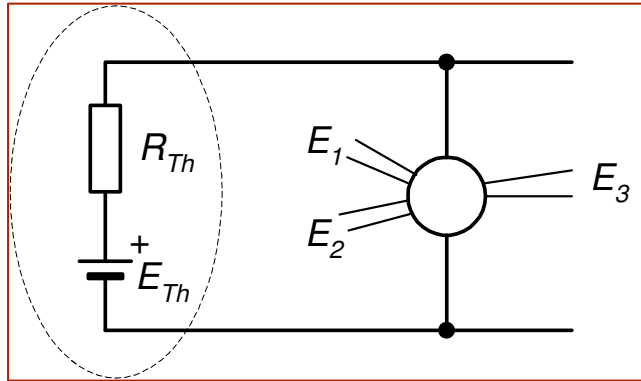

$$QP \subset Q$$

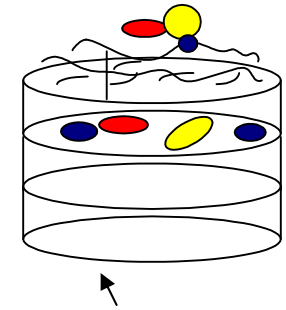

Information from genes

Note that $QP \subset Q$ (or simply QP) is a *process* here, not a usual algebra related to fixed constructions.

The “ideal” Q
(an important
part of P)

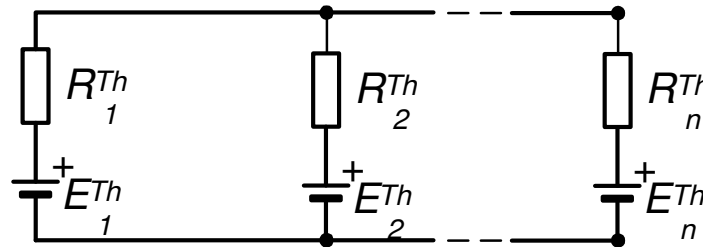

-- **How many branches do you want to have?**

-- As many as is needed for the biological modeling. Note that the *energy* of the whole initial set of circuits (of the batteries) is meant to be *accumulated* in the “ideal”, despite the structural simplification.

The technician creating Q , should be compared with *Maxwell's Demon* who also decreases some entropy (though in a statistical process) *by his own hands*.

The Demon's action (decrease of the statistical entropy)

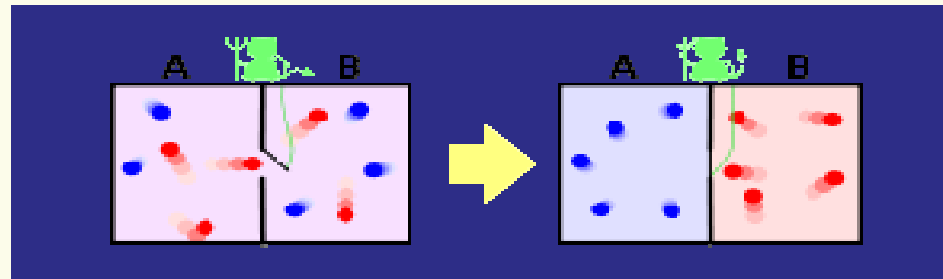

More gas can be added, from time to time.

The Demon: looks around and selects, making some order/structure in the state-space of the statistical ensemble, not changing this ensemble.

The Technician: looks at a correct place in a parallel connection and, considering the chosen port (output) of the given circuit, simplifies this circuit according to the given (the first) branch, or at least connects the two chosen interval in parallel to the already existing connection.

In both cases, some "know how" information helps the heroes to reduce the complexity of the physical system, i.e. its entropy, as is needed for life.

This unrealistic hero, very bravely (just dangerous for the reputation, -- why, for instance, does the academic biology not imagine in us different demons?!) introduced by Maxwell, later led Leo Szilard (1931) and Claude Shannon (the latter in 1948; some very important theories) to understand the connection of information with **neg**-entropy.

It seems that Maxwell felt the importance of the informational aspect in matters of entropy, and this his brave “non-scientific” step was at least very motivating.

Let us proceed with the ideal Q in terms of Thevenin’s 1-ports in the context of **affine nonlinearity (ANM)**, as it was used in the previous lecture.

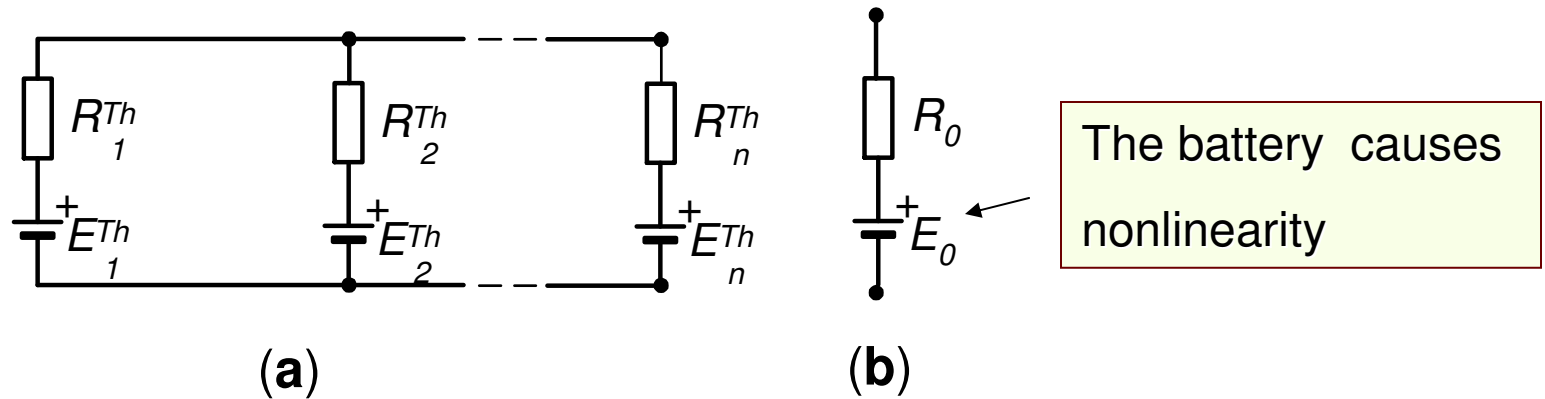

For $v = Ri \pm E$ we define the *measure* of the affine nonlinearity as

$$ANN^e \equiv \frac{E}{Ri_o} \quad (\text{'e' means "entropy"})$$

with some standard i_o . In particular, for Fig. (b) it is

$$ANN^e = \frac{E_o}{R_o i_o}$$

where

$$E_o = \frac{\sum_{k=1}^n (E_{Th k} / R_{Th k})}{\sum_{k=1}^n 1 / R_{Th k}} \quad \text{and} \quad R_o = \left(\sum_{k=1}^n 1 / R_{Th k} \right)^{-1}.$$

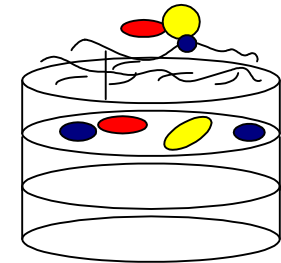
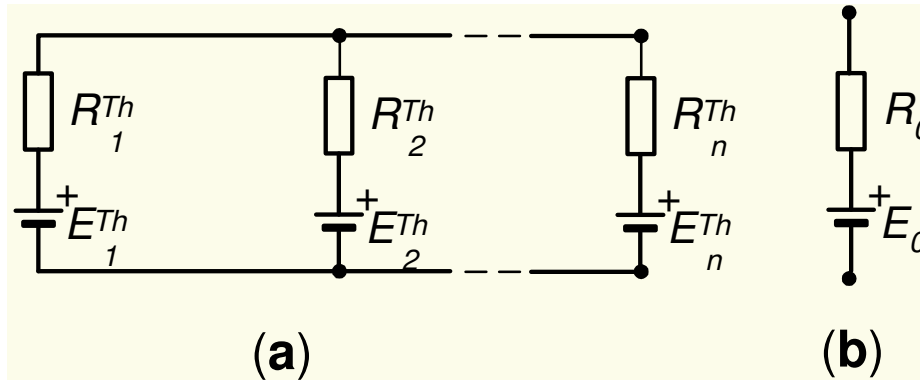

For the simple case of all E and all R in Fig.(a) similar, we have in (b):

$$E_o = E, \quad \text{and} \quad R_o = R/n$$

and thus for the whole connection

$$ANN^e = \frac{E_o}{R_o i_o} = n \frac{E}{R i_o} \sim n.$$

For the total energy W accumulated in the batteries, we have

$$W \sim n \sim ANN^e$$

However, the number of the permutations of the n branches is $n!$, and thus for $n \gg 1$ we observe that for the typical for S factor:

$$S \sim \log n! \sim n \log n \sim ANN^e \ln ANN^e.$$



Assume now that R_k are different, and E_k are also different.
In what degree the relations

and
$$W \sim ANN^e$$

$$S \sim ANN^e \ln ANN^e$$

remain correct?

[Left for the listener]



Recalling my previous Lecture (this Proceedings), we note that, in fact, for the analytical side, the actual circuit (Thevenin) simplification is not needed.

We just have to choose one of the ports, and this choice can naturally occur if the new added circuit touches (maybe randomly) the already existing parallel connection by two of its terminals so that the terminals become connected. Then, the process can be more random and Thevenin's Technician is not needed. But this touching can be also done by the Technician.

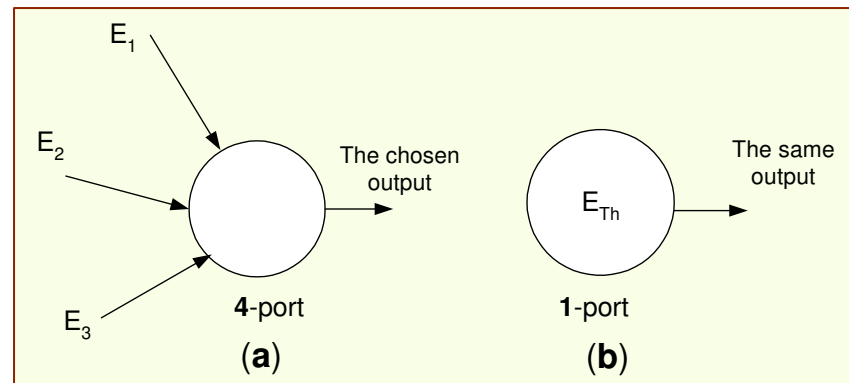

Informational "Feeding"

What is needed?

1. Periodic decrease of entropy of our mind. ("Relax!")
2. Harmony in the development of the brain's hemispheres.



Our life is not just animal physiology, it also has an intellectual aspect, to be described in the same basic patterns and terms.

We shall die if we do not simply understand and control ourselves also in the intellectual plane, and system theory, -- a very important science for the future, -- should help here.

The simple "digestion-argument", motivated by [1], opens an interesting degree of freedom also in the intellectual aspect.



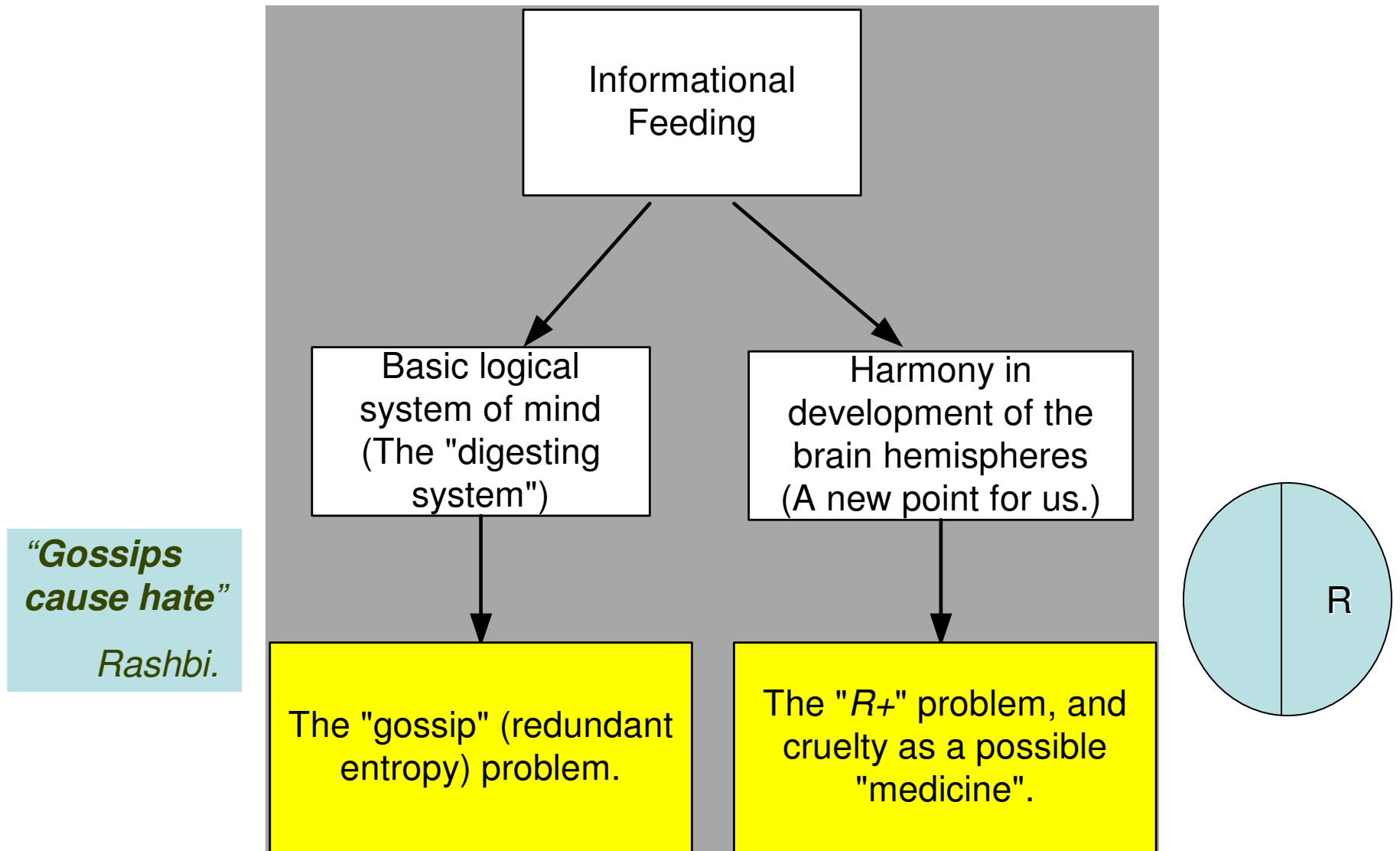

A wrong feeding and the response

If some wrongly prepared food is indigestible for the child, then the entropy of the intermediate set of molecules cannot be decreased by the digesting;

Our first hypothesis is that the strange, not understood "*days of violence*" are most directly associated with the *improper, untreatable by many, intellectual feeding.*



This nice baby is not connected by common opinion with other infants. However, in the future the spoon becomes *{Radio, TV, Internet, ...}* that abundantly feed us with the same mistakes, and the child becomes one of those who know how to organize themselves and protest.



"I neither understand, nor need all this information (knowledge). I was not given perception and memory for this.

The relation to me of the means of information (radio, TV, Internet) is just a hooligan one! (They feed me with nonsense.)

All this redundant gossip causes me to be depressed and to protest.

I am afraid of the society, and attack it in order to feel more confidence in myself.

They define me as 'hooligan', but something bad and frightening occurs inside me, because of them.

³⁶
I want to remain simple!

This simple and nice guy stops to understand himself, but we have to understand him and help:



"Scream" [fragment] by Edvard Munch (1893)

The 'Days of violence' :

"I want to remain simple and be thus respected. I have to generate my SOS-signal in this terrible noise!

Violence makes all simpler!"

“Gossips cause hate”

“Rashbi”

A bit of ancient
philosophy

[Rabbi *Shimon bar Yochai*, **1st** or **2nd** Century, AC; the central figure in creation of the Kabala].

In the modern context:

Indeed, we have to keep our good and reliable communication ability with our close environment (as the family), to concentrate at work, when driving car, etc., -- and all this may not be spoilt by making our mind poorly logically organized, by having too high an entropy of our thoughts.

The problem is the redundant (“interesting”) information that we receive almost “by force”. (Note that such feeding itself is a hooliganism!)

Healthy “digestion” of the received information, and keeping a low entropy of the logical system are much more important than receiving a lot of information, just as with regular food and the physiological digestion.

Immanuel Kant :

“Novels must be pulled out of the hands of children because the children cannot correctly understand their contents.”

What would say Kant when seeing that today a small child with the developing brain that honestly tries to understand everything seen, -
- is watching the announcements quickly jumping on the TV screen?!

More about the “gossip problem”:

E. Gluskin, “An argument regarding the nature of hooligan behavior”,
DIAL PHIL MENT NEURO SCI 2012; 5(2): xx-xx. In press,
see at: <http://www.crossingdialogues.com/Ms-C12-01.pdf>.



Alas, we have one more "feeding" problem!

This time, the mom, wishes to have a **fattened baby**, and gives him too much food (good food).

When we turn to informational feeding, this nice "lapsus", that seems to be easily solvable by the usual-digestion physiology (though it can cause diabetes) may lead to a great social tragedy!



In the informational field, the “fattened-baby problem” means an **intellectual overstress** in the population, caused by ambitious intellectual challenges given to the society.

The danger is associated with the fact that the hemispheres of our brain have very different functions.

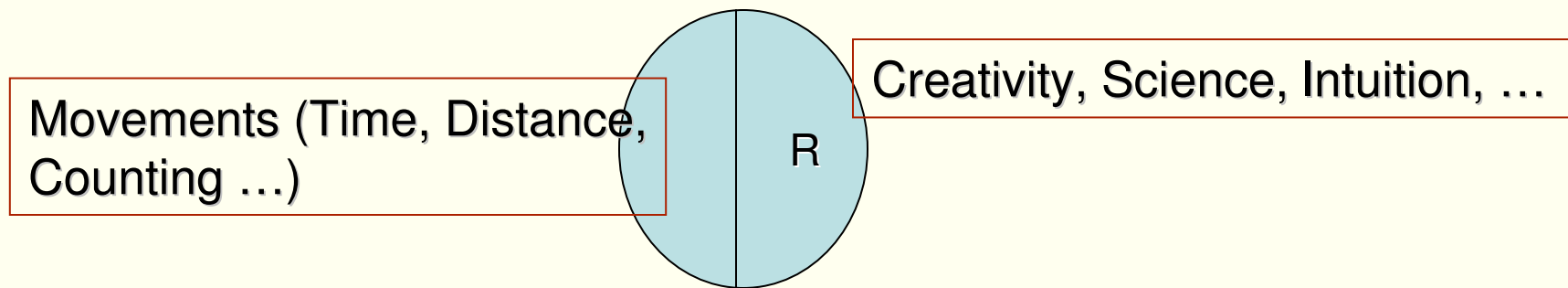

Why (what for) are the brain functions so macroscopically separated?

Presumably, for letting us **feel** the **unbalance** in the development of the hemispheres, and thus control our intellectual state dependent on these functions.

When occurring in many, this unbalance can be a great trouble.

Especially dangerous is the case of “**R+**”, i.e. overdevelopment of the right hemisphere, -- the meaning of the “fattened-baby”.



(R+) According to the hypothesis of

E. Gluskin, "Cruelty as the "medicine" treating an unbalance in the development of the brain's hemispheres",

Int. J. of Neuroscience, 119:8 (2009), 1150 – 1154 :

people feel some organic necessity in making the balance between the development (or activity of) hemispheres [probably simply because of the different level of electrical excitation and, thus, of unusual voltage or charge distribution], i.e. further **development of the right hemisphere has to be stopped**. [Note: just a development, – in itself a positive feature -- can be expressed as a mental disease!]

This **stopping** may require (be most simply provided by) cruelty as the "medicine" given by an uneducated ruler.

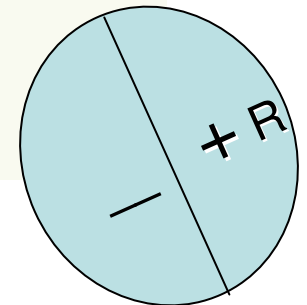

I became afraid of myself. With all these intellectual overburdens, I get some mental problem, and many of my friends have got it already.

I do not want to become cruel, to kill people and be killed myself, but cruelty is the most simple and sure way to stop this too difficult for me creative thinking process.

Why did this good friendly society become a society of geniuses, forcing all the others to form (become)

a kind of **tiger**^(*)?

This guy starts to be afraid of himself:



(*) This "tiger" is R_+

Remark: Science is beautiful and challenging, but when to stop and start with maintenance of the simple mind? (Recall the entropy oscillations in Fig.1.)

In order to see the **importance of the topic** consider that today **huge human masses begin to be switched to intensive industrial and scientific development on a world-wide scale.**

Via system science, the technology and the philosophy of surviving will have to become more connected. If one sees modern **system science** as a part of human culture, then the social and spiritual health problems revealed by the line of thought started in [1], are relevant to him.



Study and respect the basic limitations and requirements of human thinking abilities.

Remember that these limitations and requirements, observed in "many", are given to us by Nature, and will remain forever. Life is preservation of the structures, including those logical, associated with the intellectual life, and destroying these structures, we kill ourselves.

Give the mind (just as you give your stomach) only what it can normally "digest". Respect the intellectual simplicity that gives robustness to life.

Never put intellectual challenges before any nation. Let any human himself find such challenges according to his abilities. Avoiding R+, you avoid numerous appearance of hooliganism [different forms of cruel behavior], simply because humans will not *need* cruelty for solving the problem of R+, i.e. for stopping the internal intellectual activity.

Never believe that human hooliganism is a result of only bad social welfare, -- it is, first of all, a mental disturbance caused by the hooliganism of the scornful attitude of the "educated" society to the simple individual.

Periodically make statistical tests of the brain activity of the population and properly limit the intellectual stresses on the society.

Consider the social dangers with religious authorities, seeking their help.



Simple people can be against culture (and this can be accompanied by killings) if this culture does not respect them.

Never "development for development", i.e., demonstrations of the "power" of human "wisdom" should not be the goal.

We need the science *only for ourselves*. The Nature (God) does not need our science at all; electrons knew what to do before Schrödinger's equation was written.

Thus, we should not use our studies for depressing ourselves.

Simple structures better survive which is the essence of life. If the educated society has chances to destroy itself, then the way we go is not that of life, but of some unhealthy euphoria. Simple people can understand all this better than the educated ones, and they can **and will** express their opinion very sharply and painfully.



E. Gluskin

“ANN Circuits and “*What is Life?*”

NDES 2012



End