

3-Dimensional String based alternative particle model.

Leo Vuyk,
Architect,
Rotterdam, the Netherlands.
LeoVuyk@Gmail.com

Abstract,

In particle physics it is an interesting challenge to postulate that the FORM and structure of elementary particles is the origin of different FUNCTIONS of these particles.

In this paper we present a possible solution based on complex 3-D ring shaped particles, which are equipped with three point like hinges and one splitting point, all four points divided equally over the ring surface.

The 3-D ring itself is postulated to represent the “Virgin Mother” of all other particles and is coined Higgs particle, supplied with the 3-hinges coded (OOO), which gives the particle the opportunity to transform after some sort of mechanical collision with other particles into a different shape, with a different function.

Thus in this Quantum Function Follows Form theory, the Higgs is interpreted as a massless transformer particle able to create the universe by transform its shape after real mechanical collision and merge with other shaped particles into complex and compound knots.

Introduction,

It is assumed that the vacuum is seeded with massive numbers of massless Higgs particles, all energetic oscillating inside a chiral vacuum lattice system and as such the origin and bearer of all energy in the universe. (reference: 1)

If by a local energy excess, two Higgs particles collide with enough energy, it is assumed that at first an electron and positron emerges by the transformation of the two Higgs particles.

Due to the propeller shape of the Fermions, these Fermions start to spin by a constant collision and scattering process with the Higgs vacuum, changing Higgs particles continuously into different forms of Photon/Gluons.

As a result, we found, that many “elementary” particles should not be elementary, but compound constructions or KNOTS of transformed Higgs particles.

Even the Muon and Tau Lepton should be compound particles having the same shape as one of the different coloured “naked” Down- respectively Charm Quarks. (figure: 6)

Thus, Muon- and Tau particles seem to be naked Quarks!

ALTERNATIVE STANDARD MODEL

of elementary (single) particles with click-on potentials to form compound Quarks- and Leptons.

Explanation of the codes:
 U= Up rotation (180 degrees)
 O= Unchanged circle.
 L= Left rotation (90 degrees)
 R= Right rotation (90 degrees)

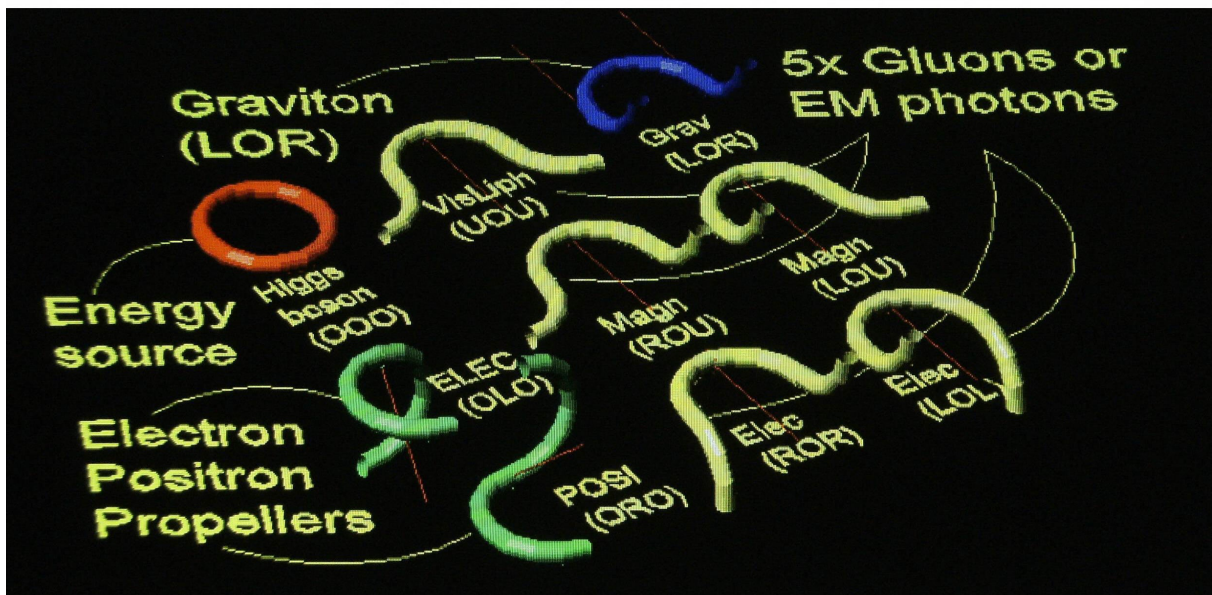
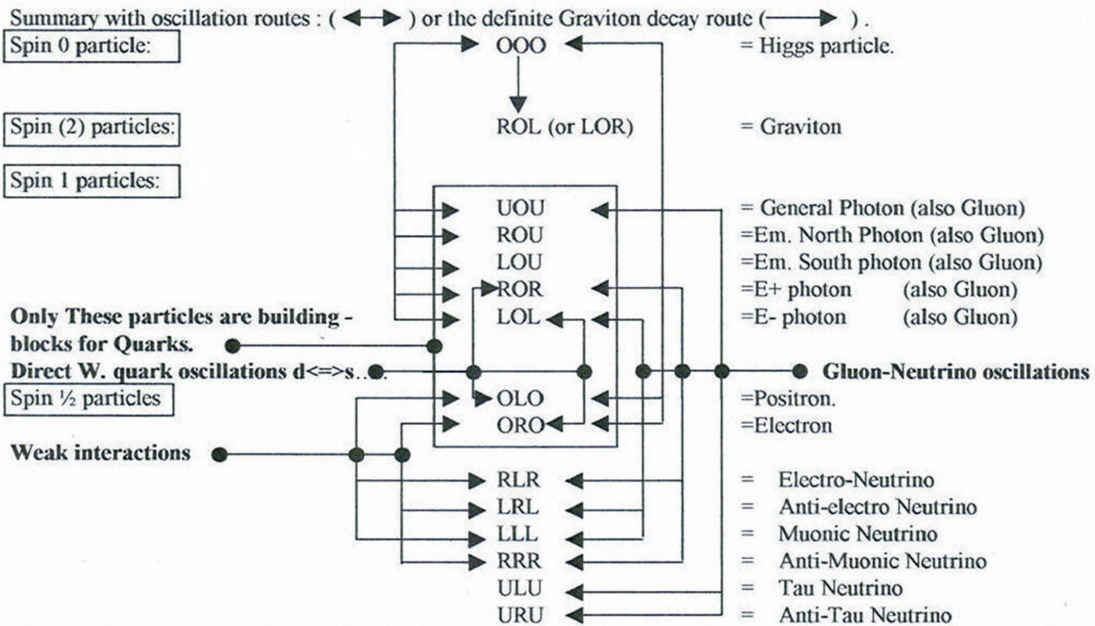
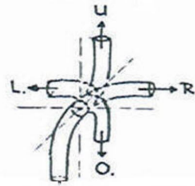

Figure 1, 3D image of Basic Singular Particles;
 ONE Higgs boson (OOO), TWO basic single mirror symmetrical Fermions: the Electron and Positron (OLO and ORO), ONE Graviton (LOR), TWO sets of mirror symmetrical monopole Gluons/Photons (ROU-LOU, ROR-LOL) One symmetrical Gluon Photon (UOU).

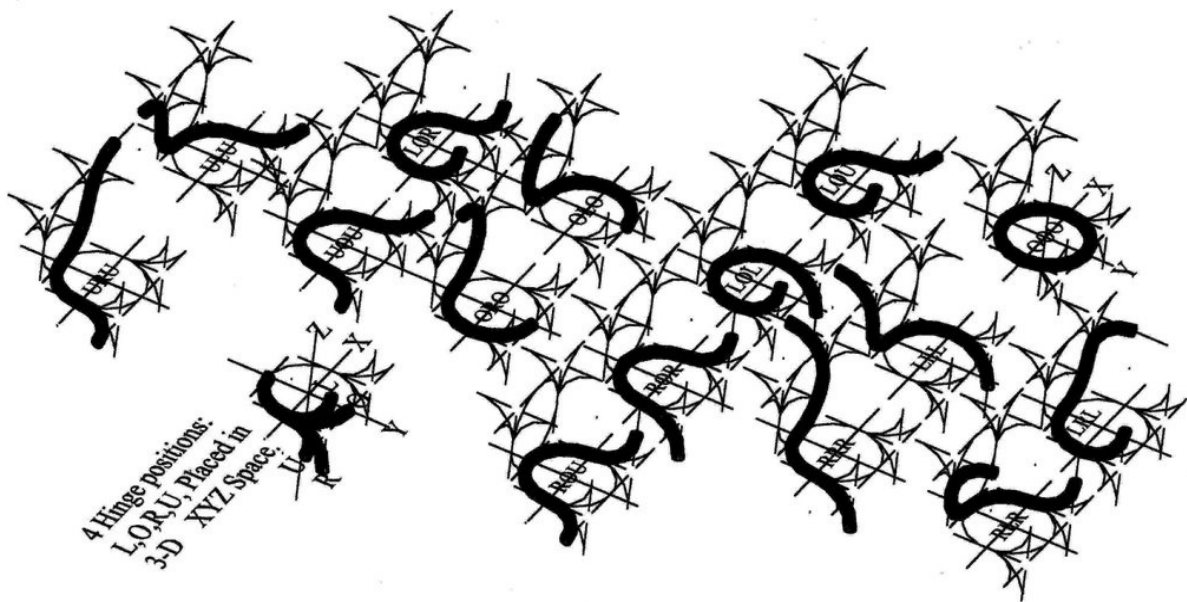

Figure 2, 3D image of all Singular particles including 3 sets of mirror symmetrical Neutrinos: RLR-LRL, RRR-LLL, URU-ULU.



Figure 3, 3D image of the Leptons: Electron, Positron, (singular) Muons and Tau particles (Compound particles).



Figure 4, 3D-Image of all 36 Quarks: UP-DOWN-STRANGE-CHARM-BOTTOM-TOP.

Geometry of the GOD particle based on four ELBOW MACARONI shaped arms connected with three hinges. These hinges are only able to rotate in steps of 90 degree rotation, coded with: O, L, R, and U relative rotations.

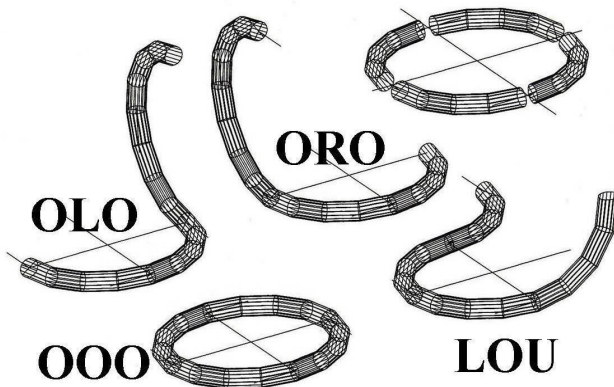

Figure 5.

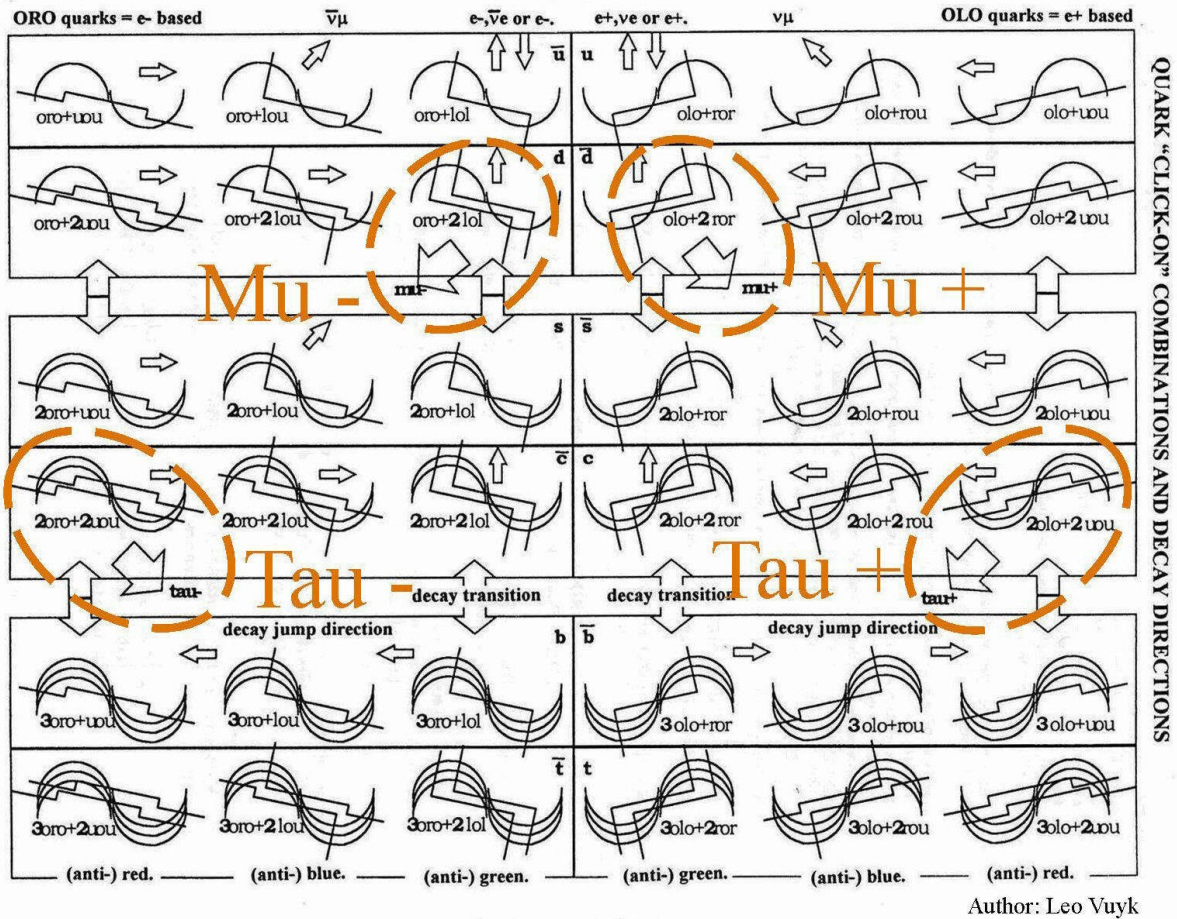

Figure 6, Simplified 2D image of Leptons and Quarks including indications for Decay routes indicated by arrows.

The Weak force, how change a d-quark (ORO+LLL+LRL) into an u-quark (OLO+ROR) in the case of Neutron-- Proton decay.

semi-leptonic processes

$$n \Rightarrow p + e^- + \bar{\nu}_e$$

$$ddu \Rightarrow duu + e^- + \bar{\nu}_e$$

The principle interaction is :

$$d \Rightarrow u + e^- + \bar{\nu}_e$$

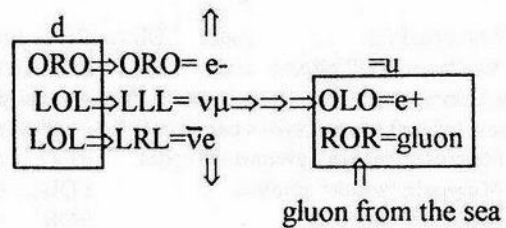

Figure 7, The WEAK force in action by a complex exchange of particles and without a clear sign of the Weak particle. Conclusion there is no need for a massive Weak particle in this system. The massless Higgs particle, seems to do the job properly by transformation of two compound Gluon particles (LOL) attached to the electron (ORO): (LOL into LLL) and (LOL into LRL) . In succession, the (LLL) particle is changed into (OLO) a Positron, able to combine with a free Gluon (ROR) out of the SEA of Gluon plasma.

THE DECAY OF QUARKS AND LEPTONS

According to my model: elementary particles have a **sub-quantum structure**, caused by the postulate that a kind of Higgs particle is the **basic elementary particle**. (see the relation with the model page: 4)

Two Higgs particles can change form by collision into an electron and positron pair. (ORO+OLO)

Each Higgs particle can change form by collision with a quark or lepton into one of the **6 different possible types of photons:**

- 1: **The graviton** code: LOR (or ROL) can not "click-on" to e+ or e- particles to form quarks.
 - 2: **The "general" photon** code UOU. can "click-on" to e+ or e- particles, to form quarks for all "red, anti-red" (the colors are my own choice) quarks. The general photon has no quark confinement function, so is not a "real" gluon. **The 4 (gluon) photon types can also "click-on" to e+ or e- they are:**
 - 3: **Magnetic "north" photon** (in code) ROU. combining for all "positive/blue, anti-blue" quarks.
 - 4: **Magnetic "south" photon** LOU. combining for all "negative/blue, anti-blue" quarks
 - 5: **Electric + photon** ROR. combining for all "positive/green, anti-green" quarks.
 - 6: **Electric - photon** LOL. combining for all "negative/green, anti-green" quarks.
- Quarks** are "click-on" combinations of e- and e+s with 5 different types of photons: 4 gluon types and 1 general type. (so: quarks are not elementary)

Together with 1,2 or 3 electrons, 3 photon types can "click on" and combine into different **negative charged quarks**.

The **electron**: ORO can combine with LOL, LOU (gluons) and UOU (general photon)

Together with 1,2 or 3 positrons, 3 photon types can "click on" and combine into different **positive charged quarks**.

The **positron**: OLO can combine with ROR, ROU (gluons) and UOU (general photon)

Higgs boson (in code) OOO

The H-bosons is responsible for:

A: all .photon/gluon production, as continuous collision product with all masscarrying particles.

(OOO+lepton/quark= photon/gluon+lepton/quark

B: spontaneous pair production (OOO+OOO=ORO+ OLO (e- and e+)),

Z	=ORO+OLO	Z-boson (electron + positron can "click" together, without annihilating each other)
Wo, W+ and W-		don't exist as particles.
e-	=ORO	electron.
e+	=OLO	positron.
νe	=RLR	electr. Neutrino.
$\bar{\nu}_e$	=LRL	anti-electr. Neutrino.
νμ	=LLL	muonic neutrino.
$\bar{\nu}_\mu$	=RRR	anti- muonic neutrino.
ντ	=ULU	tau neutrino
$\bar{\nu}_\tau$	=URU	anti- tau neutrino

For quark click-on combinations: see page 25 (over).

Quark "up-grading" due to subjoining of extra ORO's (or OLO's) (energy addition) and extra gluons, joining from the "sea" of gluons (energy addition)

$$\begin{aligned} & e^- \rightarrow \bar{u} \rightarrow d \rightarrow s \rightarrow \bar{c} \rightarrow b \rightarrow \bar{t} \\ \rightarrow & \text{ORO} \rightarrow 1 \text{ORO} \rightarrow 1 \text{ORO} \rightarrow 2 \text{ORO} \rightarrow 2 \text{ORO} \rightarrow 3 \text{ORO} \rightarrow 3 \text{ORO}. \\ & \quad 1 \text{gluon} \rightarrow 2 \text{gluon} \rightarrow 1 \text{gluon} \rightarrow 2 \text{gluon} \rightarrow 1 \text{gluon} \rightarrow 2 \text{gluon}. \end{aligned}$$

$$\begin{aligned} & e^+ \rightarrow u \rightarrow \bar{d} \rightarrow \bar{s} \rightarrow c \rightarrow \bar{b} \rightarrow t \\ \rightarrow & \text{OLO} \rightarrow 1 \text{OLO} \rightarrow 1 \text{OLO} \rightarrow 2 \text{OLO} \rightarrow 2 \text{OLO} \rightarrow 3 \text{OLO} \rightarrow 3 \text{OLO}. \\ & \quad 1 \text{gluon} \rightarrow 2 \text{gluon} \rightarrow 1 \text{gluon} \rightarrow 2 \text{gluon} \rightarrow 1 \text{gluon} \rightarrow 2 \text{gluon}. \end{aligned}$$

The **muon** is equivalent with the **naked (anti) green d(own)-quark**

The **tau** is equivalent with the **naked (anti) red b(ottom)-quark**

The differences between:

e- and \bar{u} , is one gluon,
 \bar{u} and d, is one gluon,
d and s, is one gluon changed form into an e-
s and \bar{c} , is one gluon,
 \bar{c} and b, is one gluon changed form into an e-
b and \bar{t} , is one gluon.

Quark "down-grading or decay" is going down the energy ladder, "spitting out" e-, e+'s and gluons in their original form (unchanged) or changed into neutrino's.

Quark stability is originated by the sub-quantum structure of the quark
If the structure has

1: an A-symmetric form (such as the (anti-)blue u-,s- and b-quarks), the ability to spin, and the stability is minor to those with a symmetric form.

2: more components, this will lead to:decrease of stability and mass increase due to more protuberances (more vulnerability for Higgs impulses) resp. more production of gravitons)

Lifetimes and decay routes of quarks should be dependant of these rules, but we see interesting changes:

The preferred (anti-) red-blue- green sequences of the decay ladders are changing between the charm and the bottom quarks.

The differences in the sequences of charges related to the mass ladder is not clear. Further investigation is needed.

Systematic summary of basic quark decay modes.

e- and e+ \Rightarrow UOU = general photon (annihilation)

$\bar{u} \Rightarrow e-, \bar{\nu}_e$	$\left \begin{array}{l} \text{ORO} \Rightarrow \text{ORO} = e- \\ \text{LOL} \Rightarrow \text{LRL} = \bar{\nu}_e \end{array} \right.$	$u \Rightarrow e+, \nu_e$	$\left \begin{array}{l} \text{OLO} \Rightarrow \text{OLO} = e+ \\ \text{ROR} \Rightarrow \text{RLR} = \nu_e \end{array} \right.$
---------------------------------------	---	---------------------------	---

$\bar{u} \Rightarrow e-$	$\left \begin{array}{l} \text{ORO} \Rightarrow \text{ORO} = e- \\ \text{LOL} \Rightarrow \text{gluon sea} \end{array} \right.$	$u \Rightarrow e+$	$\left \begin{array}{l} \text{OLO} \Rightarrow \text{OLO} = e+ \\ \text{ROR} \Rightarrow \text{gluon sea} \end{array} \right.$
--------------------------	---	--------------------	---

$\bar{u} \Rightarrow \bar{\nu}_\mu$	$\left \begin{array}{l} \text{ORO} \Rightarrow \text{RRR} = \bar{\nu}_\mu \\ \text{LOL} \Rightarrow \text{gluon sea} \end{array} \right.$	$u \Rightarrow \nu_\mu$	$\left \begin{array}{l} \text{OLO} \Rightarrow \text{LLL} = \nu_\mu \\ \text{ROR} \Rightarrow \text{gluon sea} \end{array} \right.$
-------------------------------------	--	-------------------------	--

(d (anti-)green is also: μ)

$d \Rightarrow e-, \bar{\nu}_e, \nu_\mu$	$\left \begin{array}{l} \text{ORO} \Rightarrow \text{ORO} = e- \\ \text{LOL} \Rightarrow \text{LRL} = \bar{\nu}_e \\ \text{LOL} \Rightarrow \text{LLL} = \nu_\mu \end{array} \right.$	$\bar{d} \Rightarrow e+, \nu_e, \bar{\nu}_\mu$	$\left \begin{array}{l} \text{OLO} \Rightarrow \text{OLO} = e+ \\ \text{ROR} \Rightarrow \text{RLR} = \nu_e \\ \text{ROR} \Rightarrow \text{RRR} = \bar{\nu}_\mu \end{array} \right.$
--	--	--	--

$\pi^- \Rightarrow \mu-, \nu_\mu$	$d = \mu-$	$\pi^+ \Rightarrow \mu+, \nu_\mu$	$\bar{d} = \mu$
$d\bar{u}$	$\bar{u} \left \begin{array}{l} \text{ORO} \Rightarrow \text{RRR} = \bar{\nu}_\mu \\ \text{LOL} \Rightarrow \text{gluon sea} \end{array} \right.$	du	$u \left \begin{array}{l} \text{OLO} \Rightarrow \text{LLL} = \nu_\mu \\ \text{ROR} \Rightarrow \text{gluon sea} \end{array} \right.$

$K^- \Rightarrow \mu-, \nu_\mu$	$\bar{u} \left \begin{array}{l} \text{ORO} \Rightarrow \text{RRR} = \bar{\nu}_\mu \\ \text{LOL} \Rightarrow \text{gluon sea} \end{array} \right.$	$K^+ \Rightarrow \mu+, \nu_\mu$	$u \left \begin{array}{l} \text{OLO} \Rightarrow \text{LLL} = \nu_\mu \\ \text{ROR} \Rightarrow \text{gluon sea} \end{array} \right.$
$s\bar{u}$		$\bar{s}u$	

$s = \left \begin{array}{l} \text{ORO} \Rightarrow \text{ORO} \\ \text{ORO} \Rightarrow \text{LOL} \\ \text{LOL} \Rightarrow \text{LOL} \end{array} \right = \mu^-$	$\bar{s} = \left \begin{array}{l} \text{OLO} \Rightarrow \text{OLO} \\ \text{OLO} \Rightarrow \text{ROR} \\ \text{ROR} \Rightarrow \text{ROR} \end{array} \right = \mu^+$
---	---

Three different kinds of Weak interactions.

Hydronic decays:

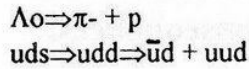

The principle interaction is:

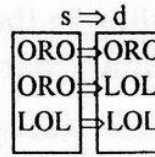

$s \Rightarrow d$ and pair production (addition) of u and \bar{u} from the Higgs and gluon "sea"

semi-leptonic processes

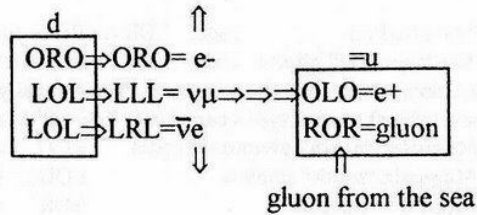
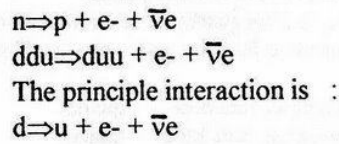

leptonic processes

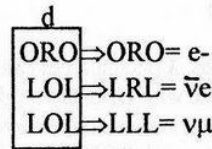
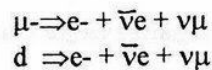

Some electromagnetic decays.

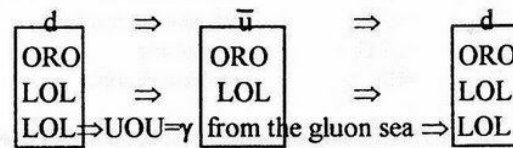
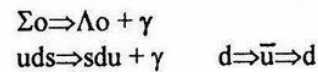
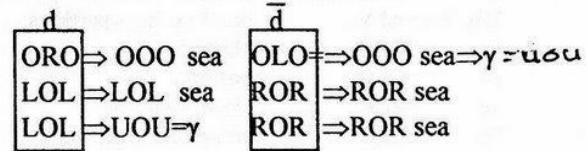
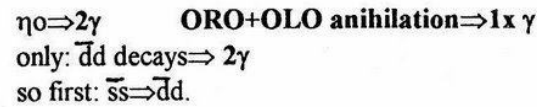
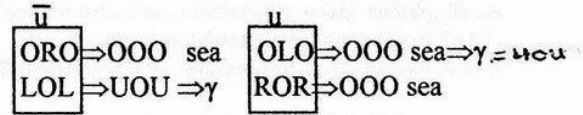
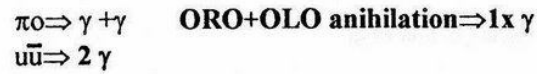

Some strong interactions.

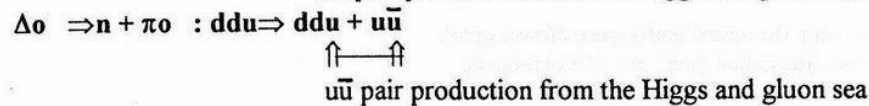
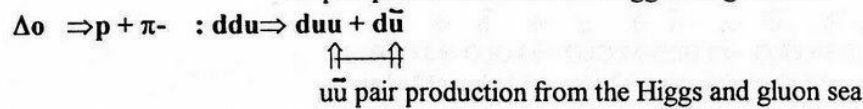
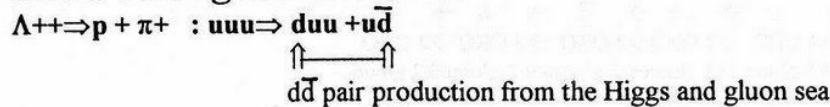

The double spin of Fermions.

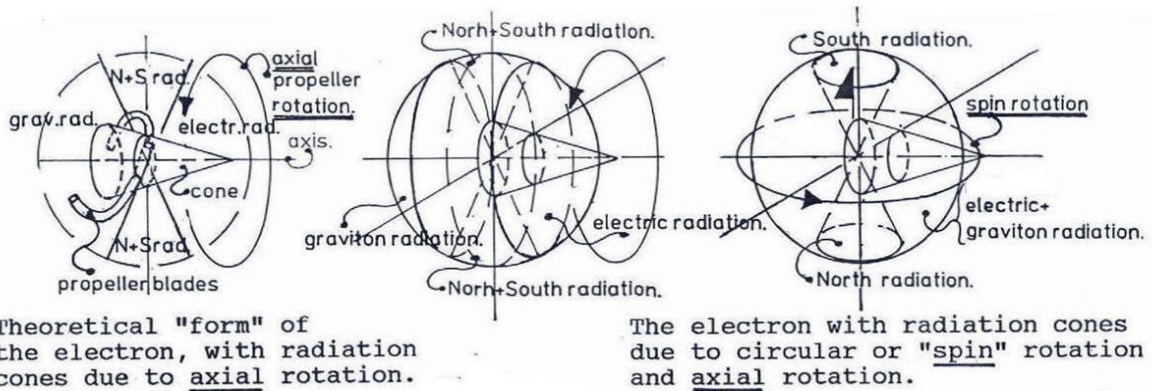

The "Eigen energy" distribution around the spinning Fermion propeller, is supposed to come in cone form. The Fermion spin and radiation is the product of a scattering process with oscillating Higgs vacuum particles. As a result, the Fermion has a double spin around two polar axes. This is supposed to be the origin of a dipole Magnetic field with North and South monopole photon radiation and the circular distribution of graviton and electric radiation. In addition it must be stated that all Fermions are entangled with their object /subject particle far away.

Figure 8, double spin of Fermion and Quark propellers.

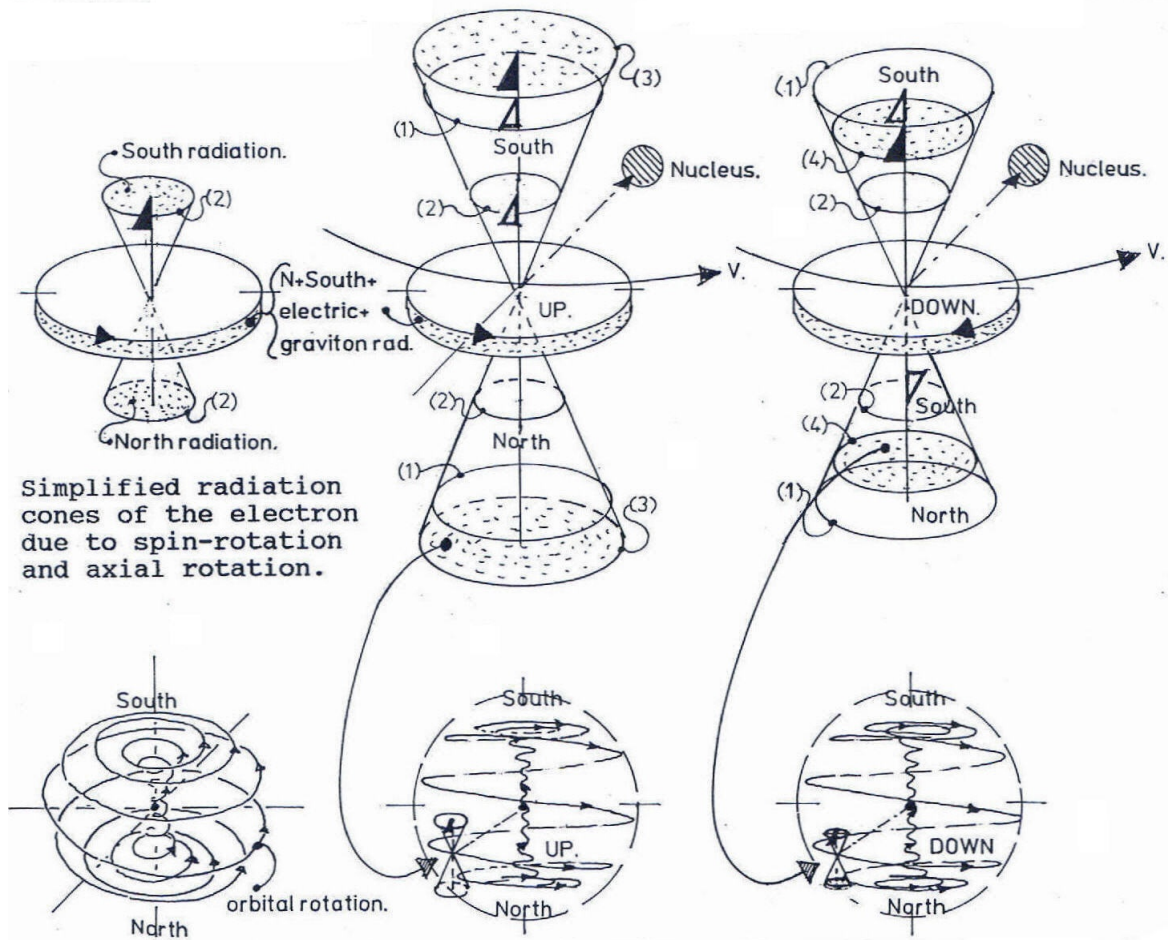

Figure 9, The difference between up and down Atoms.

Additional suggestion for the W^+ and Z particles.

The W particles could harbour one or two extra valence Electrons or Positrons to explain the recent so called Tevatron Bump at about 145 GeV, inside Fermilab's Tevatron collider.

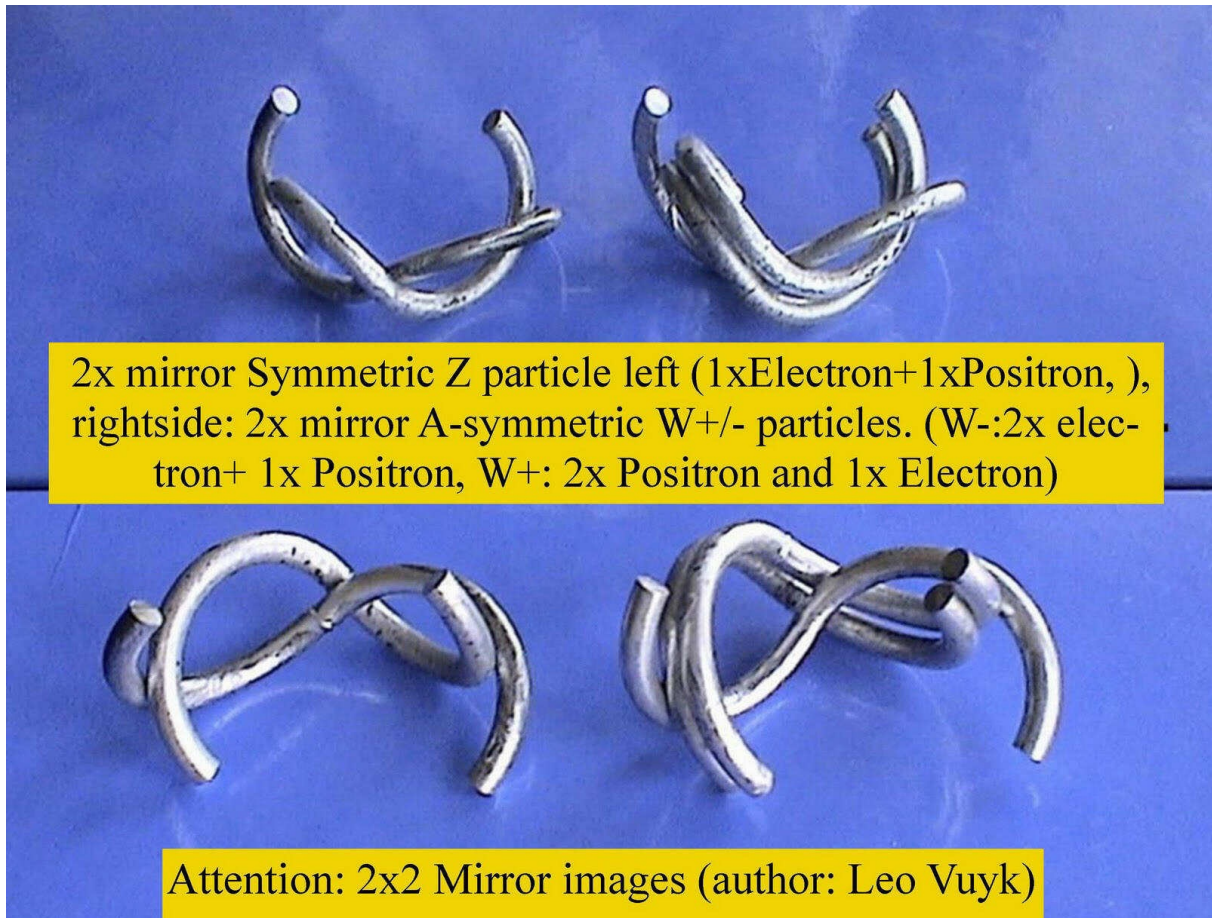

Figure 10 ,

As we are able observe below in the Q-FFF model images, there is geometrical room for additional Gluons to the Top Quark of the 36 standard models to create a heavier Top Quark. Even additional electrons or positrons could be the origin of additional so called TOP Prime Quarks recently found at the Tevatron.

Quantum Function Follows Form Model

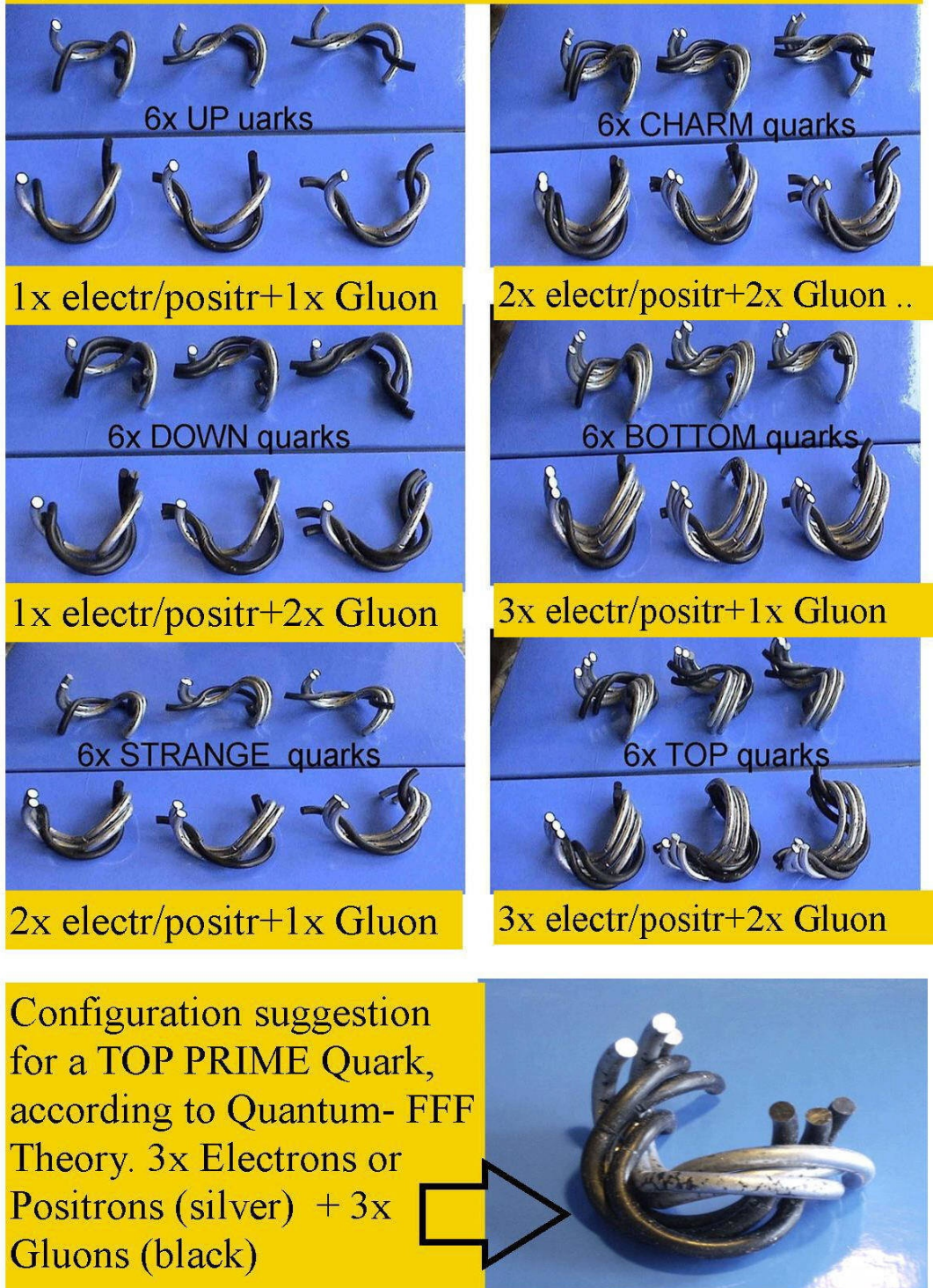

Figure 11,

The Higgs Torus (Macaroni shaped) particle.

The Higgs Torus particle is designed as a real 3D Shape-changeable Particle, to model and mimic the sub-quantum structure of all known Particles described by the “standard model” and beyond the standard model, (monopoles, Gluons) to be able to explain even the most complex and weird particle decay processes like the Kaon decay. (See below and the Attached pages 1-6)

Only spinning particles gain mass by the production of gravitons out of the collision process with massless Higgs particles

Decay examples:

Muon decay.

The Muon decaying compound “click-on” Particle (see Below) coded: (ORO,LOL,LOL). Is able to decay into three single parts: ORO+LRL+LLL. (changing one LOL into a LRL Particle (one hinge rotation over 90 degrees: R>L) and one LOL into a LLL Particle (one hinge rotation over 90 degrees: O>L).

These particles are called: the Electron(ORO), the anti-electro-neutrino (LRL) and the muonic neutrino (LLL).

Kaon decay.For normal Kaon plus decay, the main decay routes according to the literature are: (A: mu+, muonic neutrino)or (B: pi+, pi0)

The Kaon + Particle is coded: for the U-Quark:(OLO,ROR)and for the anti-S Quark: (OLO,OLO,ROR).

For the A route: it is proposed that the u-Quark (OLO,ROR)decays into (LLL,ROR) which Particle is supposed to disintegrate and produce the (LLL) muonic neutrino and one undetected Gluon (ROR) will disappear into the Gluonic “sea”.

The anti-s-Quark (OLO,OLO,ROR)will change into a positive muon (OLO,ROR,ROR).

For the B route: it is proposed that the U-Quark (OLO,ROR) does not decay and that the anti-S Quark also decays into (OLO,ROR,ROR) which is in combination with the U-Quark a positive pion+ Particle.

The pion-0 Particle coded: U, anti-U Quark: (OLO,ROR), and (ORO,LOL) are mirror symmetric and able to emerge directly from the vacuum as so called pair production results.

Rare Kaon–Plus decay.

A rare Kaon plus Particle decay: $K^+ \Rightarrow \pi^+, \nu, \bar{\nu}$, (pi + , neutrino anti-neutrino) is recently

discovered and now acknowledged by a Brookhaven AGS experiment 949:see: <http://www.phy.bnl.gov/949/>

Interestingly this rare Kaon decay can easily be derived from the “Higgs Torus Particle” system properties.

The most simple explanation by this Higgs Particle click-on system is to assume that the decay is the same as route B mentioned before and in addition that the Pion 0 Particle (OLO,ROR)+(ORO,LOL) decays into two neutrinos.(OLO) \Rightarrow (RLR) and (ORO) \Rightarrow (LRL). The (ROR) and (LOL) Gluons are supposed to “disappear into the Gluonic “sea” as described above under route A.

Kaon Long/ Short decay.

It is proposed that the Kaon and anti Kaon Particles (ds)are mixing with themselves and with the Eta (ss) Particle by the continuous changing of one Gluon into a Lepton to change the d Quark into an s Quark and backwards a Lepton into a Gluon from s into a Quark. (d \Leftrightarrow s)

At the same time it is proposed that the backward changing d into s last longer due to the slight chirality of the vacuum .

The angle of attack of the Tandem oscillating Higgs Particles to the Quarks, must be slightly different.

This is reason to propose that it is the S, anti-S (Eta Particle) that is the reason for the strange Kaon decay time-differences

Explanation: the Kaon 0 Particle coded as: d-Quark: (ORO,LOL,LOL) anti-s Quark: (OLO,OLO,ROR) will change into an Eta (s) Particle: s Quark: (ORO,ORO,LOL) anti-s Quark: (OLO, OLO, ROR) by the Direct Weak attack mechanism of the tandem vacuum Particles to change three hinges of one compound Particle at once (OLO \Leftrightarrow ROR, or ORO \Leftrightarrow LOL).

Then after a while, the intermediate (s anti-s) Eta Particle will be changed into the anti-Kano-0, coded: S: (ORO,ORO,LOL) anti-D: (OLO,ROR,ROR,)

Thus it is assumed that the origin of this strange Long and Short Kaon decay mechanism is to find in the difference in transition speed for the LOL Gluon into the ORO Electron (needed to change the d Quark into an s Quark) which is supposed to be faster due to the chirality of the vacuum than the transition speed to change the OLO Positron into the ROR Gluon (needed to change the anti-s Quark into an anti d Quark, to produce the anti Kaon-0 Particle).

Special Weak Interactions:

The "Direct Weak attack mechanism by the tandem oscillating vacuum Particles" or "two Higgs doublets".

Special Weak interactions are supposed to change all three Hinges at once without the aid of the Z-Particle, such as in Kaon 0,- Eta mixing processes (OLO \Leftrightarrow ROR or ORO \Leftrightarrow LOL described below).

Glueballs.

(for latest Glueball information see also;
http://arxiv.org/PS_cache/hep-ph/pdf/0209/0209339.pdf)

The shape of some Gluons makes it possible to suggest that these Particles are able to "click-on" to each other WITHOUT THE AID OF ELECTRON or POSITRONS and form so called Glueballs, found already 20 years ago in collider experiments.

Model experiments are pointing into the direction of 10x "bound state, click-on" possibilities for two Gluon Glueballs and also 8x Exotic "bound state, click-on" possibilities of Gluons with single Leptons (ORO and OLO).

10 different Knots with 2xGluon Bound States:

UOU+ROR, UOU+LOL.
UOU+LOU, UOU+ROU.

LOU+ROU 2x because there is also a second mirror image possible.

ROR+LOU, ROR+ROU.
LOL+LOU, LOL+ROU.

8x different Exotic Knots with Gluon-Lepton Bound States.

OLO+LOU, OLO+ROU.
OLO+LOL, OLO+UOU.

ORO+LOU, ORO+ROU,
ORO+ROR, ORO+UOU.

For comparison, see: 17 masses at
http://arxiv.org/PS_cache/hep-ph/pdf/0209/0209339.pdf
Page 11 figure 1, comparison between the Glueball spectrum and Knot energies.

By: R. Buney.

2x different Knots with 3x Gluon bound states:

3x ROU or 3x LOU.

1x Knot with 4x Gluon bound states:

4x UOU.

This new description of elementary Particles, is based on the idea that Quarks are not single Particles but compound Particles (bound states) and able to be created out of the Higgs vacuum at once as Particle anti-Particle (Quark) pairs, just like an Electron Positron pair and able to decay into smaller parts. (see Page 1)

Kitchen Table Models.

Based on real “kitchen table” model binding experiments, it is proposed that the 36 different Quarks of the “Standard model” are composed out of one, two or three Electrons, or Positrons and one or two Gluons, both kept together inside the Quark, by the special shape which these Higgs Particles should have. All these forms are supposed to be derived by real shape transformation out of only one Particle, called the “Higgs” Particle which should have a special Torus form.

The Torus form is supposed to be equally divided into FOUR rigid quarter parts, (like “Macaroni” tubes) each able to rotate axial relative to the neighbouring Macaroni tubes and change the shape of the original Higgs Torus into more complex shapes.

It is assumed that the unification of Particles is based on a simple 90 degree axial “cutting-edge rotation” of the four quarters of the Higgs Torus form.

This Toy system seems to be surprisingly a simple aid to mimic shapes for elementary Particles, exotic Particles like Glueballs and sub-quantum decay processes.

Higgs (macaroni) Particle model description.

If we imagine a rubber Torus shaped Sealing Ring (say about 4 cm diameter and a thickness to ring diameter ratio of about 1: 7) which we cut in two halves, then we are able to make simple propeller forms out of it, with two different so called “Pitches”.

We are able to make propeller forms with a left handed Pitch, or with a right handed Pitch.

We can do so, by gluing the two halves together again after rotation of one half of the Torus over 90 degrees (left or right rotated), at one of the two cutting edges. (see page 2, 4,5 and 6)

At the same time, for more complex Particles we need

to cut the Torus into 4 equal quarters (macaroni parts), connected to each other by so called “Hinges”, which are proposed to be able to rotate axial in steps of 90 degrees.

For each Particle , there has to be only three Hinges which are coded by the mutual rotational displacement possibilities: O(=unchanged circle) ,U (=180 degree rotation), L (=90 degree Left hand rotation) and R (=90 degree Right hand rotation).

As a consequence, the most simple Particle shapes are the two “Pitched Propeller forms” described before, coded ORO and OLO., which we will call arbitrarily the Electron respectively the Positron.

As an other consequence, the Particle with three unchanged hinges is coded: (OOO), which is chosen to be the Higgs-Particle.

A Particle with all three hinges with 90 degrees rotation to the Right relative to the neighbouring quarter part, is called (RRR) for three hinges with 90 degrees rotation left it is coded: (LLL) .

The Particle with three hinges rotated over 180 degrees is coded: (UUU).

However not all possible shapes are needed to mimic the standard model, so Particles with a middle hinge coded U : (XUX) are not used. The only Particles with U coded hinges are: UOU ULU URU LOU and ROU. (UOR and UOL are the same Particles as respectively ROU and LOU.)

Mechanistic particle transformation.

THE RING SHAPED Higgs Particles coded(OOO) are supposed to oscillate in Tandem along so called linear Vacuum Lattices, two by two in opposite directions, as the symmetrical opposite pistons of a boxer engine, as the origin of all energy, spin and mass effects.

This enables the Tandem Higgs Particles (doublets) to change the form of their own Torus into an Electron and Positron pair at the same time and to originate all other oscillations and interactions, as $d \leftrightarrow s$ and $c \leftrightarrow b$.

It is proposed that Photon radiation is the result of mechanical change by collisions between Single Higgs Particles and Quarks or Leptons.

There are 6 different shapes for Photons and 5 of them are supposed to act also as Gluons, because they are able to “click –on” to a Positron or Electron and form Quarks, Muons or Tau Particles.

Weak interaction: The two-Higgs doublets in collision with the Quark connected Gluons, are supposed to be able to change the symmetrical shape of three sorts of Gluons (UOU,ROR and LOL) into Neutrinos, respectively URU,ULU,RRR,RLR,LRL,LLL).

Z-Particles are so called Positroniums (compound Electron and Positron) able to catch neutrinos and form a compound temporary W Particle, which seem to be needed to be able to reshape the Neutrino into a Positron or Electron or even backwards.

As an example, in Neutron decay, the LOL (d-Quark: ORO+LOL+LOL) Gluon changes via a Muonic Neutrino LLL into a Positron OLO (u-Quark: OLO+ROR).(see page 3)

With this Higgs system, it is supposed that Higgs Particles are able to transfer Photonic geometrical information at a linear average speed of 7/4 the speed of Light. The expected transfer retardation at the vortexes of the Chiral Tetrahedron vacuum Lattice is included. This should enable the vacuum to mimic the isotropy of the speed of light.

See: <http://home.planet.nl/~vuyk0022/> see: “the Local Anti-Symmetrical Oscillating vacuum Frame” (LASOF)

Summary of the single shaped Particles.

The two simple propeller shaped Particles are coded:

ORO: the Electron.

OLO: the Positron.

Gluons.

There are in contrast with the standard model only 5 Gluons needed to satisfy the standard model colour differences of Quarks.

The Gluons are all 5 able to “click on to the Electron or Positron and form a compound Particles needed for all Quarks the Muon and Tau Particle .

They are coded:

UOU, ROR, LOL, LOU, ROU.

Photons.

There are in contrast with the standard model : 6 different shapes for (Monopole) Photons, 5 of them have the same shape as the Gluons mentioned before, they are: .

UOU= Photon for visible and IR light.

ROR= electric + Photon

LOL= electric – Photon

LOU= magnetic South Photon

ROU= magnetic North Photon

.....
The Graviton ROL (or LOR)= is expected to be the Photon without “click-on” possibilities.

Because of the frequency overlap of gamma and x-ray radiation it could be possible that this radiation is not based on the so called General Photon UOU, but should be coded differently as LOO and ROO.

In that case there are 8 Photons in stead of 6.

Neutrinos.

Neutrinos are supposed to be NOT able to “click-on” with compound fermions as Gluons do.

In contrast Neutrinos are supposed to be originated as collision products out of the shape of one of the 5 Gluons or Electron or Positron by the standard Weak Z-Particle operation

Neutrinos with codes and origin Particles:

RRR: the anti-muon-neutrino. Possible origin

Particles: ROR, ORO

LLL: the muon-neutrino. LOL, OLO

RLR: the electro-neutrino. ROR, OLO

LRL: the anti-electro-neutrino. LOL, ORO

URU: the Tau-neutrino. UOU.

ULU: the anti-Tau-neutrino. UOU.

The Z-Particle.

The Z-Particle is supposed to be a very loose “click-on” compound combination of an Electron (ORO) and a Positron (OLO).

The W-Particle is not assumed to exist as a single Particle, it is assumed to be a Particle changing process, in combination with the “aiding” Z-Particle.

The Z Particle is supposed to be a help by form changing processes of Standard Weak interactions (described above).

Quark generations.

The three different coloured Up-Quarks are coded:

ORO+LOL, or ORO+LOU, or ORO+UOU. (2 compound Particles)

Anti-Up-Quarks (three colours) are coded:

OLO+ROR, or OLO+ROU, or OLO+UOU. (2 compound Particles)

Down-Quarks (three colours) are coded:

ORO+2.LOL, or ORO+2.LOU, or ORO+2.UOU. (3 compound Particles)

anti-Down-Quarks (three colours) are coded:

OLO+2.ROR, or OLO+2.ROU, or OLO+2.UOU. (3 compound Particles)

The three different coloured Strange-Quarks are coded:

2.ORO+LOL, 2.ORO+LOU, or 2.ORO+UOU. (3 compound Particles)

Anti-Strange-Quarks (three colours) are coded:
2. OLO+ROR, 2.OLO+ROU, or 2.OLO+UOU. (3 compound
Particles)

Charm-Quarks (three colours) are coded:
2.ORO+2.LOL, 2.ORO+2.LOU, or 2.ORO+2.UOU. (4 compound
Particles)

anti-Charm-Quarks (three colours) are coded:
2.OLO+2.ROR, 2.OLO+2.ROU, or 2.OLO+2.UOU. (4 compound
Particles)

The three different coloured Bottom-Quarks are coded:

3.ORO+LOL, 3.ORO+LOU, or 3.ORO+UOU. (4 compound
Particles)

Anti-Bottom-Quarks (three colours) are coded:
3. OLO+ROR, 3.OLO+ROU, or 3.OLO+UOU. (4 compound
Particles)

Top-Quarks (three colours) are coded:
3.ORO+2.LOL, 3.ORO+2.LOU, or 3.ORO+2.UOU. (5 compound
Particles)

anti-Top-Quarks (three colours) are coded:
3.OLO+2.ROR, 3.OLO+2.ROU, or 3.OLO+2.UOU. (5 compound
Particles)

Compound Leptons: Muon Particles are coded: mu+: OLO+2ORO,
(=anti-d-Quark) mu-: ORO+2.LOL.(=d-Quark)
Tau Particles are coded: tau+: 2.OLO+2UOU, (=c-Quark).
tau-: 2ORO+2UOU.(=anti-c-Quark)

Counting Particles. I count: 6 Photons (Gluons included) , 6 single
neutrinos, 2 single leptons and one single
Higgs-Particle= 17 single Particles. +36 compound
Quarks and one compound Z Particle = 54 different
formed functional Particles if we exclude exotic
Particles like Glueballs etc.(see below)

MATTER CREATION AND THE CHIRAL VACUUM.

A new reason for a dual-symmetrical smooth evaporation
of multiple anti-mirror universes in an alternative
Big Bang process, is based on the new system for
elementary Particles, described before and the
chirality of the Higgs-Particle based vacuum .
The chirality of the vacuum , should be responsible,
for our material universe, because it is assumed that

anti-matter is less stable than matter within the moment of creation in a chiral oscillating vacuum after the “semi-cold Higgs particles evaporating Big Bang”.

Thus Matter in our universe, is supposed to be created without annihilation processes, direct out of the evaporated vacuum Higgs-Particles.

At a result, the chirality of the vacuum should be responsible for the origin of strange CP violations found in the so called Kaon- O Short and Long decay.

References:

[1] [viXra:1102.0052](#) 27 Feb 2011

Construction Principles for Chiral "atoms of Spacetime Geometry".

Authors: Leo Vuyk

Category: [Quantum Physics](#)

[2] [viXra:1102.0054](#) 27 Feb 2011

Atomic Nuclear Geometry Based on Magic Number Logic.

Authors: Leo Vuyk.

Category: [Nuclear and Atomic Physics](#)

[3] [viXra:1102.0056](#) 28 Feb 2011

Experiments to Determine the Mass Related Lightspeed Extinction Volume Around the Earth and Around Spinning Objects in the Lab.

Authors: Leo Vuyk.

Category: [Relativity and Cosmology](#)

[4] The New God Particle and Free Will.

By Leo Vuyk, LuLu publishers, 2008.

ISBN number 978-1-4092-1031-3