

ABSTRACT

Prime Sieve Using Multiplication Operation Table

Jong-Soo Park

Department of Computer Science and Engineering
Chungnam National University
Daejeon, Korea

(Supervised by Professor Cheong Youn)

Ben Green and Terence Tao showed that for any positive integer k , there exist infinitely many arithmetic progressions of length k consisting only of prime numbers. [14] Four parallel proofs of Szemerédi's theorem have been achieved; one by direct combinatorics, one by ergodic theory, one by hypergraph theory, and one by Fourier analysis and additive combinatorics. Even with so many proofs, Professor T. Tao points out that with this problem, there remains a sense that our understanding of this result is incomplete; for instance, none of the approaches were powerful enough to detect progressions in the primes, mainly due to the sparsity of the prime sequence. [22] Oliver Lonsdale Atkin introduced a prime sieve using irreducible binary quadratic forms and modular arithmetic; the algorithm enumerates representations of integers by certain binary quadratic forms. A way that uses modular arithmetic is widely known: $6n + \delta$, $12n + \delta$, $30n + \delta$, $60n + \delta$. [31] In this paper, we assert that the composite number of the $12n + 1, 5, 7, 11$ series as selected by a Modular Arithmetic and Multiplication Table are not random but consist of very structural and regular arithmetic progression groups.

Table of contents

1. Introduction	
1.1. Primes in Modular Arithmetic.....	1
1.2. Primes in Arithmetic Progression.....	2
2. The Specific Composite Numbers of the $12n+1,5,7,11$ series	
2.1 Generating the Composite Number of the $12n+1,5,7,11$ series.....	2
2.2 Prime Sieve.....	6
2.3 The Structure of a matrix-multiplication of $A_n \times A_n$	7
2.4 Symmetric table and Asymmetric table.....	8
<i>i) Symmetric table, $\alpha = \beta$</i>	
<i>ii) Asymmetric table, $\alpha \neq \beta$</i>	
3. Composites in Arithmetic Progression.....	10
4. Primality Test	
4.1 Substitution.....	30
4.2 Determination of a valid domain.....	31
4.3 Finding integer values of x and y	34
4.3.1 First Method- Pell's equation	35
4.3.2 Second Method-n-k curve	37
5. Uncertainty Principle	39
6. Impossibility Principle	40
7. Conclusion	41
8. Reference	42
<Appendix 1> Certainty of Mathematics	45
<Appendix 2> Discovery of Number	51
<Appendix 3> Duality(Prime Number Theorem)	55
<Appendix 4> Addition of Primes(Goldbach's conjecture).....	63
<Appendix 5> Seeking Truth	66
<Appendix 6> Attached document	71

1. Introduction

Look through a list of prime numbers and you'll find that it's impossible to predict when the next prime will appear. The list seems chaotic, random, and offers no clues as to how determine the next number. It is hard to guess at a formula that could generate this kind of pattern. In fact, this procession of primes resembles a random succession of numbers much more than it does a nice orderly pattern. [8] [21]

This paper starts from the question of "Can we express prime numbers and recognize them spatially such as Prime Spiral?" The prime spiral, also known as Ulam's spiral, is a plot in which the positive integers are arranged in a spiral, with primes indicated in some way along the spiral.

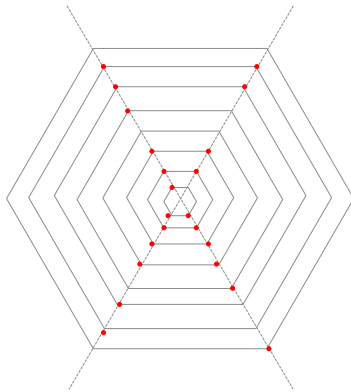

Figure – 1) Prime numbers are aligned to X-shape of 4 groups with a period of $12n$.(except 2, 3)

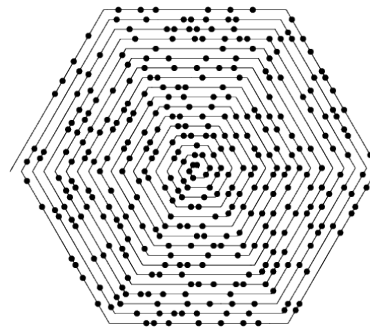

Figure – 2) A hexagonal prime spiral can also be constructed, as illustrated above (Abbott 2005, wolfram).

1.1. Primes in Modular Arithmetic

If a and d are integers, with d non-zero, then a remainder is an integer r such that $a = qd + r$ for some integer q , and with $0 \leq |r| < |d|$. [46] Putting prime numbers on the regular hexagon, every prime number except 2 and 3 is contained in the $12n+1, 5, 7, 11$ series, is sorted into 4 kinds of remainder groups—1, 5, 7, and 11—and belongs to at least one of these 4 groups.

1.2 Primes in Arithmetic Progression

Dirichlet's theorem, states that for any two positive coprime integers a and d , there are infinitely many primes of the form $a + nd$, where $n \geq 0$. In other words: there are infinitely many primes which are congruent to a modulo d . The numbers of the form $a + nd$ form

an arithmetic progression [37]

$$a, a + d, a + 2d, a + 3d, \dots a + nd$$

and Dirichlet's theorem states that this sequence contains infinitely many prime numbers.[33] Szemerédi's theorem generalizes the statement of van der Waerden's theorem. A theorem of Szemerédi asserts that all subsets of the integers with positive upper density will contain arbitrarily long arithmetic progressions. [22] Also any given arithmetic progression of primes has a finite length. Green-Tao settled an Szemerédi' conjecture by proving the Green-Tao theorem (The primes contain arbitrarily long arithmetic progressions). It follows immediately that there are infinitely many AP-k for any k (integer $k \geq 3$, an AP-k (also called PAP-k) is k primes in arithmetic progression) [23]

2. The Specific Composite Numbers of the $12n + 1, 5, 7, 11$ series

Like prime numbers, composite numbers appear intuitively irregular and seem to be difficult to group into a pattern. But, the specific composite numbers are generated by a certain rule and that rule is that composite numbers consist of sixteen arithmetic progression groups of different lengths; each group and each arithmetic progression included in that group forms that rule.

$$25 = 5 \times 5, 35 = 5 \times 7, 49 = 7 \times 7, 55 = 5 \times 11, 65 = 5 \times 13, 77 = 7 \times 11, \\ 85 = 5 \times 17, 91 = 7 \times 13, 95 = 5 \times 19, 115 = 5 \times 23, 119 = 7 \times 17$$

2.1 Generating the Composite Number of the $12n + 1, 5, 7, 11$ series

Let us denote the set A_n is all elements of the $12n + 1, 5, 7, 11$ series($n=0,1,2,\dots$); the set P_n is all elements of prime numbers as comprised in A_n ; the set C_n is all elements of composite numbers as comprised in A_n

1	2	3	4	5	6	7	8	9	10	11	12
13	14	15	16	17	18	19	20	21	22	23	24
25	26	27	28	29	30	31	32	33	34	35	36
37	38	39	40	41	42	43	44	45	46	47	48
49	50	51	52	53	54	55	56	57	58	59	60
61	62	63	64	65	66	67	68	69	70	71	72
73	74	75	76	77	78	79	80	81	82	83	84
85	86	87	88	89	90	91	92	93	94	95	96
⋮	⋮	⋮	⋮	⋮	⋮	⋮	⋮	⋮	⋮	⋮	⋮
$12n+1$	$12n+2$	$12n+3$	$12n+4$	$12n+5$	$12n+6$	$12n+7$	$12n+8$	$12n+9$	$12n+10$	$12n+11$	$12n+12$

Table – 1) All elements of the $12n+1,5,7,11$ series are not multiples of 2 and 3. Therefore, all prime numbers except 2 and 3 are contained in the $12n+1,5,7,11$ series. The number in the box denotes the elements of C_n .

Theorem 1.1) All prime numbers but 2 and 3 exist in forms of $12n+1,5,7,11$ with a period of $12n$.

Proof A)

(i) All natural numbers can be represented with a period of 12.

(ii) All even numbers but 2 are not prime numbers

Elements of $12n+2,4,6,8,10,12$ are all even. ($n=0,1,2,\dots,n$)

Therefore, all $12n+2,4,6,8,10,12$'s but 2 are not prime numbers.

(iii) All $12n+3$'s but 3 are not prime numbers.

$12n+3 = (3 \times 4)n + 3$ is a multiple of 3.

(iv) $12n+9$ is not a prime number.

$12n+9 = (3 \times 4)n + 9$ is a multiple of 3.

As in Theorem 1), every prime number but 2 and 3 is contained in the periodic A_n . So, let us denote this series as follows:

$$A_n = \begin{cases} A_1, & \text{if remainder} \equiv 1 \pmod{12} \\ A_5, & \text{if remainder} \equiv 5 \pmod{12} \\ A_7, & \text{if remainder} \equiv 7 \pmod{12} \\ A_{11}, & \text{if remainder} \equiv 11 \pmod{12} \end{cases}$$

In *Figure – 2) Figure – 3)*, the A_n series are multiplied infinitely and we can find 10 basics equations which falls into one of the 4 groups.

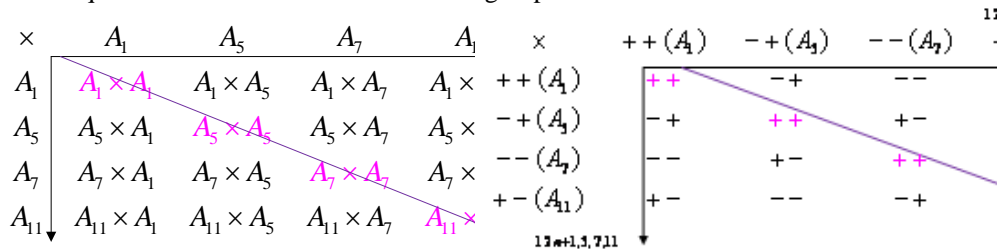

Figure – 3) Multiplication Table

Figure – 4) Sign Assignments in the Multiplication Table

If we assign signs, we can summarize them as follows:

Multiplication	Sign	Equation	Remainder
$A_1 \times A_1$	$++(A_1)$	$(12x + 1)(12y + 1)$	1 (mod 12)
$A_5 \times A_5$	$++(A_1)$	$(12x + 5)(12y + 5)$	1 (mod 12)
$A_7 \times A_7$	$++(A_1)$	$(12x + 7)(12y + 7)$	1 (mod 12)
$A_{11} \times A_{11}$	$++(A_1)$	$(12x + 11)(12y + 11)$	1 (mod 12)
$A_1 \times A_5$	$-(A_5)$	$(12x + 1)(12y + 5)$	5 (mod 12)
$A_7 \times A_{11}$	$-(A_5)$	$(12x + 7)(12y + 11)$	5 (mod 12)
$A_1 \times A_7$	$--(A_7)$	$(12x + 1)(12y + 7)$	7 (mod 12)
$A_5 \times A_{11}$	$--(A_7)$	$(12x + 5)(12y + 11)$	7 (mod 12)
$A_1 \times A_{11}$	$+- (A_{11})$	$(12x + 1)(12y + 11)$	11 (mod 12)
$A_5 \times A_7$	$+- (A_{11})$	$(12x + 5)(12y + 7)$	11 (mod 12)

Table – 2) The Result List of Multiplication Table

Theorem 1.2) All elements of the $A_n \times A_n$ table multiplication are contained in set A_n .

Proof B)

$$(12x + \alpha)(12y + \beta), (\alpha, \beta \in \{1, 5, 7, 11\}) =$$

$$144xy + 12\beta x + 12\alpha y + \alpha\beta = \begin{cases} \alpha\beta \in \{1, 25, 49, 121\}, & \text{if remainder} \equiv 1 \pmod{12} \\ \alpha\beta \in \{5, 77\}, & \text{if remainder} \equiv 5 \pmod{12} \\ \alpha\beta \in \{7, 55\}, & \text{if remainder} \equiv 7 \pmod{12} \\ \alpha\beta \in \{11, 35\}, & \text{if remainder} \equiv 11 \pmod{12} \end{cases}$$

Therefore, $\alpha\beta \in \{1, 5, 7, 11, 25, 35, 49, 55, 77, 121\}$

Theorem 1.3) All elements of the A_n table multiplication are contained in the set of the $A_n \times A_n$ table multiplication.

Proof C)

For any element k of the set A_n : $k \in P_n$ or $k \in C_n$,

$$\text{if } k \text{ is } \begin{cases} P_n : P_n \times 1, k \in (12x + \alpha) \times 1 \text{ or } 1 \times (12y + \beta) \\ C_n : \begin{cases} P_n \times P_n, k \in (12x + \alpha) \times (12y + \beta) \\ P_n \times C_n, k \in (12x + \alpha) \times (12y + \beta) \\ C_n \times C_n, k \in (12x + \alpha) \times (12y + \beta) \end{cases} \end{cases}$$

Therefore, $C_n \geq 25$. Additionally, it is possible to find all values of C_n of the $12n+1, 5, 7, 11$ series in the results of a matrix-multiplication of $A_n \times A_n$ that are greater than 5.

\times	5	7	11	13	17	19	$12x+1, 5, 7, 11(\text{except } 1)$		
							23	25	
5	25								
7	35	49							
11	55	77	121						
13	65	91	143	169					
17	85	119	187	221	289				
19	95	133	209	247	223	361			
23	115	161	253	299	391	437	529		
25	125	175	275	325	425	475	575	625	

Figure – 2) Multiplication Table of $12n + 1, 5, 7, 11$ series

2.2 Prime Sieve

In the third century B.C., the scholar Eratosthenes came up with a simple algorithm for listing all the prime numbers up to a given N , referred to as the sieve of Eratosthenes. A standard improvement in the sieve of Eratosthenes is to enumerate values of xy not divisible by 2, 3, or 5. [30]

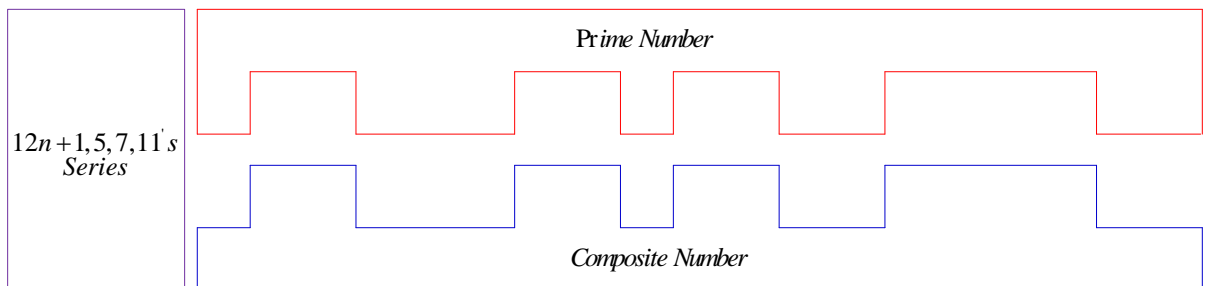

Figure 2.2.a) Prime numbers and composite numbers have complementary relationship regarding $12n + 1, 5, 7, 11$ series.

In the following [Attached document 1], the prime numbers under 1000 are being filtered using C_n . More specifically, you can see that arithmetic progressions, $Ga_n \sim Gp_n$, are intertwined. Of course, since the number of arithmetic progressions of each group increases as N increases, the complexity of intertwining of further arithmetic progressions increases. The composite numbers intuitively appear to be irregular and seem to be difficult to group into a pattern. However, the composite numbers are sorted into sixteen arithmetic

groups $(Ga_n \sim Gp_n)$ and are generated regularly by arithmetic progressions of each group.

2.3 The Structure of a matrix-multiplication of $A_n \times A_n$

Unlike prime numbers, which are unpredictable, the composite numbers are formed by sixteen arithmetic progression groups. This means that composite numbers in principle are predictable because whole composite numbers follow this rule. However, the composite numbers are made up of sixteen arithmetic progressions and it is difficult to see the whole of the arithmetic progressions, whose number increases, without necessary computations and information media that can store the computed results. If you can find the computed results of various arithmetic progressions intuitively, you can predict the rule that governs the composite numbers. This immediately means that you will be able to find the rule that governs the prime numbers. It is not a problem of whether or not the composite numbers are predictable but a problem of human perception.

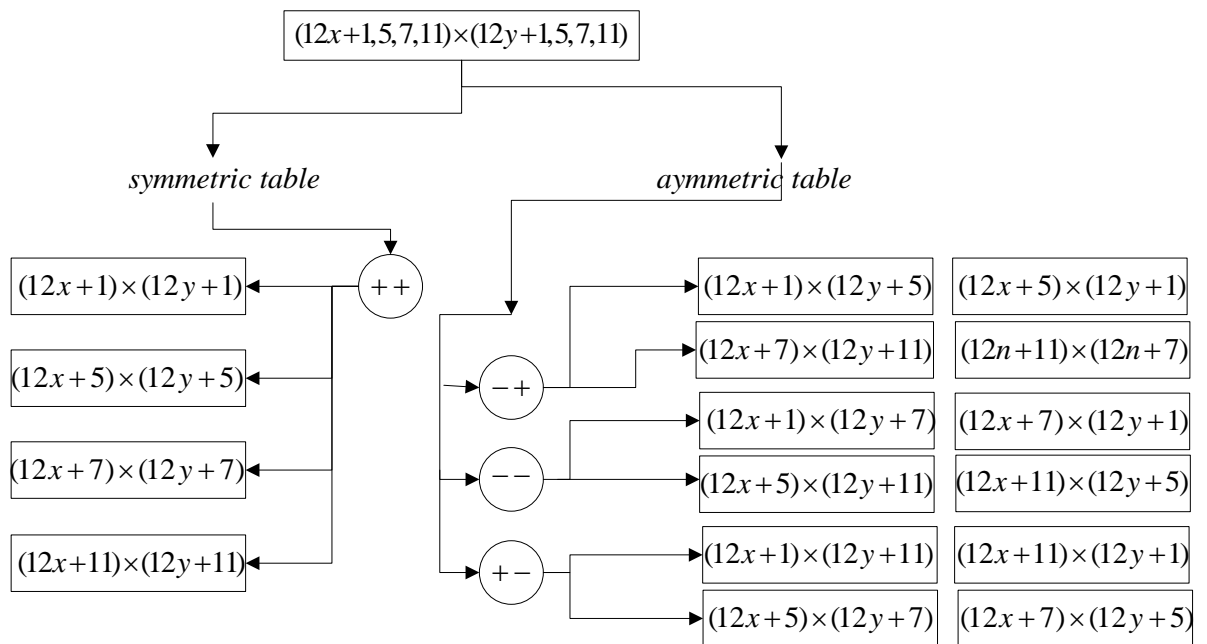

Figure – 2.3.a) Structure of Multiplication Table

- ⊗ G is a temporary mark used in this paper.
- ⊗ $a \sim p$ are marked in alphabetical order.
- ⊗ n is marked to clarify that composite numbers are a set of arithmetic progressions.

N	Group Name	a_1 (first term)	d (common difference)	$n = 1, 2, 3, \dots, n$
1	Ga_n	$(12x+1)(12y+1)$	$12 \times (12x+1)$	$x = n, y = n$
2	Gb_n	$(12x+5)(12y+5)$	$12 \times (12x+5)$	$x = n-1, y = n-1$
3	Gc_n	$(12x+7)(12y+7)$	$12 \times (12x+7)$	$x = n-1, y = n-1$
4	Gd_n	$(12x+11)(12y+11)$	$12 \times (12x+11)$	$x = n-1, y = n-1$
5	Ge_n	$(12x+5)(12y+1)$	$12 \times (12x+5)$	$x = n-1, y = n$
6	Gf_n	$(12x+1)(12y+5)$	$12 \times (12x+1)$	$x = n, y = n-1$
7	Gg_n	$(12x+11)(12y+7)$	$12 \times (12x+1)$	$x = n-1, y = n-1$
8	Gh_n	$(12x+7)(12y+11)$	$12 \times (12x+7)$	$x = n-1, y = n-1$
9	Gi_n	$(12x+7)(12y+1)$	$12 \times (12x+7)$	$x = n-1, y = n$
10	Gj_n	$(12x+1)(12y+7)$	$12 \times (12x+1)$	$x = n, y = n-1$
11	Gk_n	$(12x+5)(12y+11)$	$12 \times (12x+5)$	$x = n-1, y = n-1$
12	Gl_n	$(12x+11)(12y+5)$	$12 \times (12x+11)$	$x = n-1, y = n-1$
13	Gm_n	$(12x+1)(12y+11)$	$12 \times (12x+1)$	$x = n, y = n-1$
14	Gn_n	$(12x+11)(12y+1)$	$12 \times (12x+11)$	$x = n-1, y = n$
15	Go_n	$(12x+5)(12y+7)$	$12 \times (12x+5)$	$x = n-1, y = n-1$
16	Gp_n	$(12x+7)(12y+5)$	$12 \times (12x+7)$	$x = n-1, y = n-1$

Table – 3) The composite numbers of the $12n+1, 5, 7, 11$ series are sorted into a total of sixteen groups($Ga_n \sim Gp_n$).

2.4 Symmetric table and Asymmetric table

Analyzing the table of the $12n+1, 5, 7, 11$ series, by the values of horizontal axis(α) and vertical axis(β), the table divides into a symmetric table if $\alpha = \beta$, and into an asymmetric table if $\alpha \neq \beta$. Therefore, we can find the following results.

i) Symmetric table, $\alpha = \beta$

$$(12x+1) \times (12y+1), (x, y \geq 1)$$

$$(12x+5) \times (12y+5),$$

$$(12x+7) \times (12y+7),$$

$$(12x+11) \times (12y+11)$$

Since $\alpha = \beta$, the results are the same, reflecting along the diagonal elements independent of the orders of α and β . So, the symmetric table has four cases.

ii) Asymmetric table, $\alpha \neq \beta$

$$(12x+1) \times (12y+5), (x \geq 1), (12x+7) \times (12y+11)$$

$$(12x+1) \times (12y+7), (x \geq 1), (12x+5) \times (12y+11)$$

$$(12x+1) \times (12y+11), (x \geq 1), (12x+5) \times (12y+7)$$

However, the commutative law does not hold if $\alpha \neq \beta$. So, depending on the orders of α and β , the results are different for the diagonal elements. An asymmetric table has twelve cases.

α	β	Sign	Equation
1	5	-+	$(12x+1) \times (12y+5), (x \geq 1)$
5	1	-+	$(12x+5) \times (12y+1), (x \geq 1)$
7	11	-+	$(12x+7) \times (12y+11)$
11	7	-+	$(12x+11) \times (12y+7)$
1	7	--	$(12x+1) \times (12y+7), (x \geq 1)$
7	1	--	$(12x+7) \times (12y+1), (x \geq 1)$
5	11	--	$(12x+5) \times (12y+11)$
11	5	--	$(12x+11) \times (12y+5)$
1	11	+-	$(12x+1) \times (12y+11), (x \geq 1)$
11	1	+-	$(12x+11) \times (12y+1), (x \geq 1)$
5	7	+-	$(12x+5) \times (12y+7)$
7	5	+-	$(12x+7) \times (12y+5)$

Table - 4) The Equation of Asymmetric Table

The composite numbers of the $12n+1,5,7,11$ series divide into a total of sixteen arithmetic progression groups in the matrix multiplication, $(12x+\alpha) \times (12y+\beta)$, $(\alpha, \beta = 1,5,7,11)$, depending on $\alpha = \beta$ and $\alpha \neq \beta$.

3. Composites in Arithmetic Progression

3.1 $(12x+1)(12y+1), (Ga_n)$

×	13	25	37	49	61	73	85	97	$12x+1$
13	169								
25	325	625							
37	481	925	1369						
49	637	1225	1813	2401					
61	793	1525	2257	2989	3721				
73	949	1825	2701	3577	4453	5329			
85	1105	2125	3145	4165	5185	6205	7225		
97	1261	2425	3589	4753	5917	7081	8245	9409	
$12y+1$									

Figure 3.1.a) From the matrix multiplication, each of the diagonal elements becomes the initial terms of the arithmetic progressions.

- $\mathcal{C}\hat{a}_1 : 169(a_1) \quad 325(a_2) \quad 481(a_3) \quad 637(a_4) \quad 793(a_5) \quad 949(a_6) \quad 1105(a_7) \quad 1261(a_8)$
- $\mathcal{C}\hat{a}_2 : 625(a_1) \quad 925(a_2) \quad 1225(a_3) \quad 1525(a_4) \quad 1825(a_5) \quad 2125(a_6) \quad 2425(a_7)$
- $\mathcal{C}\hat{a}_3 : 1369(a_1) \quad 1813(a_2) \quad 2257(a_3) \quad 2701(a_4) \quad 3145(a_5) \quad 3589(a_6)$
- $\mathcal{C}\hat{a}_4 : 2401(a_1) \quad 2989(a_2) \quad 3577(a_3) \quad 4165(a_4) \quad 4753(a_5)$
- $\mathcal{C}\hat{a}_5 : 3721(a_1) \quad 4453(a_2) \quad 5185(a_3) \quad 5917(a_4)$
- $\mathcal{C}\hat{a}_6 : 5329(a_1) \quad 6205(a_2) \quad 7018(a_3)$
- $\mathcal{C}\hat{a}_7 : 7225(a_1) \quad 8545(a_2)$
- $\mathcal{C}\hat{a}_8 : 9409(a_1)$

Figure 3.1.b) We have listed the symmetric matrix results for each arithmetic progression. (a_1 =first term, d =common difference)

$Ga_1 : a_1 = (12x+1)(12y+1) = 169, \quad d = 12 \times (12x+1) = 156, (x=1, y=1)$
$Ga_2 : a_1 = (12x+1)(12y+1) = 625, \quad d = 12 \times (12x+1) = 300, (x=2, y=2)$
$Ga_3 : a_1 = (12x+1)(12y+1) = 1369, \quad d = 12 \times (12x+1) = 444, (x=3, y=3)$
$Ga_4 : a_1 = (12x+1)(12y+1) = 2401, \quad d = 12 \times (12x+1) = 588, (x=4, y=4)$
$Ga_5 : a_1 = (12x+1)(12y+1) = 3721, \quad d = 12 \times (12x+1) = 732, (x=5, y=5)$
$Ga_6 : a_1 = (12x+1)(12y+1) = 5329, \quad d = 12 \times (12x+1) = 876, (x=6, y=6)$
$Ga_7 : a_1 = (12x+1)(12y+1) = 7225, \quad d = 12 \times (12x+1) = 1020, (x=7, y=7)$
$Ga_8 : a_1 = (12x+1)(12y+1) = 9409, \quad d = 12 \times (12x+1) = 1164, (x=8, y=8)$
\vdots
$Ga_n : a_1 = (12x+1)(12y+1) = 144xy + 12x + 12y + 1, \quad d = 12 \times (12x+1), (x=n, y=n)$

Figure 3.1.c) Table multiplication results are arithmetic progressions that have initial terms and common differences and have a general formula. (a_1 =first term, d =common difference)

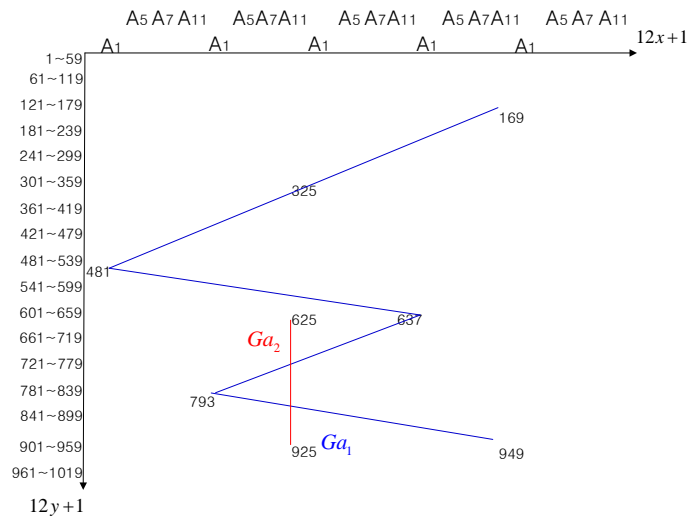

Figure 3.1.d) The contour of the arithmetic progression that belongs to Ga_n

The Figure 3.1.d) shows the contour of the arithmetic progression, cutting by 60 up to 1000. If N increases, more arithmetic progressions are generated. A point to note here is that they appear as different contours because they have different initial terms and common differences that belong to Ga_n .

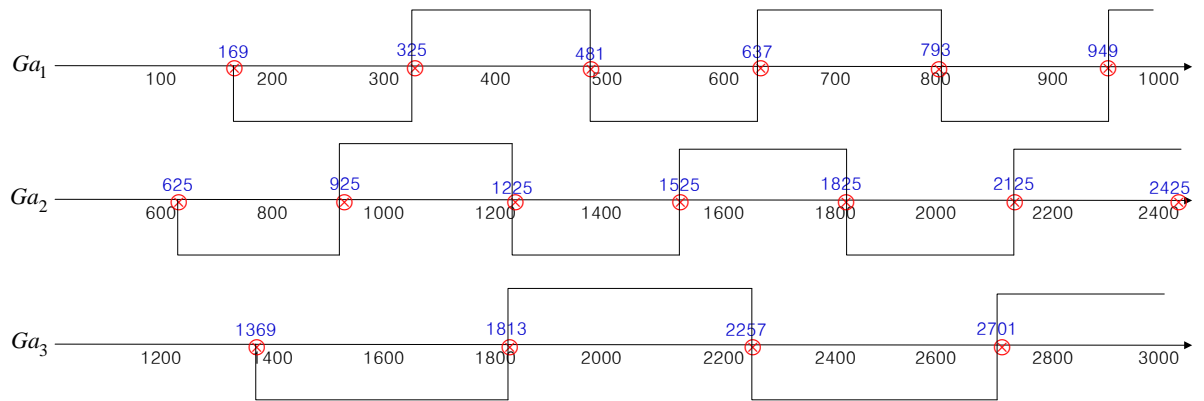

Figure 3.1.e) In Ga_n , there exist, under rules, a number of arithmetic progressions that have different initial terms and common differences.

$Ga_1, Ga_2, Ga_3 \sim Ga_n$ make up arithmetic progression groups that have initial terms, $(12x + 1)(12y + 1), (x, y = n)$ and common differences, $12(12x + 1), (x = n)$. Of course, as n increases, the values of the initial term and the common difference increase.

N	current value	new value
$Ga_1 : a_1(169)$	Ga_1	Ga_1
$Ga_2 : a_1(625)$	Ga_1, Ga_2	Ga_2
$Ga_3 : a_1(1369)$	Ga_1, Ga_2, Ga_3	Ga_3
$Ga_4 : a_1(2401)$	Ga_1, Ga_2, Ga_3, Ga_4	Ga_4
$Ga_5 : a_1(3721)$	$Ga_1, Ga_2, Ga_3, Ga_4, Ga_5$	Ga_5
\vdots	\vdots	\vdots
$Ga_n : a_1$	$Ga_1, Ga_2, Ga_3, Ga_4, Ga_5, \dots, Ga_n$	Ga_n

Figure 3.1.f) As the natural number N , increases, new arithmetic progressions accumulate and keep increasing.

In Figure 3.1.f), since new arithmetic progressions accumulate as the natural number N increases, the distribution density of the composite numbers in each region becomes high. For example, the number of composite numbers of the arithmetic progression, Ga_n , is higher in the 1,000-2,000 region than in the 11,000-12,000 region. Just like a timer that rings after a certain period of time, for a certain N , the corresponding arithmetic progression operates.

Theorem 2) As N increases, the density of composite numbers becomes higher. In other words, it means that, as N increases, prime number density becomes low. (of the sparsity of the prime sequence.)

When writing the list of prime numbers, you will find that prime numbers become more and more sparse.

n	$\pi(n)$	$\pi(n)/n$
10	4	0.4
10^2	25	0.25
10^3	168	0.168
10^4	1,229	0.1229
10^5	9,592	0.09592
10^6	78,498	0.078498
10^7	664,579	0.066458
10^8	5,761,455	0.057615
10^9	50,847,534	0.050848
10^{10}	455,052,512	0.045505

Table – 5) The Sparse of Prime Numbers

The number of prime numbers between 1 and 100 is greater than that between 101 and 200. There are 4 prime numbers (40%) between 0 and 10, 25 prime numbers (25%) between 0 and 100, 168(16.8%) between 0 and 1000, 1,229 (12.3%) between 0 and 10000, 9592 (9.5%) between 0 and 100000, and 78,498 (7.8%) between 0 and 1000000. The percentage gradually decreases. [9][10]

Section	The count of prime	The count of composite	Total
$0 \sim 10^2$	25(0.25)	9(0.09)	34
$10^2 \sim 2 \times 10^2$	21(0.21)	13(0.13)	34
$2 \times 10^2 \sim 3 \times 10^2$	16(0.16)	17(0.17)	33
$3 \times 10^2 \sim 4 \times 10^2$	16(0.16)	17(0.17)	33
$4 \times 10^2 \sim 5 \times 10^2$	17(0.17)	17(0.17)	34
$5 \times 10^2 \sim 6 \times 10^2$	14(0.14)	19(0.19)	33
$6 \times 10^2 \sim 7 \times 10^2$	16(0.16)	17(0.17)	33
$7 \times 10^2 \sim 8 \times 10^2$	14(0.14)	20(0.20)	34
$8 \times 10^2 \sim 9 \times 10^2$	15(0.15)	18(0.18)	33
$9 \times 10^2 \sim 10^3$	14(0.14)	19(0.19)	33

Table – 6) Densities of Prime and Composite Numbers in Each Region

Therefore, if you know reason that the number of composite numbers increases, you will know why prime number density decreases. This is because, at least, we know the rules under which composite numbers are generated. This phenomenon is a natural result because new arithmetic progressions accumulate as a natural number, N , increases. As Ga_n , $Gb_n, Gc_n \sim Gp_n$ make up groups that all have different initial terms and common differences. Therefore, they make up sixteen groups of arithmetic progressions.

3.2 $(12x+5)(12y+5), (Gb_n)$

×	5	17	29	41	53	65	77	89
5	25							
17	85	289						
29	145	493	841					
41	205	697	1189	1681				
53	265	901	1537	2173	2809			
65	325	1105	1885	2665	3445	4225		
77	385	1309	2233	3157	4081	5005	5929	
89	445	1513	2581	3649	4717	5785	6853	7921

- $Gb_1: 25(a_1) \quad 85(a_2) \quad 145(a_3) \quad 205(a_4) \quad 265(a_5) \quad 325(a_6) \quad 385(a_7) \quad 445(a_8)$
- $Gb_2: 289(a_1) \quad 493(a_2) \quad 697(a_3) \quad 901(a_4) \quad 1105(a_5) \quad 1309(a_6) \quad 1513(a_7)$
- $Gb_3: 841(a_1) \quad 1189(a_2) \quad 1537(a_3) \quad 1885(a_4) \quad 2233(a_5) \quad 2581(a_6)$
- $Gb_4: 1681(a_1) \quad 2173(a_2) \quad 2665(a_3) \quad 3157(a_4) \quad 3649(a_5)$
- $Gb_5: 2809(a_1) \quad 3445(a_2) \quad 4081(a_3) \quad 4717(a_4)$
- $Gb_6: 4225(a_1) \quad 5005(a_2) \quad 5785(a_3)$
- $Gb_7: 5929(a_1) \quad 6853(a_2)$
- $Gb_8: 7921(a_1)$

- $Gb_1: a_1 = (12x+5)(12y+5) = 25, \quad d = 12 \times (12y+5) = 60, (x=0, y=0)$
- $Gb_2: a_1 = (12x+5)(12y+5) = 289, \quad d = 12 \times (12y+5) = 204, (x=1, y=1)$
- $Gb_3: a_1 = (12x+5)(12y+5) = 841, \quad d = 12 \times (12y+5) = 348, (x=2, y=2)$
- $Gb_4: a_1 = (12x+5)(12y+5) = 1681, \quad d = 12 \times (12y+5) = 492, (x=3, y=3)$
- $Gb_5: a_1 = (12x+5)(12y+5) = 2809, \quad d = 12 \times (12y+5) = 636, (x=4, y=4)$
- $Gb_6: a_1 = (12x+5)(12y+5) = 4225, \quad d = 12 \times (12y+5) = 780, (x=5, y=5)$
- $Gb_7: a_1 = (12x+5)(12y+5) = 5929, \quad d = 12 \times (12y+5) = 924, (x=6, y=6)$
- $Gb_8: a_1 = (12x+5)(12y+5) = 7921, \quad d = 12 \times (12y+5) = 1068, (x=7, y=7)$
- \vdots
- $Gb_n: a_1 = (12x+5)(12y+5) = 144xy + 60x + 60y + 25, \quad d = 12 \times (12x+5), (x=n-1, y=n-1)$

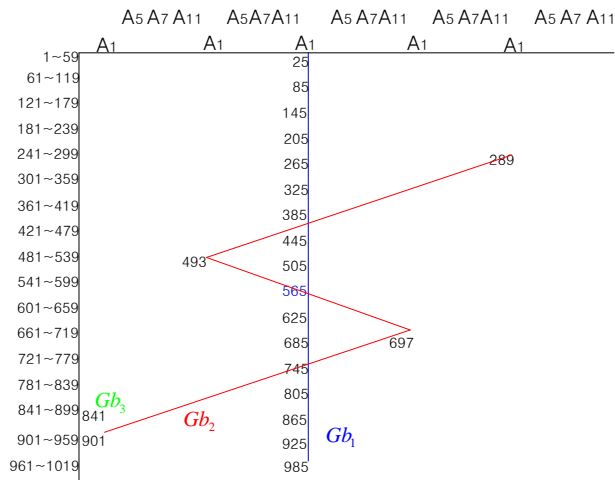

3.3 $(12x+7)(12y+7), (Gc_n)$

×	7	19	31	43	55	67	79	91
7	49							
19	133	361						
31	217	589	961					
43	301	817	1333	1849				
55	385	1045	1705	2365	3025			
67	469	1273	2077	2881	3685	4489		
79	553	1501	2449	3397	4345	5293	6241	
91	637	1729	2821	3913	5005	6097	7189	8281

- $G_1: 49(a_1) \quad 133(a_2) \quad 217(a_3) \quad 301(a_4) \quad 385(a_5) \quad 469(a_6) \quad 553(a_7) \quad 637(a_8)$
- $G_2: 361(a_1) \quad 589(a_2) \quad 817(a_3) \quad 1045(a_4) \quad 1273(a_5) \quad 1501(a_6) \quad 1729(a_7)$
- $G_3: 961(a_1) \quad 1333(a_2) \quad 1705(a_3) \quad 2077(a_4) \quad 2449(a_5) \quad 2821(a_6)$
- $G_4: 1849(a_1) \quad 2365(a_2) \quad 2881(a_3) \quad 3397(a_4) \quad 3913(a_5)$
- $G_5: 3025(a_1) \quad 3685(a_2) \quad 4345(a_3) \quad 5005(a_4)$
- $G_6: 4489(a_1) \quad 5293(a_2) \quad 6097(a_3)$
- $G_7: 6241(a_1) \quad 7189(a_2)$
- $G_8: 8281(a_1)$

- $G_1: a_1 = (12x+7)(12y+7) = 49, \quad d = 12 \times (12y+7) = 84, (x=0, y=0)$
- $G_2: a_1 = (12x+7)(12y+7) = 361, \quad d = 12 \times (12y+7) = 228, (x=1, y=1)$
- $G_3: a_1 = (12x+7)(12y+7) = 961, \quad d = 12 \times (12y+7) = 372, (x=2, y=2)$
- $G_4: a_1 = (12x+7)(12y+7) = 1849, \quad d = 12 \times (12y+7) = 516, (x=3, y=3)$
- $G_5: a_1 = (12x+7)(12y+7) = 3025, \quad d = 12 \times (12y+7) = 660, (x=4, y=4)$
- $G_6: a_1 = (12x+7)(12y+7) = 4489, \quad d = 12 \times (12y+7) = 804, (x=5, y=5)$
- $G_7: a_1 = (12x+7)(12y+7) = 6241, \quad d = 12 \times (12y+7) = 948, (x=6, y=6)$
- $G_8: a_1 = (12x+7)(12y+7) = 8281, \quad d = 12 \times (12y+7) = 1092, (x=7, y=7)$
- ⋮
- $G_n: a_1 = (12x+7)(12y+7) = 144xy + 84x + 84y + 49, \quad d = 12 \times (12x+7), (x=n-1, y=n-1)$

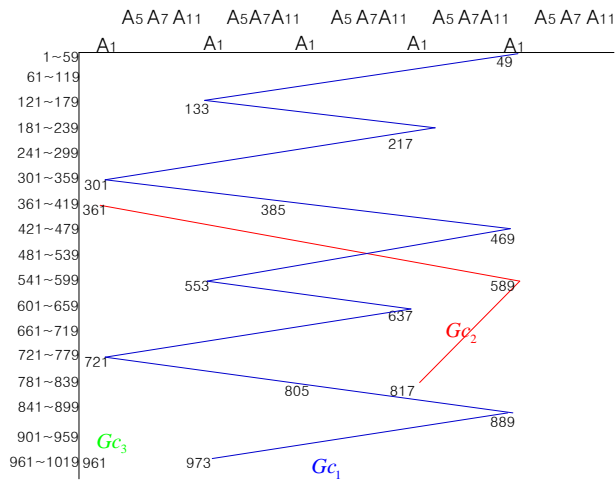

3.4 $(12x+11)(12y+11), (Gd_n)$

×	11	23	35	47	59	71	83	95
11	121							
23	253	529						
35	385	805	1225					
47	517	1081	1645	2209				
59	649	1357	2065	2773	3481			
71	781	1633	2485	3337	4189	5041		
83	913	1909	2905	3901	4897	5893	6889	
95	1045	2185	3325	4465	5605	6745	7885	9025

- $Gd_1: 121(a_1)$ $253(a_2)$ $385(a_3)$ $517(a_4)$ $649(a_5)$ $781(a_6)$ $913(a_7)$ $1045(a_8)$
 $Gd_2: 529(a_1)$ $805(a_2)$ $1081(a_3)$ $1357(a_4)$ $1633(a_5)$ $1909(a_6)$ $2185(a_7)$
 $Gd_3: 1225(a_1)$ $1645(a_2)$ $2065(a_3)$ $2485(a_4)$ $2905(a_5)$ $3325(a_6)$
 $Gd_4: 2209(a_1)$ $2773(a_2)$ $3337(a_3)$ $3901(a_4)$ $4465(a_5)$
 $Gd_5: 3481(a_1)$ $4189(a_2)$ $4897(a_3)$ $5605(a_4)$
 $Gd_6: 5041(a_1)$ $5893(a_2)$ $6745(a_3)$
 $Gd_7: 6889(a_1)$ $7885(a_2)$
 $Gd_8: 9025(a_1)$

- $Gd_1: a_1 = (12x+11)(12y+11) = 121, \quad d = 12 \times (12y+11) = 132, (x=0, y=0)$
 $Gd_2: a_1 = (12x+11)(12y+11) = 529, \quad d = 12 \times (12y+11) = 276, (x=1, y=1)$
 $Gd_3: a_1 = (12x+11)(12y+11) = 1225, \quad d = 12 \times (12y+11) = 420, (x=2, y=2)$
 $Gd_4: a_1 = (12x+11)(12y+11) = 2209, \quad d = 12 \times (12y+11) = 564, (x=3, y=3)$
 $Gd_5: a_1 = (12x+11)(12y+11) = 3481, \quad d = 12 \times (12y+11) = 708, (x=4, y=4)$
 $Gd_6: a_1 = (12x+11)(12y+11) = 5041, \quad d = 12 \times (12y+11) = 852, (x=5, y=5)$
 $Gd_7: a_1 = (12x+11)(12y+11) = 6889, \quad d = 12 \times (12y+11) = 996, (x=6, y=6)$
 $Gd_8: a_1 = (12x+11)(12y+11) = 9025, \quad d = 12 \times (12y+11) = 1140, (x=7, y=7)$
 \vdots
 $Gd_n: a_1 = (12x+11)(12y+11) = 144xy + 132x + 132y + 121, \quad d = 12 \times (12y+11), (x=n-1, y=n-1)$

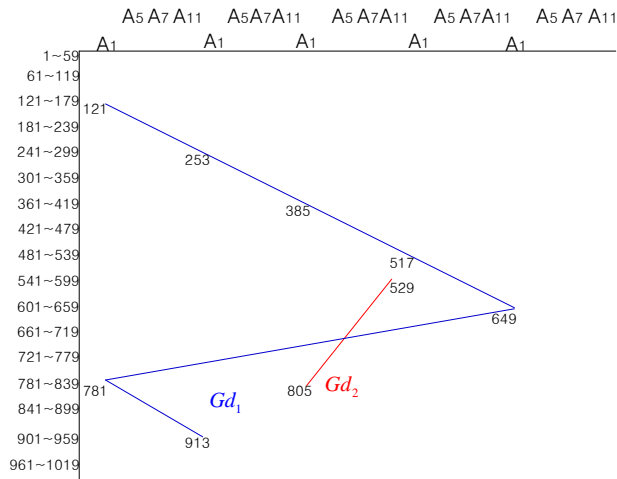

3.5 $(12x+1)(12y+5), (Ge_n)$

×	13	25	37	49	61	73	85	97
5	65							
17	221	425						
29	377	725	1073					
41	533	1025	1517	2009				
53	689	1325	1961	2597	3233			
65	845	1625	2405	3185	3965	4745		
77	1001	1925	2849	3773	4697	5621	6545	
89	1157	2225	3293	4361	5429	6497	7565	8633

- $Ge_1: 65(a_1) \quad 221(a_2) \quad 377(a_3) \quad 533(a_4) \quad 689(a_5) \quad 845(a_6) \quad 1001(a_7) \quad 1157(a_8)$
- $Ge_2: 425(a_1) \quad 725(a_2) \quad 1025(a_3) \quad 1325(a_4) \quad 1625(a_5) \quad 1925(a_6) \quad 2225(a_7)$
- $Ge_3: 1073(a_1) \quad 1517(a_2) \quad 1961(a_3) \quad 2405(a_4) \quad 2849(a_5) \quad 3293(a_6)$
- $Ge_4: 2009(a_1) \quad 2597(a_2) \quad 3185(a_3) \quad 3773(a_4) \quad 4361(a_5)$
- $Ge_5: 3233(a_1) \quad 3965(a_2) \quad 4697(a_3) \quad 5429(a_4)$
- $Ge_6: 4745(a_1) \quad 5621(a_2) \quad 6497(a_3)$
- $Ge_7: 6545(a_1) \quad 7565(a_2)$
- $Ge_8: 8633(a_1)$

- $Ge_1: a_1 = (12x+1)(12y+5) = 65, \quad d = 12 \times (12x+1) = 156 (x=1, y=0)$
- $Ge_2: a_1 = (12x+1)(12y+5) = 425, \quad d = 12 \times (12x+1) = 300 (x=2, y=1)$
- $Ge_3: a_1 = (12x+1)(12y+5) = 1073, \quad d = 12 \times (12x+1) = 444 (x=3, y=2)$
- $Ge_4: a_1 = (12x+1)(12y+5) = 2009, \quad d = 12 \times (12x+1) = 588 (x=4, y=3)$
- $Ge_5: a_1 = (12x+1)(12y+5) = 3233, \quad d = 12 \times (12x+1) = 732 (x=5, y=4)$
- $Ge_6: a_1 = (12x+1)(12y+5) = 4745, \quad d = 12 \times (12x+1) = 876 (x=6, y=5)$
- $Ge_7: a_1 = (12x+1)(12y+5) = 6545, \quad d = 12 \times (12x+1) = 1020 (x=7, y=6)$
- $Ge_8: a_1 = (12x+1)(12y+5) = 8633, \quad d = 12 \times (12x+1) = 1164 (x=8, y=7)$
- \vdots
- $Ge_n: a_1 = (12x+1)(12y+5) = 144xy + 60x + 12y + 5, \quad d = 12 \times (12x+1) (x=n, y=n-1)$

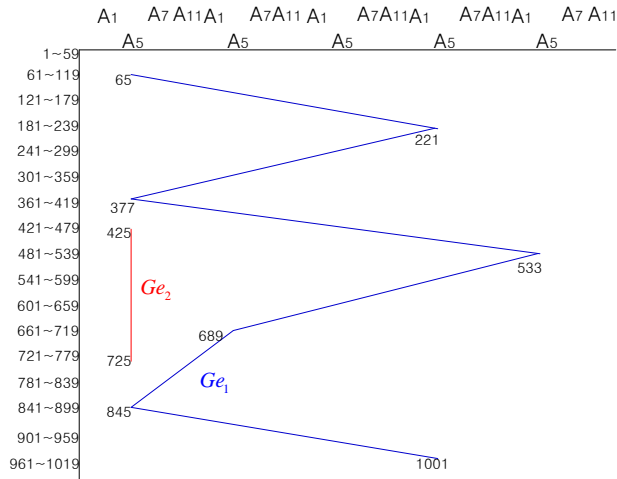

3.6 $(12x+5)(12y+1), (Gf_n)$

×	5	17	29	41	53	65	77	89
13	65							
25	125	425						
37	185	629	1073					
49	245	833	1421	2009				
61	305	1037	1769	2501	3233			
73	365	1241	2117	2993	3869	4745		
85	425	1445	2465	3485	4505	5525	6545	
97	485	1649	2813	3977	5141	6305	7469	8633

- $Gf_1: 65(a_1)$ $125(a_2)$ $185(a_3)$ $245(a_4)$ $305(a_5)$ $365(a_6)$ $425(a_7)$ $485(a_8)$
 $Gf_2: 425(a_1)$ $629(a_2)$ $833(a_3)$ $1037(a_4)$ $1241(a_5)$ $1445(a_6)$ $1649(a_7)$
 $Gf_3: 1073(a_1)$ $1421(a_2)$ $1769(a_3)$ $2117(a_4)$ $2465(a_5)$ $2813(a_6)$
 $Gf_4: 2009(a_1)$ $2501(a_2)$ $2993(a_3)$ $3485(a_4)$ $3977(a_5)$
 $Gf_5: 3233(a_1)$ $3869(a_2)$ $4505(a_3)$ $5141(a_4)$
 $Gf_6: 4745(a_1)$ $5525(a_2)$ $6305(a_3)$
 $Gf_7: 6545(a_1)$ $7469(a_2)$
 $Gf_8: 8633(a_1)$

- $Gf_1: a_1 = (12x+5)(12y+1) = 65, \quad d = 12 \times (12x+5) = 60(x=0, y=1)$
 $Gf_2: a_1 = (12x+5)(12y+1) = 425, \quad d = 12 \times (12x+5) = 204(x=1, y=2)$
 $Gf_3: a_1 = (12x+5)(12y+1) = 1073, \quad d = 12 \times (12x+5) = 348(x=2, y=3)$
 $Gf_4: a_1 = (12x+5)(12y+1) = 2009, \quad d = 12 \times (12x+5) = 492(x=3, y=4)$
 $Gf_5: a_1 = (12x+5)(12y+1) = 3233, \quad d = 12 \times (12x+5) = 636(x=4, y=5)$
 $Gf_6: a_1 = (12x+5)(12y+1) = 4745, \quad d = 12 \times (12x+5) = 780(x=5, y=6)$
 $Gf_7: a_1 = (12x+5)(12y+1) = 6545, \quad d = 12 \times (12x+5) = 924(x=6, y=7)$
 $Gf_8: a_1 = (12x+5)(12y+1) = 8633, \quad d = 12 \times (12x+5) = 1068(x=7, y=8)$
 \vdots
 $Gf_n: a_1 = (12x+5)(12y+1) = 144xy + 12x + 60y + 5, \quad d = 12 \times (12y+5)(x=n-1, y=n)$

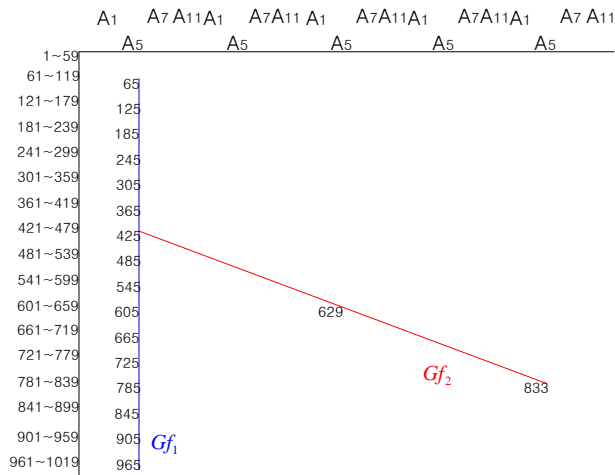

3.7 $(12x+7)(12y+11), (Gg_n)$

×	7	19	31	43	55	67	79	91
11	77							
23	161	437						
35	245	665	1085					
47	329	893	1457	2021				
59	413	1121	1829	2537	3245			
71	497	1349	2201	3053	3905	4757		
83	581	1577	2573	3569	4565	5561	6557	
95	665	1805	2945	4085	5225	6365	7505	8645

- $\mathbb{C}g_1: 77(a_1) \quad 161(a_2) \quad 245(a_3) \quad 329(a_4) \quad 413(a_5) \quad 497(a_6) \quad 581(a_7) \quad 665(a_8)$
- $\mathbb{C}g_2: 437(a_1) \quad 665(a_2) \quad 893(a_3) \quad 1121(a_4) \quad 1349(a_5) \quad 1577(a_6) \quad 1805(a_7)$
- $\mathbb{C}g_3: 1085(a_1) \quad 1457(a_2) \quad 1829(a_3) \quad 2201(a_4) \quad 2573(a_5) \quad 2945(a_6)$
- $\mathbb{C}g_4: 2021(a_1) \quad 2537(a_2) \quad 3053(a_3) \quad 3569(a_4) \quad 4085(a_5)$
- $\mathbb{C}g_5: 3245(a_1) \quad 3905(a_2) \quad 4565(a_3) \quad 5225(a_4)$
- $\mathbb{C}g_6: 4757(a_1) \quad 5561(a_2) \quad 6365(a_3)$
- $\mathbb{C}g_7: 6557(a_1) \quad 7505(a_2)$
- $\mathbb{C}g_8: 8645(a_1)$

- $\mathbb{C}g_1: a_1 = (12x+7)(12y+11) = 77, \quad d = 12 \times (12x+7) = 84(x=0, y=0)$
- $\mathbb{C}g_2: a_1 = (12x+7)(12y+11) = 437, \quad d = 12 \times (12x+7) = 228(x=1, y=1)$
- $\mathbb{C}g_3: a_1 = (12x+7)(12y+11) = 1085, \quad d = 12 \times (12x+7) = 372(x=2, y=2)$
- $\mathbb{C}g_4: a_1 = (12x+7)(12y+11) = 2021, \quad d = 12 \times (12x+7) = 516(x=3, y=3)$
- $\mathbb{C}g_5: a_1 = (12x+7)(12y+11) = 3245, \quad d = 12 \times (12x+7) = 660(x=4, y=4)$
- $\mathbb{C}g_6: a_1 = (12x+7)(12y+11) = 4757, \quad d = 12 \times (12x+7) = 804(x=5, y=5)$
- $\mathbb{C}g_7: a_1 = (12x+7)(12y+11) = 6557, \quad d = 12 \times (12x+7) = 948(x=6, y=6)$
- $\mathbb{C}g_8: a_1 = (12x+7)(12y+11) = 8645, \quad d = 12 \times (12x+7) = 1092(x=7, y=7)$
- ⋮
- $\mathbb{C}g_n: a_1 = (12x+7)(12y+11) = 144xy + 132x + 84y + 77, \quad d = 12 \times (12x+7)(x=n-1, y=n-1)$

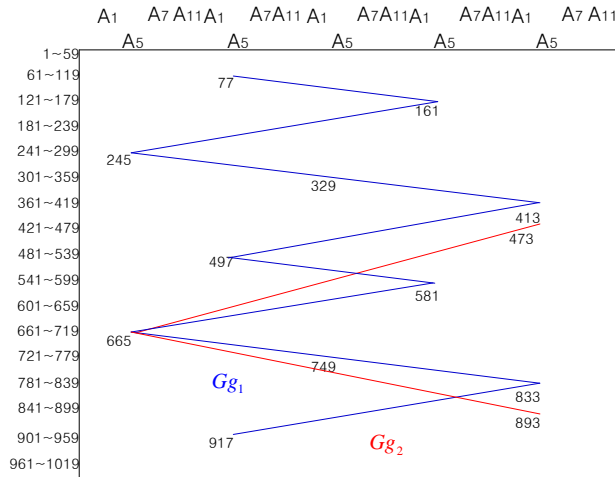

3.8 $(12x+11)(12y+7), (Gh_n)$

×	11	23	35	47	59	71	83	95
7	77							
19	209	437						
31	341	713	1085					
43	473	989	1505	2021				
55	605	1265	1925	2585	3245			
67	737	1541	2345	3149	3953	4757		
79	869	1817	2765	3713	4661	5609	6557	
91	1001	2093	3185	4277	5369	6461	7553	8645

- $Gh_1: 77(a_1) \quad 209(a_2) \quad 341(a_3) \quad 473(a_4) \quad 605(a_5) \quad 737(a_6) \quad 869(a_7) \quad 1001(a_8)$
- $Gh_2: 437(a_1) \quad 713(a_2) \quad 989(a_3) \quad 1265(a_4) \quad 1541(a_5) \quad 1817(a_6) \quad 2093(a_7)$
- $Gh_3: 1085(a_1) \quad 1505(a_2) \quad 1925(a_3) \quad 2345(a_4) \quad 2765(a_5) \quad 3185(a_6)$
- $Gh_4: 2021(a_1) \quad 2585(a_2) \quad 3149(a_3) \quad 3713(a_4) \quad 4277(a_5)$
- $Gh_5: 3245(a_1) \quad 3965(a_2) \quad 4661(a_3) \quad 5369(a_4)$
- $Gh_6: 4757(a_1) \quad 5609(a_2) \quad 6461(a_3)$
- $Gh_7: 6557(a_1) \quad 7553(a_2)$
- $Gh_8: 8645(a_1)$

- $Gh_1: a_1 = (12x+11)(12y+7) = 77, \quad d = 12 \times (12x+11) = 132(x=0, y=0)$
- $Gh_2: a_1 = (12x+11)(12y+7) = 437, \quad d = 12 \times (12x+11) = 276(x=1, y=1)$
- $Gh_3: a_1 = (12x+11)(12y+7) = 1085, \quad d = 12 \times (12x+11) = 420(x=2, y=2)$
- $Gh_4: a_1 = (12x+11)(12y+7) = 2021, \quad d = 12 \times (12x+11) = 564(x=3, y=3)$
- $Gh_5: a_1 = (12x+11)(12y+7) = 3245, \quad d = 12 \times (12x+11) = 708(x=4, y=4)$
- $Gh_6: a_1 = (12x+11)(12y+7) = 4757, \quad d = 12 \times (12x+11) = 852(x=5, y=5)$
- $Gh_7: a_1 = (12x+11)(12y+7) = 6557, \quad d = 12 \times (12x+11) = 996(x=6, y=6)$
- $Gh_8: a_1 = (12x+11)(12y+7) = 8645, \quad d = 12 \times (12x+11) = 1140(x=7, y=7)$
- ⋮
- $Gh_n: a_1 = (12x+11)(12y+7) = 144xy + 84x + 132y + 77, \quad d = 12 \times (12x+11)(x=n-1, y=n-1)$

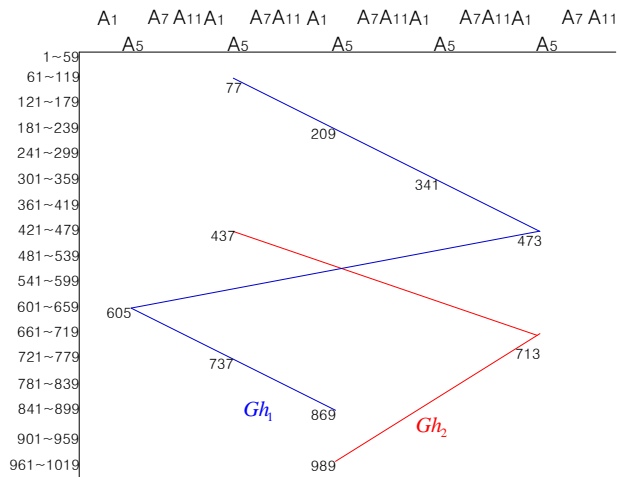

3.9 $(12x+1)(12y+7), (Gi_n)$

×	13	25	37	49	61	73	85	97
7	91							
19	247	475						
31	403	775	1147					
43	559	1075	1591	2107				
55	715	1375	2035	2695	3355			
67	871	1675	2479	3283	4087	4891		
79	1027	1975	2923	3871	4819	5767	6715	
91	1183	2275	3367	4459	5551	6643	7735	8827

- $Gi_1 : 91(a_1) \quad 247(a_2) \quad 403(a_3) \quad 559(a_4) \quad 715(a_5) \quad 871(a_6) \quad 1027(a_7) \quad 1183(a_8)$
 $Gi_2 : 475(a_1) \quad 775(a_2) \quad 1075(a_3) \quad 1375(a_4) \quad 1675(a_5) \quad 1975(a_6) \quad 2275(a_7)$
 $Gi_3 : 1147(a_1) \quad 1591(a_2) \quad 2035(a_3) \quad 2479(a_4) \quad 2923(a_5) \quad 3367(a_6)$
 $Gi_4 : 2107(a_1) \quad 2695(a_2) \quad 3283(a_3) \quad 3871(a_4) \quad 4459(a_5)$
 $Gi_5 : 3355(a_1) \quad 4087(a_2) \quad 4819(a_3) \quad 5551(a_4)$
 $Gi_6 : 4891(a_1) \quad 5767(a_2) \quad 6643(a_3)$
 $Gi_7 : 6715(a_1) \quad 7735(a_2)$
 $Gi_8 : 8827(a_1)$

- $Gi_1 : a_1 = (12x+1)(12y+7) = 91, \quad d = 12 \times (12x+1) = 156(x=1, y=0)$
 $Gi_2 : a_1 = (12x+1)(12y+7) = 475, \quad d = 12 \times (12x+1) = 300(x=2, y=1)$
 $Gi_3 : a_1 = (12x+1)(12y+7) = 1147, \quad d = 12 \times (12x+1) = 444(x=3, y=2)$
 $Gi_4 : a_1 = (12x+1)(12y+7) = 2107, \quad d = 12 \times (12x+1) = 588(x=4, y=3)$
 $Gi_5 : a_1 = (12x+1)(12y+7) = 3355, \quad d = 12 \times (12x+1) = 732(x=5, y=4)$
 $Gi_6 : a_1 = (12x+1)(12y+7) = 4891, \quad d = 12 \times (12x+1) = 876(x=6, y=5)$
 $Gi_7 : a_1 = (12x+1)(12y+7) = 6715, \quad d = 12 \times (12x+1) = 1020(x=7, y=6)$
 $Gi_8 : a_1 = (12x+1)(12y+7) = 8827, \quad d = 12 \times (12x+1) = 1164(x=8, y=7)$
 \vdots
 $Gi_n : a_1 = (12x+1)(12y+7) = 144xy + 84x + 12y + 7, \quad d = 12 \times (12x+1)(x=n, y=n-1)$

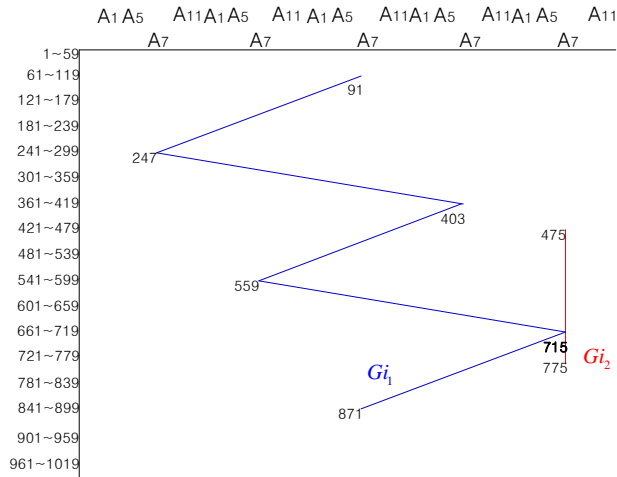

3.10 $(12x+7)(12y+1), (G_j^n)$

×	7	19	31	43	55	67	79	91
13	91							
25	175	475						
37	259	703	1147					
49	343	931	1519	2107				
61	427	1159	1891	2623	3355			
73	511	1387	2263	3139	4015	4891		
85	595	1615	2635	3655	4675	5695	6715	
97	679	1843	3007	4171	5335	6499	7663	8827

- $G_1: 91(a_1) \quad 175(a_2) \quad 259(a_3) \quad 343(a_4) \quad 427(a_5) \quad 511(a_6) \quad 595(a_7) \quad 679(a_8)$
- $G_2: 475(a_1) \quad 703(a_2) \quad 931(a_3) \quad 1159(a_4) \quad 1387(a_5) \quad 1615(a_6) \quad 1843(a_7)$
- $G_3: 1147(a_1) \quad 1519(a_2) \quad 1891(a_3) \quad 2263(a_4) \quad 2635(a_5) \quad 3007(a_6)$
- $G_4: 2107(a_1) \quad 2623(a_2) \quad 3139(a_3) \quad 3655(a_4) \quad 4171(a_5)$
- $G_5: 3355(a_1) \quad 4015(a_2) \quad 4675(a_3) \quad 5335(a_4)$
- $G_6: 4891(a_1) \quad 5695(a_2) \quad 6499(a_3)$
- $G_7: 6715(a_1) \quad 7663(a_2)$
- $G_8: 8827(a_1)$

- $G_1: a_i = (12x+7)(12y+1) = 91, \quad d = 12 \times (12x+7) = 84(x=0, y=1)$
- $G_2: a_i = (12x+7)(12y+1) = 475, \quad d = 12 \times (12x+7) = 228(x=1, y=2)$
- $G_3: a_i = (12x+7)(12y+1) = 1147, \quad d = 12 \times (12x+7) = 372(x=2, y=3)$
- $G_4: a_i = (12x+7)(12y+1) = 2107, \quad d = 12 \times (12x+7) = 516(x=3, y=4)$
- $G_5: a_i = (12x+7)(12y+1) = 3355, \quad d = 12 \times (12x+7) = 660(x=4, y=5)$
- $G_6: a_i = (12x+7)(12y+1) = 4891, \quad d = 12 \times (12x+7) = 804(x=5, y=6)$
- $G_7: a_i = (12x+7)(12y+1) = 6715, \quad d = 12 \times (12x+7) = 948(x=6, y=7)$
- $G_8: a_i = (12x+7)(12y+1) = 8827, \quad d = 12 \times (12x+7) = 1092(x=7, y=8)$
- ⋮
- $G_n: a_i = (12x+7)(12y+1) = 144xy + 12x + 84y + 7, \quad d = 12 \times (12x+7)(x=n-1, y=n)$

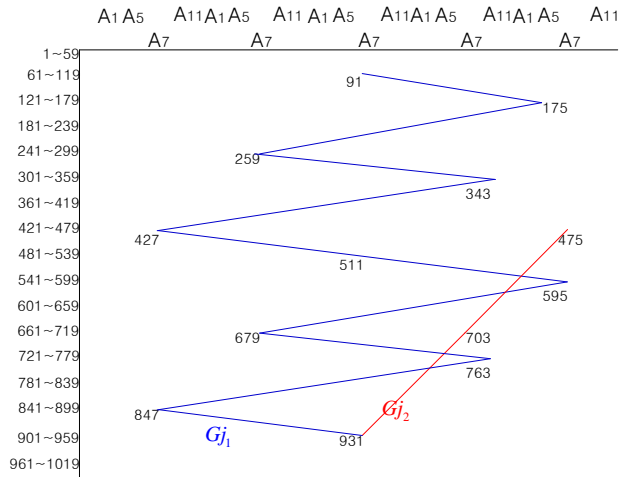

3.11 $(12x+5)(12y+11), (Gk_n)$

×	5	17	29	41	53	65	77	89
11	55							
23	115	391						
35	175	595	1015					
47	235	799	1363	1927				
59	295	1003	1711	2419	3127			
71	355	1207	2059	2911	3763	4615		
83	415	1411	2407	3403	4399	5395	6391	
95	475	1615	2755	3895	5035	6175	7315	8455

- $G_1: 55(a_1) \quad 115(a_2) \quad 175(a_3) \quad 235(a_4) \quad 295(a_5) \quad 355(a_6) \quad 415(a_7) \quad 475(a_8)$
- $G_2: 391(a_1) \quad 595(a_2) \quad 799(a_3) \quad 1003(a_4) \quad 1207(a_5) \quad 1411(a_6) \quad 1615(a_7)$
- $G_3: 1015(a_1) \quad 1363(a_2) \quad 1711(a_3) \quad 2059(a_4) \quad 2407(a_5) \quad 2755(a_6)$
- $G_4: 1927(a_1) \quad 2419(a_2) \quad 2911(a_3) \quad 3403(a_4) \quad 3895(a_5)$
- $G_5: 3127(a_1) \quad 3763(a_2) \quad 4399(a_3) \quad 5035(a_4)$
- $G_6: 4615(a_1) \quad 5395(a_2) \quad 6175(a_3)$
- $G_7: 6391(a_1) \quad 7315(a_2)$
- $G_8: 8455(a_1)$

- $G_1: a_1 = (12x+5)(12y+11) = 55, \quad d = 12 \times (12x+5) = 60(x=0, y=0)$
- $G_2: a_1 = (12x+5)(12y+11) = 391, \quad d = 12 \times (12x+5) = 204(x=1, y=1)$
- $G_3: a_1 = (12x+5)(12y+11) = 1015, \quad d = 12 \times (12x+5) = 348(x=2, y=2)$
- $G_4: a_1 = (12x+5)(12y+11) = 1927, \quad d = 12 \times (12x+5) = 492(x=3, y=3)$
- $G_5: a_1 = (12x+5)(12y+11) = 3127, \quad d = 12 \times (12x+5) = 636(x=4, y=4)$
- $G_6: a_1 = (12x+5)(12y+11) = 4615, \quad d = 12 \times (12x+5) = 780(x=5, y=5)$
- $G_7: a_1 = (12x+5)(12y+11) = 6391, \quad d = 12 \times (12x+5) = 924(x=6, y=6)$
- $G_8: a_1 = (12x+5)(12y+11) = 8455, \quad d = 12 \times (12x+5) = 1068(x=7, y=7)$
- ⋮
- $G_n: a_1 = (12x+5)(12y+11) = 144xy + 132x + 60y + 55, \quad d = 12 \times (12x+5)(x=n-1, y=n-1)$

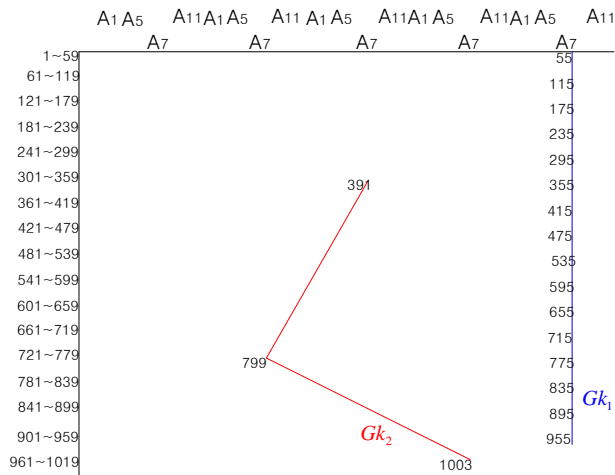

3.13 $(12x+1)(12y+11), (Gm_n)$

×	13	25	37	49	61	73	85	97
11	143							
23	299	575						
35	455	875	1295					
47	611	1175	1739	2303				
59	767	1475	2183	2891	3599			
71	923	1775	2627	3479	4331	5183		
83	1079	2075	3071	4067	5063	6059	7055	
95	1235	2375	3515	4655	5795	6935	8075	9215

- $Gm_1: 143(a_1)$ $299(a_2)$ $455(a_3)$ $611(a_4)$ $767(a_5)$ $923(a_6)$ $1079(a_7)$ $1235(a_8)$
 $Gm_2: 575(a_1)$ $875(a_2)$ $1175(a_3)$ $1475(a_4)$ $1775(a_5)$ $2075(a_6)$ $2375(a_7)$
 $Gm_3: 1295(a_1)$ $1739(a_2)$ $2183(a_3)$ $2627(a_4)$ $3071(a_5)$ $3515(a_6)$
 $Gm_4: 2303(a_1)$ $2891(a_2)$ $3479(a_3)$ $4067(a_4)$ $4655(a_5)$
 $Gm_5: 3599(a_1)$ $4331(a_2)$ $5063(a_3)$ $5795(a_4)$
 $Gm_6: 5183(a_1)$ $6059(a_2)$ $6935(a_3)$
 $Gm_7: 7055(a_1)$ $8075(a_2)$
 $Gm_8: 9215(a_1)$

- $Gm_1: a_1 = (12x+1)(12y+11) = 143, \quad d = 12 \times (12x+1) = 156(x=1, y=0)$
 $Gm_2: a_1 = (12x+1)(12y+11) = 575, \quad d = 12 \times (12x+1) = 300(x=2, y=1)$
 $Gm_3: a_1 = (12x+1)(12y+11) = 1295, \quad d = 12 \times (12x+1) = 444(x=3, y=2)$
 $Gm_4: a_1 = (12x+1)(12y+11) = 2303, \quad d = 12 \times (12x+1) = 588(x=4, y=3)$
 $Gm_5: a_1 = (12x+1)(12y+11) = 3599, \quad d = 12 \times (12x+1) = 732(x=5, y=4)$
 $Gm_6: a_1 = (12x+1)(12y+11) = 5183, \quad d = 12 \times (12x+1) = 876(x=6, y=5)$
 $Gm_7: a_1 = (12x+1)(12y+11) = 7055, \quad d = 12 \times (12x+1) = 1020(x=7, y=6)$
 $Gm_8: a_1 = (12x+1)(12y+11) = 9215, \quad d = 12 \times (12x+1) = 1164(x=8, y=7)$
 \vdots
 $Gm_n: a_1 = (12x+1)(12y+11) = 144xy + 132x + 12y + 11, \quad d = 12 \times (12x+1)(x=n, y=n-1)$

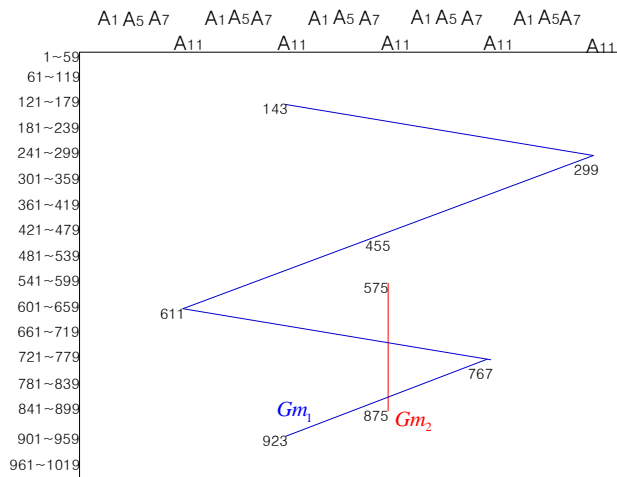

3.14 $(12x+11)(12y+1), (Gn_n)$

×	11	23	35	47	59	71	83	95
13	143							
25	275	575						
37	407	851	1295					
49	539	1127	1715	2303				
61	671	1403	2135	2867	3599			
73	803	1679	2555	3431	4307	5183		
85	935	1955	2975	3995	5015	6035	7055	
97	1067	2231	3395	4559	5723	6887	8051	9215

- $Gn_1: 143(a_1)$ $275(a_2)$ $407(a_3)$ $539(a_4)$ $671(a_5)$ $803(a_6)$ $935(a_7)$ $1067(a_8)$
 $Gn_2: 575(a_1)$ $851(a_2)$ $1127(a_3)$ $1403(a_4)$ $1679(a_5)$ $1955(a_6)$ $2231(a_7)$
 $Gn_3: 1295(a_1)$ $1715(a_2)$ $2135(a_3)$ $2555(a_4)$ $2975(a_5)$ $3395(a_6)$
 $Gn_4: 2303(a_1)$ $2867(a_2)$ $3431(a_3)$ $3995(a_4)$ $4559(a_5)$
 $Gn_5: 3599(a_1)$ $4307(a_2)$ $5015(a_3)$ $5723(a_4)$
 $Gn_6: 5183(a_1)$ $6035(a_2)$ $6887(a_3)$
 $Gn_7: 7055(a_1)$ $8051(a_2)$
 $Gn_8: 9215(a_1)$

- $Gn_1: a_1 = (12x+11)(12y+1) = 143, \quad d = 12 \times (12x+11) = 132 (x=0, y=1)$
 $Gn_2: a_1 = (12x+11)(12y+1) = 575, \quad d = 12 \times (12x+11) = 276 (x=1, y=2)$
 $Gn_3: a_1 = (12x+11)(12y+1) = 1295, \quad d = 12 \times (12x+11) = 420 (x=2, y=3)$
 $Gn_4: a_1 = (12x+11)(12y+1) = 2303, \quad d = 12 \times (12x+11) = 564 (x=3, y=4)$
 $Gn_5: a_1 = (12x+11)(12y+1) = 3599, \quad d = 12 \times (12x+11) = 708 (x=4, y=5)$
 $Gn_6: a_1 = (12x+11)(12y+1) = 5183, \quad d = 12 \times (12x+11) = 852 (x=5, y=6)$
 $Gn_7: a_1 = (12x+11)(12y+1) = 7055, \quad d = 12 \times (12x+11) = 996 (x=6, y=7)$
 $Gn_8: a_1 = (12x+11)(12y+1) = 9215, \quad d = 12 \times (12x+11) = 1140 (x=7, y=8)$
 \vdots
 $Gn_n: a_1 = (12x+11)(12y+1) = 144xy + 12x + 132y + 11, \quad d = 12 \times (12x+11) (x=n-1, y=n)$

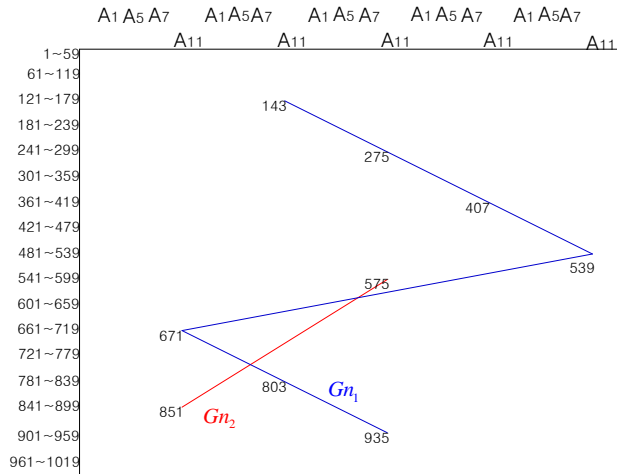

3.15 $(12x + 5)(12y + 7), (Go_n)$

×	5	17	29	41	53	65	77	89
7	35							
19	95	323						
31	155	527	899					
43	215	731	1247	1763				
55	275	935	1595	2255	2915			
67	335	1139	1943	2747	3551	4355		
79	395	1343	2291	3239	4187	5135	6083	
91	455	1547	2639	3731	4823	5915	7007	8099

- $Go_1: 35(a_1) \quad 95(a_2) \quad 155(a_3) \quad 215(a_4) \quad 275(a_5) \quad 335(a_6) \quad 395(a_7) \quad 455(a_8)$
 $Go_2: 323(a_1) \quad 527(a_2) \quad 731(a_3) \quad 935(a_4) \quad 1139(a_5) \quad 1343(a_6) \quad 1547(a_7)$
 $Go_3: 899(a_1) \quad 1247(a_2) \quad 1595(a_3) \quad 1943(a_4) \quad 2291(a_5) \quad 2639(a_6)$
 $Go_4: 1763(a_1) \quad 2255(a_2) \quad 2747(a_3) \quad 3239(a_4) \quad 3731(a_5)$
 $Go_5: 2915(a_1) \quad 3551(a_2) \quad 4187(a_3) \quad 4823(a_4)$
 $Go_6: 4355(a_1) \quad 5135(a_2) \quad 5915(a_3)$
 $Go_7: 6083(a_1) \quad 7007(a_2)$
 $Go_8: 8099(a_1)$

- $Go_1: a_1 = (12x + 5)(12y + 7) = 35, \quad d = 12 \times (12x + 5) = 60 (x = 0, y = 0)$
 $Go_2: a_1 = (12x + 5)(12y + 7) = 323, \quad d = 12 \times (12x + 5) = 204 (x = 1, y = 1)$
 $Go_3: a_1 = (12x + 5)(12y + 7) = 899, \quad d = 12 \times (12x + 5) = 348 (x = 2, y = 2)$
 $Go_4: a_1 = (12x + 5)(12y + 7) = 1763, \quad d = 12 \times (12x + 5) = 492 (x = 3, y = 3)$
 $Go_5: a_1 = (12x + 5)(12y + 7) = 2915, \quad d = 12 \times (12x + 5) = 636 (x = 4, y = 4)$
 $Go_6: a_1 = (12x + 5)(12y + 7) = 4355, \quad d = 12 \times (12x + 5) = 780 (x = 5, y = 5)$
 $Go_7: a_1 = (12x + 5)(12y + 7) = 6083, \quad d = 12 \times (12x + 5) = 924 (x = 6, y = 6)$
 $Go_8: a_1 = (12x + 5)(12y + 7) = 8099, \quad d = 12 \times (12x + 5) = 1068 (x = 7, y = 7)$
 \vdots
 $Go_n: a_1 = (12x + 5)(12y + 7) = 144xy + 84x + 60y + 35, \quad d = 12 \times (12x + 5) (x = n - 1, y = n - 1)$

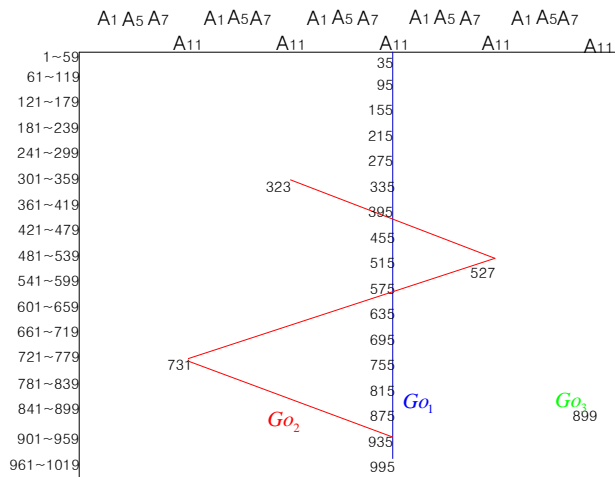

3.16 $(12x+7)(12y+5), (Gp_n)$

×	7	19	31	43	55	67	79	91
5	35							
17	119	323						
29	203	551	899					
41	287	779	1271	1763				
53	371	1007	1643	2279	2915			
65	455	1235	2015	2795	3575	4355		
77	539	1463	2387	3311	4235	5159	6083	
89	623	1691	2759	3827	4895	5963	7031	8099

- $\Phi_1: 35(a_1) \quad 119(a_2) \quad 203(a_3) \quad 287(a_4) \quad 371(a_5) \quad 455(a_6) \quad 539(a_7) \quad 623(a_8)$
- $\Phi_2: 323(a_1) \quad 551(a_2) \quad 779(a_3) \quad 1007(a_4) \quad 1235(a_5) \quad 1463(a_6) \quad 1691(a_7)$
- $\Phi_3: 899(a_1) \quad 1271(a_2) \quad 1643(a_3) \quad 2015(a_4) \quad 2387(a_5) \quad 2759(a_6)$
- $\Phi_4: 1763(a_1) \quad 2279(a_2) \quad 2795(a_3) \quad 3311(a_4) \quad 3827(a_5)$
- $\Phi_5: 2915(a_1) \quad 3575(a_2) \quad 4235(a_3) \quad 4895(a_4)$
- $\Phi_6: 4355(a_1) \quad 5159(a_2) \quad 5963(a_3)$
- $\Phi_7: 6083(a_1) \quad 7031(a_2)$
- $\Phi_8: 8099(a_1)$

- $\Phi_1: a_1 = (12x+7)(12y+5) = 35, \quad d = 12 \times (12x+7) = 84(x=0, y=0)$
- $\Phi_2: a_1 = (12x+7)(12y+5) = 323, \quad d = 12 \times (12x+7) = 228(x=1, y=1)$
- $\Phi_3: a_1 = (12x+7)(12y+5) = 899, \quad d = 12 \times (12x+7) = 372(x=2, y=2)$
- $\Phi_4: a_1 = (12x+7)(12y+5) = 1763, \quad d = 12 \times (12x+7) = 516(x=3, y=3)$
- $\Phi_5: a_1 = (12x+7)(12y+5) = 2915, \quad d = 12 \times (12x+7) = 660(x=4, y=4)$
- $\Phi_6: a_1 = (12x+7)(12y+5) = 4355, \quad d = 12 \times (12x+7) = 804(x=5, y=5)$
- $\Phi_7: a_1 = (12x+7)(12y+5) = 6083, \quad d = 12 \times (12x+7) = 948(x=6, y=6)$
- $\Phi_8: a_1 = (12x+7)(12y+5) = 8099, \quad d = 12 \times (12x+7) = 1092(x=7, y=7)$
- ⋮
- $\Phi_n: a_1 = (12x+7)(12y+5) = 144xy + 60x + 84y + 35, \quad d = 12 \times (12x+7)(x=n-1, y=n-1)$

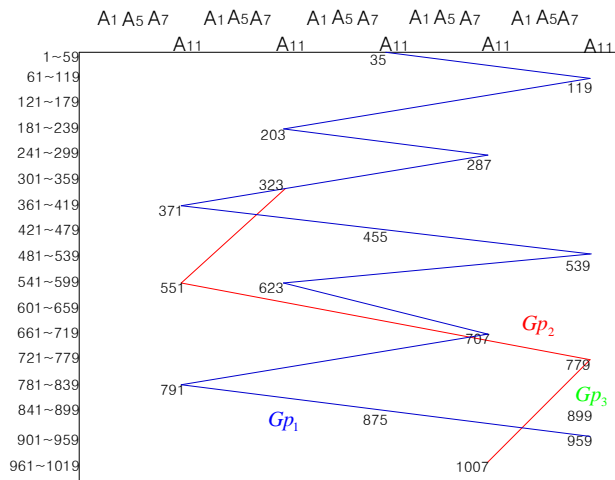

4. Primality Test

We have seen that all the composite numbers but 2 and 3 can be represented in a form of $(12x + \alpha) \times (12y + \beta)$. Then, how can we determine if a given positive integer, G , is prime or composite?

Let G be an arbitrary positive integer.

- i) Check if G is a multiple of 2 or 3. If G is a multiple of one of these, it is a composite number.
- ii) If G is not a multiple of 2 or 3, G 's remainder R when divided by 12 is $R \in \{1, 5, 7, 11\}$ and R is the a number in the table multiplication elements, then G is a composite number. If R is not the same as any of the multiplication elements, then G is a prime number.

4.1 Substitution.

If a given number, G , is not a multiple of 2 or 3, we can express it as follows.

$$\begin{aligned} G &= (12x + \alpha) \times (12y + \beta) \\ &= 144xy + 12\beta x + 12\alpha y + \alpha\beta (\alpha, \beta \in \{1, 5, 7, 11\}) \end{aligned}$$

If we substitute xy , $\beta x + \alpha y$ with X and Y , respectively,

$$\square \beta x + \alpha y = Y, \quad xy = X$$

The result is the following.

$$\begin{aligned} \square (12x + \alpha) \times (12y + \beta) \\ &= 144X + 12Y + \alpha\beta = G (G \text{ is given number}) \\ &= 12X + Y = C \quad (C = \frac{G - \alpha\beta}{12}) \end{aligned}$$

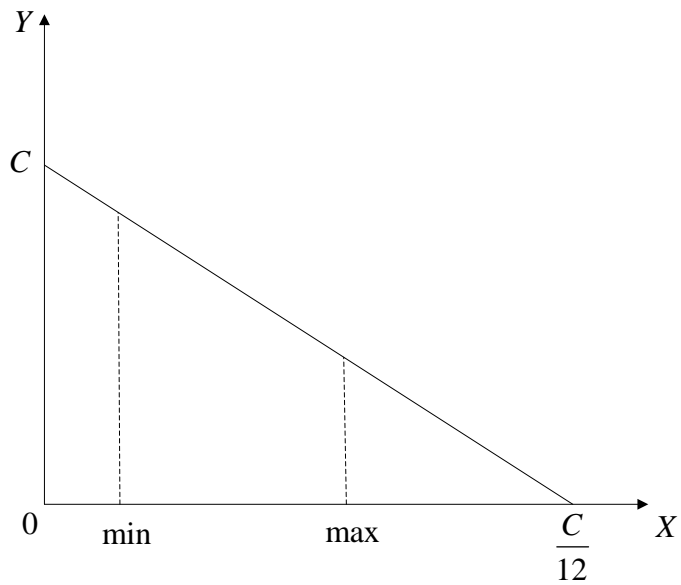

4.2 Determination of a valid domain.

Let us apply the arithmetic mean and geometric mean to xy and $\beta x + \alpha y$.

From $\beta x + \alpha y = Y$ and $xy = X$, $y = \frac{-\beta x + Y}{\alpha}$.

x	y	$X(xy)$
1	$\frac{-\beta+Y}{\alpha}$	$\frac{-\beta+Y}{\alpha} \times 1$
2	$\frac{-2 \cdot \beta+Y}{\alpha}$	$\frac{-2 \cdot \beta+Y}{\alpha} \times 2$
3	$\frac{-3 \cdot \beta+Y}{\alpha}$	$\frac{-3 \cdot \beta+Y}{\alpha} \times 3$
4	$\frac{-4 \cdot \beta+Y}{\alpha}$	$\frac{-4 \cdot \beta+Y}{\alpha} \times 4$
5	$\frac{-5 \cdot \beta+Y}{\alpha}$	$\frac{-5 \cdot \beta+Y}{\alpha} \times 5$
\vdots	\vdots	\vdots
k	$\frac{-k \cdot \beta+Y}{\alpha}$	$\frac{-k \cdot \beta+Y}{\alpha} \times k$

When $x=1$, $X(xy)$ is the minimum. Therefore, the minimum of $X(xy)$ is

$$X(xy) = \frac{-\beta+Y}{\alpha}.$$

$$12X + Y = C$$

$$\rightarrow 12X + \alpha \cdot X + \beta = C \text{ (substitution : } Y = \alpha \cdot X + \beta \text{)}$$

$$\rightarrow (12 + \alpha) \cdot X = C - \beta$$

$$\rightarrow X = \frac{C - \beta}{12 + \alpha}$$

The maximum of $X(xy)$ is

(i) If $x+y$ is even, then the maximum is achieved when $x = y$.

$$12X + Y = C$$

$$\rightarrow 12x^2 + (\alpha + \beta) \cdot x - C = 0$$

$$\rightarrow x = \frac{-(\alpha + \beta) \pm \sqrt{(\alpha + \beta)^2 + 4 \cdot 12 \cdot C}}{24}$$

$$\rightarrow X(xy, x = y) = \left(\frac{-(\alpha + \beta) \pm \sqrt{(\alpha + \beta)^2 + 4 \cdot 12 \cdot C}}{24} \right)^2$$

$$\rightarrow X(\text{positive}) = \left(\frac{-(\alpha + \beta) + \sqrt{(\alpha + \beta)^2 + 4 \cdot 12 \cdot C}}{24} \right)^2$$

(ii) If $x + y$ is odd, then the maximum is achieved when $x + 1 = y$.

$$12X + Y = C$$

$$\rightarrow 12x(x+1) + \beta \cdot x + \alpha(x+1) - C = 0$$

$$\rightarrow 12x^2 + (\alpha + \beta + 12)x + \alpha - C = 0$$

$$\rightarrow x = \frac{-(\alpha + \beta + 12) \pm \sqrt{(\alpha + \beta + 12)^2 + 4 \cdot 12 \cdot (C - \alpha)}}{24}$$

$$\rightarrow X(\text{positive}) = \left(\frac{-(\alpha + \beta + 12) + \sqrt{(\alpha + \beta + 12)^2 + 4 \cdot 12 \cdot (C - \alpha)}}{24} \right)^2$$

- If the maximum and minimum of $X(xy)$ is not an integer, then we can make it an integer by rounding it up.

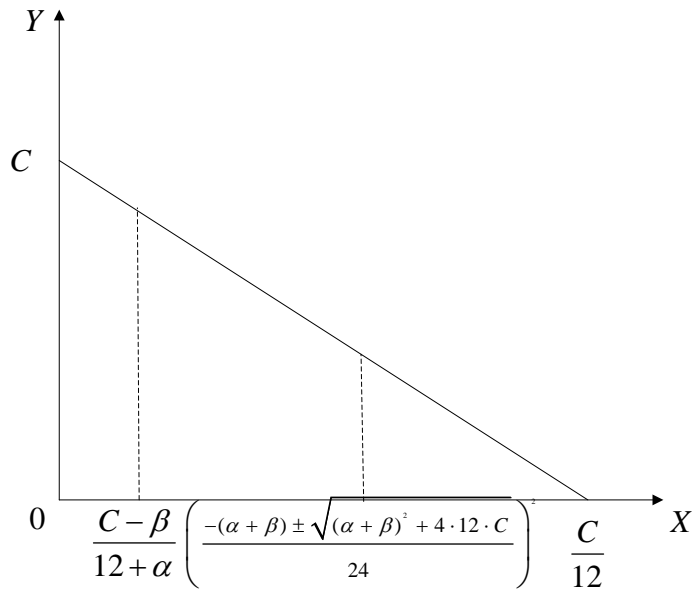

4.3 Finding integer values of x and y .

If we can determine the valid domain, we can make the following table list of (X, Y) .

X	a_1	a_2	a_3	a_4	a_5	a_6	\dots	\dots	a_n
Y	b_1	b_2	b_3	b_4	b_5	b_6	\dots	\dots	b_n

In $12X + Y = C$, X increases by 1 and Y decreases by 12. So, X and Y have properties of an arithmetic progression. Let two arithmetic progressions, X and Y , be $X = n + a$ and $Y = -12n + b$, respectively.

(X, Y) Tables pairs

Is there an efficient method to find a valid set of (X, Y) , which has an integer root, from $(a_1, b_1), (a_2, b_2), (a_3, b_3), (a_4, b_4), (a_5, b_5), (a_6, b_6), \dots, (a_n, b_n)$.

4.3.1 First Method- Pell's equation

x, n, r is positive integer (x, r contains zero)

$$\text{Since } X = \frac{-\beta \cdot x^2 + Y \cdot x}{\alpha}$$

$$n+a = \frac{-\beta \cdot x^2 + (-12n+b) \cdot x}{\alpha}, (\text{substitution : } X = n+a, Y = -12n+b)$$

$$\rightarrow \alpha \cdot (n+a) = -\beta \cdot x^2 + (-12n+b) \cdot x$$

$$\rightarrow \beta \cdot x^2 - (b-12n) \cdot x + \alpha \cdot (n+a) = 0$$

$$\rightarrow x = \frac{(b-12n) \pm \sqrt{(b-12n)^2 - 4 \cdot \alpha \beta \cdot (n+a)}}{2 \cdot \beta}$$

Since x is zero or a positive integer

We can find integer roots (n, r) from $r^2 = (b-12n)^2 - 4 \cdot \alpha \beta \cdot (n+a)$

$$\rightarrow 36r^2 = 36 \cdot \{(12n-b)^2 - 4 \cdot \alpha \beta \cdot (n+a)\}$$

$$\rightarrow 36r^2 = 36 \cdot (144n^2 - 24b \cdot n + b^2 - 4 \cdot \alpha \beta \cdot n - 4 \cdot \alpha \beta \cdot a)$$

$$\rightarrow 36r^2 = 36 \cdot (144n^2 - 24b \cdot n - 4 \cdot \alpha \beta \cdot n + b^2 - 4 \cdot \alpha \beta \cdot a)$$

$$\rightarrow 36r^2 = (72n - (6b + \alpha\beta))^2 - (6b + \alpha\beta)^2 + 36b^2 - 4 \cdot 36 \cdot \alpha\beta \cdot a$$

$$\rightarrow (72n - (6b + \alpha\beta))^2 - 36r^2 = (6b + \alpha\beta)^2 - 36b^2 + 4 \cdot 36 \cdot \alpha\beta \cdot a$$

$$\rightarrow (72n - (6b + \alpha\beta) + 6r) \times (72n - (6b + \alpha\beta) - 6r) = 12(12a + b) \cdot \alpha\beta + (\alpha\beta)^2$$

If an integer root, (n, r) , exists, then we can find integer (x, y) .

Example)

Let the given number $G = 32,185$.

From $G = 2,682 \times 12 + 1$, $R = 1$. Since it is included in A_1 , we can perform the following table multiplications. $A_1 \times A_1$, $A_3 \times A_3$, $A_7 \times A_7$, $A_{11} \times A_{11}$

When $\alpha = \beta = 1$, $G = (12x + 1) \times (12y + 1)$ (This paper will deal with only one example.)

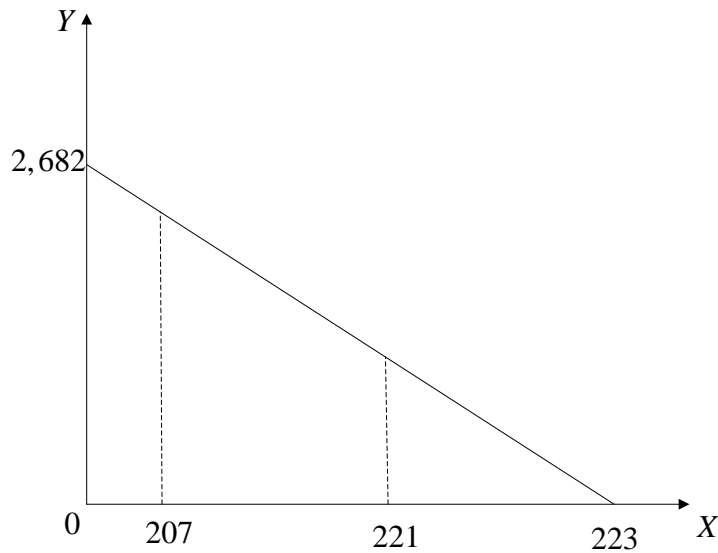

X	207	208	209	210	211	212	221
Y	198	186	174	162	150	138	30

$$X = 207 + n - 1 = n + 206, \quad Y = 198 - 12(n - 1) = -12n + 210$$

$$\rightarrow a = 206, \quad b = 210, \quad \alpha\beta = 1$$

$$r^2 = (12n - b)^2 - 4 \cdot \alpha\beta \cdot (n + a)$$

$$r^2 = (12n - 210)^2 - 4 \cdot (n + 206)$$

$$\rightarrow r^2 = 144n^2 - 5,044n + 43,276 = 38,376 - \sum_{k=1}^{n-1} (4,612 - 288(k-1))$$

$$\rightarrow 36(144n^2 - 5,044n + 43,276) = 36r^2$$

$$\rightarrow (72n - 1261)^2 - 32,185 = 36r^2$$

$$\rightarrow (72n - 1261)^2 - 36r^2 = 32,185$$

$$\rightarrow (72n - 1,261 - 6r) \times (72n - 1,261 + 6r) = (\pm 1, \pm 32,185), (\pm 5, \pm 6,437), (\pm 41, \pm 785), (\pm 157, \pm 205)$$

The pair that has an integer value is $(-157, -205)$

$$\rightarrow (72n - 1,261 - 6r) \times (72n - 1,261 + 6r) = (-157, -205)$$

The integer roots are $(n, r) = (15, 4)$.

4.3.2 Second Method

In order to find (x, n) pairs that have integer roots, let us do the substitutions

$$\beta x + \alpha y = Y, \quad xy = X$$

$$x, y = \frac{Y - \beta \cdot x}{\alpha}$$

$$\rightarrow X = \frac{-\beta \cdot x^2 + Y \cdot x}{\alpha},$$

$$\rightarrow n + a = \frac{-\beta \cdot x^2 + (-12n + b) \cdot x}{\alpha}, \text{ (substitution : } X = n + a, Y = -12n + b)$$

$$\rightarrow (12x + \alpha)n = -\beta \cdot x^2 + b \cdot x - \alpha \cdot a,$$

$$\rightarrow n = \frac{-\beta \cdot x^2 + b \cdot x - \alpha \cdot a}{12x + \alpha}$$

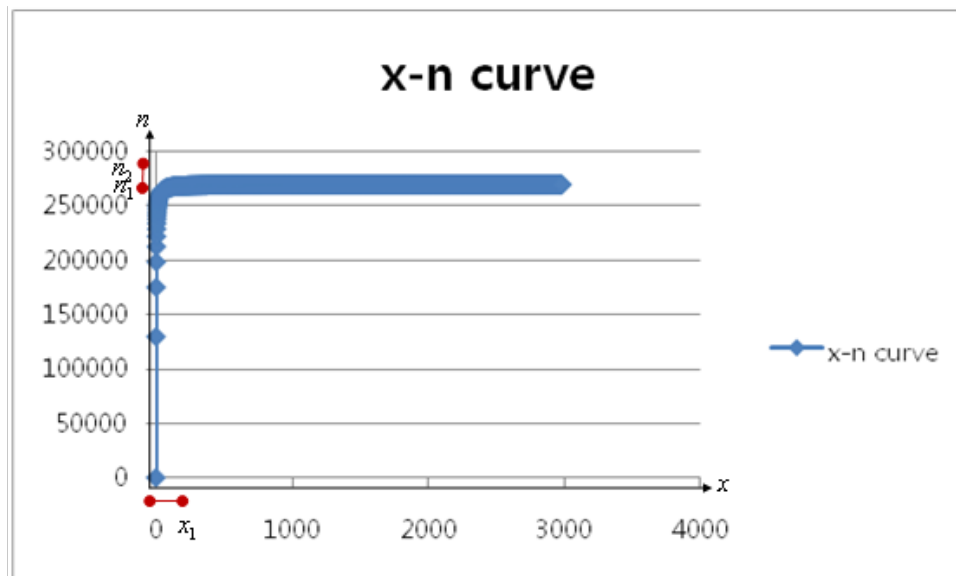

$n - x$ Curve has the shape of a long sickle.

In order to find an integer root pair, (x, n) , 270 thousand iteration is required. But, this method is inefficient because all (x, Y) tables need to be iterated. However, from the graph of the function, we can discover the following properties. When the value of x is small, n increases faster. However, for a certain domain, the rate at which n increases is greatly reduced as x increases, and when n approaches its limit, n does not either increase or decrease as x increases. Therefore, we can confirm that the values of n congregate at certain domains.

So, we have come up with the following idea to find integer root pair (x, n) .

If we do the iteration in the domain $0 \sim x_1$, on the x-axis (up to the point where $n_{k+1} - n_k$ is greater than 1) and in the range $n_1 \sim n_2$, on the n-axis at the points where $n_{k+1} - n_k$ becomes less than 1, then we have the same effect as that of inspecting all the whole numbers.

Therefore, the number of iterations becomes $H = (0 \sim x_1) + (n_1 \sim n_2)$.

But, we have to multiply by 4 because it is hard to find the value of G from the 16 subgroups (the greater the value of G , the more the computational complexity increases) (Each of A1, A5, A7, and A11 has 4 subgroups.)

Total number of iterations $H_{total} = 4 \times H$

Example)

Let the given number be $G = 32,185$. (the same as in the previous example)

X	207	208	209	210	211	212	221
Y	198	186	174	162	150	138	30

$$X = 207 + n - 1 = n + 206, \quad Y = 198 - 12(n - 1) = -12n + 210$$

When $\rightarrow a = 206, b = 210, \alpha\beta = 1,$

$$\text{from } n = \frac{-\beta \cdot x^2 + b \cdot x - \alpha \cdot a}{12x + \alpha}, \text{ ,n becomes } n = \frac{-x^2 + 210 \cdot x - 206}{12x + 1}.$$

x	1	2	3	4	5	6	13
n	0.23	8.4	11.21	12.61	13.42	13.94	15

In the A domain, the values of x are such that $x_n - x_{n-1} \geq 1$. So, we count by x .

In the B domain, the values of x are such that $x_n - x_{n-1} \leq 1$. So, we count by n .

In the A domain, the number of x count is, 5 (1, 2, 3, 4, 5) and, in the B domain, that of n count is 2 (14, 15). So, $H = 5 + 2 = 7$

When $G = 505,488,001$, $H = 800$ approximately. When $G = 5,391,508,801$, $H = 2,700$ approximately.

So, $H = O\left(\frac{\sqrt{x}}{20}\right)$, approximately.

5. Uncertainty Principle

Given a number G , how can we be sure that it is prime or composite? If it is a composite number, it must, of course, exist on the multiplication table. If it is a prime number, it must not exist on the multiplication table.

From $G = (12x + \alpha) \times (12y + \beta)$, it is thought to be very easy to find positive integers, x and y , given a composite number, G . However, the coordinates of the matrix can go to infinity. When G is a very large number, it is not easy to find positive integers for x and y . In the worst case, we have to inspect the whole matrix. We can recognize that it is impossible to assign arbitrary integers to get positive integers for x and y . In other words, if we can determine the value of the positive integer x , we cannot find the value of y (which turns out to be a real or complex number). On the other hand, if we can determine the value of positive integer y , we cannot find the value of x (which turns out to be real or complex number).

If G is a composite number, the positive integer values x and y , are determined independent of ourselves and we, as observers, are unable to find the values until we do the necessary calculation.

6. Impossibility Principle

From $G = (12x + \alpha) \times (12y + \beta)$, can we find the values of x and y , simultaneously? It was once thought that there was a method to find them intuitively, but this was a fantasy or phantom. It is impossible. The principle is very simple.

If a given number, G , exists on the matrix, then it is a composite number. If not, then it is a prime number. If G exists on the matrix (a composite number), then it is represented as $G = (12x + \alpha) \times (12y + \beta)$. Also, the matrix is structured in arithmetic progression groups. So, the composite number G , an element of matrix, is an element of an arithmetic progression. Therefore, we can express it as follows.

$$G = a_1 + (n-1)d$$

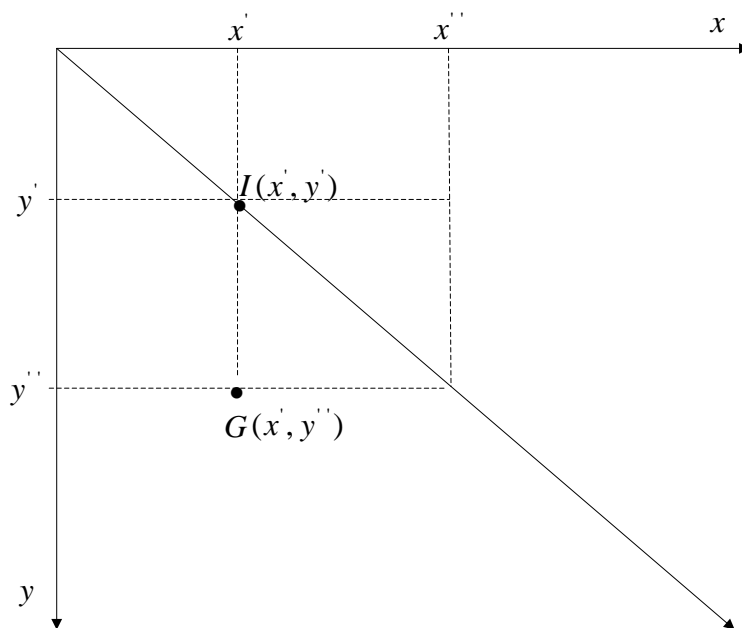

Since IG is an arithmetic progression, element G can be expressed as $G = I + (n-1)d$.

$$I = (12x' + \alpha) \times (12y' + \beta), \text{ (first term)}$$

$$d = 12 \times (12x' + \alpha), \text{ (common difference)}$$

$$n = y'' - y' + 1, (n = 1, 2, 3, 4, \dots)$$

So, after some manipulation,

$$G = I + (n-1)d$$

$$\rightarrow (12x' + \alpha) \cdot (12y' + \beta) + (y'' - y') \cdot (12 \times (12x' + \alpha))$$

$$\rightarrow (144x'y' + 12 \cdot \beta \cdot x' + 12 \cdot \alpha \cdot y' + \alpha\beta) + (144x'y'' + 12 \cdot \alpha \cdot y'' - 144x'y' - 12 \cdot \alpha \cdot y')$$

$$\rightarrow 144x'y'' + 12 \cdot \beta \cdot x' + 12 \cdot \alpha \cdot y'' + \alpha\beta$$

$$\rightarrow (12x' + \alpha)(12y'' + \beta)$$

When G is given, we can see that it is equivalent to the problem of finding positive integers x and y . Given I , n , and d , it is easy to find the value of G . However, is it easy to find the value of I , n , and d once we are given the value of G ? It is not easy. Determining if a given number is a prime or a composite is the same as finding the initial term, difference, and general term of G , an element of arithmetic progression. Is it possible? No, it isn't.

7. Conclusion

This paper asserts that the composite numbers of the $12n+1, 5, 7, 11$ series make up sixteen arithmetic progression groups. We were able indirectly to deduce the uncertainty of prime numbers through the composite numbers. It is true that, unlike the prime numbers, the composite numbers are governed by a rule that is structural and regular. Using the matrix, we have shown it possible to significantly reduce perceptive complexity of Pseudoprimes (composite numbers of the $12n+1, 5, 7, 11$ and, at the same time, to express them in quadratic algebra. Applying arithmetic and geometric means, we reduced some of the computational complexity by converting the matrix into a quadratic equation and computing the valid domains. But, the uncertainty of the matrix directly reflects the irregularity of prime numbers (whether a given number is a prime number or a composite number and what the next prime number is). We can see that, since the complexity of a matrix as a given number, G , becomes larger and larger, it becomes harder to predict the next prime number. Then, is there a method to reduce the complexity of the matrix? It is impossible. To find the given number, we need to solve $G = (12x + \alpha) \times (12y + \beta)$. Since G is an element of the arithmetic progression, $G = a_1 + (n-1)d$

, ($a_1 = \text{first term}$, $d = \text{common difference}$), it is the same problem as finding the initial term, common difference from a given number, G . Is this possible? It is not possible.

Acknowledgements

I am very grateful to Professor Youn, cheong and to Lim, sang-tae for their advice and for the patience they showed, assisting me.

8. Reference

- [1] David M. Burton, Elementary Number Theory, McGraw Hill India; Sixth edition (September 27, 2005), pages 39-50
- [2] G. H. Hardy, An Introduction to the Theory of Numbers, Publisher: Oxford University Press, USA; 6 edition (September 15, 2008), pages 17-21
- [3] H. E. Rose, A Course in Number Theory, Oxford University Press, USA; 2 edition (December 14, 1995), pages 237-245
- [4] Richard K. Guy, Unsolved Problems in Number Theory (Problem Books in Mathematics, Springer; 3rd edition (July 13, 2004), pages 3-5
- [5] David Bressoud, A Course in Computational Number Theory (Key Curriculum Press), Wiley (June 10, 2008), pages 97-143
- [6] G. H. Hardy, An Introduction to the Theory of Numbers, Oxford University Press, USA; 6 edition (September 15, 2008), pages 14-16
- [7] Hans Riesel, Prime Numbers and Computer Methods for Factorization (Progress in Mathematics), Birkhauser Boston; 2nd edition(October 1, 1994), pages 6-9
- [8] Marcus Du Sautoy, The Music of the Primes, Harper Perennial (April 27, 2004), pages 3-5
- [9] John Derbyshire, Prime Obsession, Plume (May 25, 2004), pages 32-47
- [10] H. Davenport, The Higher Arithmetic: An Introduction to the Theory of Numbers, Cambridge University Press; 8 edition (November 17, 2008), Page at 1-9
- [11] Phillip J. Davis, The Mathematical Experience, Mariner Books (January 14, 1999), pages 209-214
- [12] Tom M. Apostol, Introduction to Analytic Number Theory (Undergraduate Texts in Mathematics), Springer; 1ST edition (May 11, 1976), pages 14-16, 146-155
- [13] Gareth A. Jones , Elementary Number Theory, Springer; Corrected edition (January 14, 1998), pages 19-35

[Arithmetic Progression]

[14] B. Green and T. Tao, The primes contain arbitrarily long arithmetic progressions, preprint at arXiv:math/0404188

[15] T. Tao, The dichotomy between structure and randomness, arithmetic progressions, and the primes, arXiv:math/0512114v2

[16] B. Green, Long arithmetic progressions of primes, arXiv:math/0508063

[17] T. Tao, Obstructions to uniformity, and arithmetic patterns in the primes, arXiv:math/0505402

[18] T. Tao, The dichotomy between structure and randomness, arithmetic progressions, and the primes, arXiv:math/0512114

[19] T. Tao, Arithmetic progressions and the primes - El Escorial lectures, arXiv:math/0411246

[20] T. Tao, Linear Equations in Primes, arXiv:math/0606088

[21] T. Tao, Structure and randomness in the prime numbers, a small selection of results in number theory, Science colloquium January 17, 2007

[22] T. Tao, What is good mathematics?, arXiv:math/0702396

[23] E. Szemerédi, On sets of integers containing no k elements in arithmetic progression, Acta Arithmetica XXVII(1975)

[24] B. Kra, *The Green-Tao Theorem on arithmetic progressions in the primes: an ergodic point of view*, preprint.

[25] H. Dubner, T. Forbes, N. Lygeros, M. Mizony, H. Nelson, P. Zimmermann, Ten Consecutive primes in arithmetic progression, Math. Comp. 71 (2002), 1323-1328.

[26] J. Pintz, Are there arbitrarily long arithmetic progressions in the sequence of twin primes?, preprint at arXiv:1002.2899

[27] Andrei V. Vityazev, Galina V. Pechernikova, Structure of the Prime Distribution within the Sequence of Natural Numbers, preprint at arXiv:math/0609797

[28] Paulo R. A. Campos*, Viviane M. de Oliveira, Ronaldo Giro, and Douglas S. Galvão, Emergence of Prime Numbers as the Result of Evolutionary Strategy, Phys. Rev. Lett. 93, 098107 (2004) [4 pages]

- [29] G.Tenenbaum, M. Mendès France, The prime numbers and their distribution, American Mathematical Society (May 2000), Pages at 52-60
- [30] H. Davenport, Multiplicative Number Theory, Springer; 3rd edition (October 31, 2000), Pages 1-27
- [31] Atkin, A. O. L. and Bernstein, D. J. Prime sieves using binary quadratic forms, Math. Comp. 73 (2004), 1023-1030
- [32] R. Crandal 1 and C. Pomerance , Prime Number(A Computational Perspective), Springer; 2nd edition (August 4, 2005), Pages at 121-156
- [33] A. E. Ingham, The distribution of prime numbers, Cambridge University Press (September 28, 1990), Page at 9-40, 86-107
- [34] J. Barkley Rosser and Lowell Schoenfeld, Approximate formulas for some functions of prime numbers, Illinois J. Math. Volume 6, Issue 1 (1962), 64-94.
- [35] Harold N. Shapiro, On Prime in arithmetic progression, Annals of Mathematics, April 26, 1949
- [36] W. NarKiewicz, The Development of Prime Number Theory, Springer; 1 edition (May 25, 2000), pages at 49-93
- [37] Atle Selberg, An Elementary Proof of Dirichlet's Theorem About Primes in an Arithmetic Progression, Annals of Mathematics 1949, pages at 297
- [38] G.H. Hardy, The General Theory Of Dirichlets Series, Book Jungle (June 8, 2009)

External links

- [39] http://en.wikipedia.org/wiki/Primes_in_arithmetic_progression
- [40] http://en.wikipedia.org/wiki/Sieve_of_Eratosthenes
- [41] http://en.wikipedia.org/wiki/Modular_Arithmetic
- [42] http://mersennewiki.org/index.php/Modular_arithmetic
- [43] <http://www.cut-the-knot.org/blue/Modulo.shtml>
- [44] <http://en.wikipedia.org/wiki/Remainder>
- [45] In this [modular art](#) article, one can learn more about applications of modular arithmetic in art.
- [46] [Modular Arithmetic and patterns in addition and multiplication tables](#)
- [47] Weisstein, Eric W., "[Modular Arithmetic](#) " from MathWorld.

<Appendix 1> Certainty of Mathematics

(a) Platonism and Mathematical Reality

According to Platonism, mathematical objects are real. Their existence is an objective fact, quite independent of our knowledge of them. These objects are, of course, not physical or material. They exist outside the space and time of physical existence. They are immutable they were not created, and they will not change or disappear. Any meaningful question about a mathematical object has a definite answer, whether we are able to determine it or not. According to Platonism, a mathematician is an empirical scientist like a geologist; he cannot invent anything, because it is all there already. All he can do is discover. (The Mathematical Experience, 318)

Since mathematical objects are what they are, in defiance of our ignorance or preferences, they must be real in a sense independent of human minds. (The Mathematical Experience, 408)

The Later Pythagoreans and the Platonists distinguished sharply between the world of things and the world of ideas. Objects and relationships in the material world were subject to imperfections, change, and decay and hence did not represent the ultimate truth, but there was an ideal world in which there were absolute and unchanging truths. (The Loss of Certainty, 16)

The roots of the philosophy of mathematics, as of mathematics itself, are in classical Greece. For the Greeks, mathematics meant geometry, and the philosophy of mathematics in Plato and Aristotle is the philosophy of geometry. For Plato, the mission of philosophy was to discover true knowledge behind the veil of opinion and appearance, the change and illusion of the temporal world. (The Mathematical Experience, 325)

(b) Debacle of Certainty

A classic statement to this effect was made by Pascal(1623~1662) in his *Pensees* long before the modern controversies arose. "Truth is so subtle a point that our instruments are too blunt to touch it exactly. When they do reach it, they crush the point and bear down around it , more on the false than on the true." (The Loss of Certainty, 324)

Certainly experience did not vouch for the behavior of infinite straight lines, whereas axioms were supposed to be self-evident truths about the physical world. The parallel axiom in the form stated by Euclid(BC 330?~BC 275?) was thought to be somewhat too complicated. It lacked the simplicity of the other axioms. Apparently even Euclid did not like his version of the parallel axiom because he did not call upon it until he had proved all the theorems he could without it.

A related problem, which did not bother many people but ultimately came to the fore as a vital concern, is whether one can be sure of the existence of infinite straight lines in physical space. Euclid was careful to postulate only that one can extend a finite line segment as far as necessary, so that even the extended segment was still finite. Nevertheless Euclid did imply the existence of infinite straight lines for, were they finite, they could not be extended as far as necessary in any given context. (The Loss of Certainty P 78-79)

The historical development of non-Euclidean geometry was a result of attempts to deal with this axiom (Euclid's Fifth). (The Mathematical Experience, 218)

However, the material in Gauss's notes became available after his death in 1855 when his reputation was unexcelled and the publication in 1868 of Riemann's 1854 paper convinced many mathematicians that a non-Euclidean geometry

could be the geometry of physical space and that we could no longer be sure which geometry was true. The mere fact that there can be alternative geometries was in itself a shock. But the greater shock was that one could no longer be sure which geometry was true or whether any one of them was true. (The Loss of Certainty, 88)

The loss of certainty in geometry was philosophically intolerable, because it implied the loss of all certainty in human knowledge. Geometry had served, from the time of Plato, as the supreme exemplar of the possibility of certainty in human knowledge. (The Mathematical Experience, 331)

But by 1900 Euclidean geometry was recognized to be just a logical structure erected on a set of twenty or so man-made axioms, and it was indeed possible that contradictory theorems could turn up. (The Loss of Certainty, 198)

This confidence that truths would be discovered in all fields was shattered by the recognition that there is no truth in mathematics. The hope and perhaps even the belief that truths can be obtained in politics, ethics, religion, economics, and many other fields may still persist in human minds, but the best support for the hope has been lost. Mathematics offered to the world proof that man can acquire truths and then destroyed the proof. It was non-Euclidean geometry and quaternions, both triumphs of reason, that proved the way for this intellectual disaster. With the loss of truth, man lost his intellectual center, his frame of reference, the established authority for all thought. The "pride of human reason" suffered a fall which brought down with it the house of truth. (The Loss of Certainty, 99)

At first Gauss(1777~1855) who has discovered non-Euclid geometry seems to have concluded that there is no truth in all of mathematics. In a letter to Bassel of November 21, 1811, he said,

"One should never forget that the functions [of a complex variable], like all mathematical constructions, are only our own creations, and that when the definition with which one begins ceases to make sense, one should not ask, What is, but what is it convenient to assume in order that it remain significant."

"According to my most sincere conviction the theory of space has an entirely different place in knowledge from that occupied by pure mathematics [the mathematics built on number]. There is lacking throughout our knowledge of it the complete persuasion of necessity(also of absolute truth) which is common to the latter; we must add in humility, that if number is exclusively the product of our mind, space has a reality outside our mind and we cannot completely prescribe its laws." (The Loss of Certainty, 87)

Gauss' thoughts about the number and space become a decisive motive to give a birth of non-Euclid geometry and Georg Friedrich Bernhard Riemann(1826-1866), who are very familiar with his study, gives birth to Riemann geometry. One of Riemann's objectives was to show that Euclid's axioms were indeed empirical rather than self-evident truths. (The Loss of Certainty, 86)

Albert Einstein(1879~1955) adopted Riemann's mathematical discoveries by giving them a precise physical interpretation. (The Elegant Universe, 233)

It is not obvious whether an infinite straight line, which exists in the human imagination, is applicable to the real physical world. Einstein rather adopts Riemannian geometry in his General Theory of Relativity and, on this basis, he successfully explained the relationship between light and gravity. However, there is no heuristic evidence that reality in the physical world agrees with reality in the mathematical world.

(c) Withering of Mathematical Truth

Due to the loss of certainty in geometry, mathematicians tend to discover the truth from the arithmetic.

The immediate forerunner of modern intuitionism is Leopold Kronecker(1823~1891). His epigram (delivered in an after-dinner speech), "God made the integers; all the rest is the work of man," is well known. The complicated logical derivation of the ordinary whole numbers such as Cantor and Dedekind presented through a general theory of sets seemed less reliable than direct acceptance of the integers. (The Loss of Certainty, 232)

As for the consistency of arithmetic, no one doubted it. (The Loss of Certainty, 196)

David Hilbert(1862~1943)showed through the medium of analytic geometry that Euclidean geometry is consistent if the science of arithmetic is consistent. Hence, in his second problem he asked for a proof that the science of arithmetic is consistent. (The Loss of Certainty, 196)

However, Kurt Gödel(1906-1978) tells that it is impossible to prove the non-contradiction of arithmetic in his first incompleteness theorem (Any effectively generated theory capable of expressing elementary arithmetic cannot be both consistent and complete. In particular, for any consistent, effectively generated formal theory that proves certain basic arithmetic truths, there is an arithmetical statement that is true, but no provable in the theory (Kleene 1967, p.250)) and second incompleteness theorem (For any formal effectively generated theory T including basic arithmetical truth and also certain truths about formal provability, T includes a statement of its own consistency if and only if T is inconsistent.) Both of Gödel's results were shattering. The inability to prove consistency dealt

a death blow most directly to Hilbert's formalist philosophy because he had planned such a proof in his meta-mathematics and was confident it would succeed. Hence mathematicians were working under a threat of doom. (The Loss of Certainty, 263)

There are mathematicians who are more seriously skeptical about the self-evident truth.

Arend Heyting, leading intuitions, affirmed that no one today can speak of the true mathematics, that is, true in the sense of a correct, unique body of knowledge. Hermann Hankel(1839~1873), Richard Dedekind(1831~1916), and Karl Weierstrass(1815~1897) all believed that mathematics is a human creation. And Ludwig Wittgenstein (1889-1951), a student of Russell and an authority in his own right, believed that the mathematician is an inventor not a discoverer. Hermann Weyl(1885~1955), too, was rather ironic about eternal truths. The Nobel prize-winning physicist Percy W. Bridgman(1882~1961), in *The Logic of Modern Physics* (1946), rejected flatly any objective world of mathematics. "It is the merest truism, evident at once to unsophisticated observation, that mathematics is a human invention." Theoretical science is a game of mathematical make-believe. All these men contend that mathematics is not only man-made but very much influenced by the cultures in which it was developed. (The Loss of Certainty, 324-325)

Plato did believe that mathematics exists in some ideal world independent of human beings, his doctrines included much that does not apply to the current views, and the use of the appellation Platonist is more unsuitable than helpful. These assertions about the existence of an objective, unique body of mathematics do not explain where mathematics resides. They say merely that mathematics exists in some extra-human world, a castle in the air, and is merely detected by man. (The Loss of Certainty, 323)

The typical mathematician is both a Platonist and a formalist—a secret Platonist with a formalist mask that he puts on when the occasion calls for it. (The Mathematical Experience, 322)

Today many, perhaps most, mathematicians have no such conviction of the objective existence of the objects they study. (The Mathematical Experience, 252)

<Appendix 2> Discovery of Number

Aside from philosophers', physicists', and mathematicians' efforts to investigate truth, human beings have made mathematical meanings and used them as means to distinguish and conceive objects and all the academic systems nowadays are being helped from its departmentalized and instrumental properties. Rapid scientific achievements further diminished scientists' motives to search for the truth. Seeing the nature as an object to take advantage of, humans have created mathematics as necessary, altered, and applied. Despite of brilliant achievements, they have lost the spirits to correctly understand the nature. (The Loss of Certainty, 279~354)

We have seen that in number theory, there may be heuristic evidence so strong that it carries conviction even without rigorous proof. (The Mathematical Experience, 369)

(a) Natural Numbers

The idea that the whole numbers derive from the intuition of time had been maintained by Immanuel Kant(1724~1804), William R. Hamilton(1805~1865) in his article "Algebra as a Science of Time," and the philosopher Arthur

Schopenhauer(1788~1860)."

(The Loss of Certainty, 234 Morris Kline)

From the concept of time, Hamilton derived properties of the positive whole numbers and then extended this development to rational numbers (positive and negative whole numbers and fractions) and irrational numbers. (The Loss of Certainty, 178 Morris Kline)

However, there are opinions that oppose the statement.

The Platonist does not attempt to describe it, let alone analyze its nature. How does one acquire mathematical intuition? Evidently it varies from one person to another, even from one mathematical genius to another; and it has to be developed mathematical genius to another; and it has to be developed and refined, since it seems to be inadequate at present. But then by whom, according to what criteria, does one train or develop it? (The Mathematical Experience, 394)

The natural number system seems an innate intuition only to mathematicians so sophisticated they cannot remember or conceive of the tie before they acquired it; and so isolated that they never have to communicate seriously with people (still no doubt the majority of the human race) who have not internalized this set of ideas and made it intuitive.

(The Mathematical Experience, 395)

The concept of natural numbers which we can naturally derive from intuitions about time immediately leads us to intuitively accept that natural numbers exist sequentially on a straight line. However, this problem leads us to Euclid's Axiom 5 of the parallel postulate and we have gained only certainty without real evidence that natural numbers exist on an infinite straight line.

(b) Prime Numbers

The ancient Greeks also liked to attribute sexual qualities to numbers, but it was they who first discovered, in the 4th century BC, the primes' true potency as the building blocks for all numbers.

They saw that every number could be constructed by multiplying prime numbers together.

(The Music of the Primes, 26)

In mathematics, a prime number (or a prime) is a natural number which has exactly two distinct natural number divisors: 1 and itself. The first twenty-five prime numbers are:

2, 3, 5, 7, 11, 13, 17, 19, 23, 29, 31, 37, 41, 43, 47, 53, 59, 61, 67, 71, 73, 79, 83, 89, 97.

The property of being prime is called primality. Verifying the primality of a given number n can be done by trial divisions, that is to say dividing n by all smaller numbers m , thereby checking whether n is a multiple of m , and therefore not prime, or composite. For big primes, increasingly sophisticated algorithms which are faster than that technique have been devised.

There is no known formula yielding all primes and no composites. However, the distribution of primes, that is to say, the statistical behavior of primes in the large can be modeled. The first result in that direction is the prime number theorem which says that the probability that a given, randomly chosen number N is prime is inversely proportional to its number of digits, or the logarithm of N . This statement has been proved at the end of the 19th century. The unproven Riemann hypothesis dating from 1859 implies a refined statement concerning the distribution of primes.

Despite being intensely studied, many fundamental questions around prime numbers remain open. For example, Goldbach's conjecture which asserts that any even natural number bigger than two is the sum of two primes, or the twin prime conjecture which says that there are infinitely many twin primes (pairs of primes whose difference is two), have been unresolved for more than a century, notwithstanding the simplicity of their statements. Prime numbers give rise to various generalizations in other mathematical domains, mainly algebra, notably the notion of prime ideals.

[http://en.wikipedia.org/wiki/Prime_number#cite_note-1]

The logical argument (actually, the dilemma, which forces one to the same conclusion whichever path one is compelled to take) tells us that the list of primes never ends. The second feature of the list of primes that strikes one is the absence of any noticeable pattern or regularity. Of course all the prime numbers except 2 are odd, so the gap between any two successive primes has to be an even number. (The Mathematical Experience, 212)

Yet despite their apparent simplicity and fundamental character, prime numbers remain the most mysterious objects studied by mathematicians. Look through a list of prime numbers and you'll find that it's impossible to predict when the next prime will appear. The list seems chaotic, random, and offers no clues as to how determine the next number. It is hard to guess at a formula that could generate this kind of pattern. In fact, this procession of primes resembles a random succession of numbers much more than it does a nice orderly pattern. (The Music of The Primes, 5-6)

Like the value of π (The Mathematical Experience, 369), the properties of prime numbers are already determined regardless of human will, knowledge, reason, experience and, even though they follow no pattern and seem to be random,

their properties do not change or perish.

The following are reasons why we conceive prime numbers as uncertain:

- It is not possible to know if a number is a prime number without calculation.
- Ex) It is hard to tell which of the numbers 7866041, 7866047, and 7866051 is a prime number.
- Once we find a prime number, we are not able to predict the values (cycle, clock) of the prime number which comes after.
- Ex) It is hard to guess what the next prime number is after 19,999,909.
- Since we are not able to find the factor which determines the value of a prime number, We can't find a rule that applies to all prime numbers.

The study of prime numbers goes back to the ancient Greeks but recent discoveries have been very limited. There has been no clear significant progress on the most famous unsolved problems in mathematics such as Goldbach's conjecture, the Riemann hypothesis, twin prime conjectures, etc. Problems related to prime numbers remain a great challenge for the human spirit to conquer. The great physicist and mathematician, Johann Carl Friedrich Gauss (1777-1855), recognized the value of this problem. This is why he turned the focus of his research from light and space to prime numbers, strongly confident that mathematical objects and physical objects coincide.

<Appendix 3> Duality(Prime Number Theorem)

The German mathematician Gauss speculated that $\pi(N)$, which represents a smaller number of prime numbers than natural number N , gradually approaches $N/\log_e N$ as the natural number N becomes bigger. This was termed the Prime Number Theorem. (The Music of Primes P19~58)(Prime

Obsession, 32-47)

N	$\pi(N)$	$\frac{N}{\log N} - \pi(N)$
10^8	5,761,455	-332,774
10^9	50,847,534	-2,592,592
10^{10}	455,052,511	-20,758,030
10^{11}	4,118,054,813	-169,923,160
10^{12}	37,607,912,018	-1,416,706,193
10^{13}	346,065,536,839	-11,992,858,452
10^{14}	3,204,941,750,802	-102,838,308,636

Table – 3) Prime Number Theorem

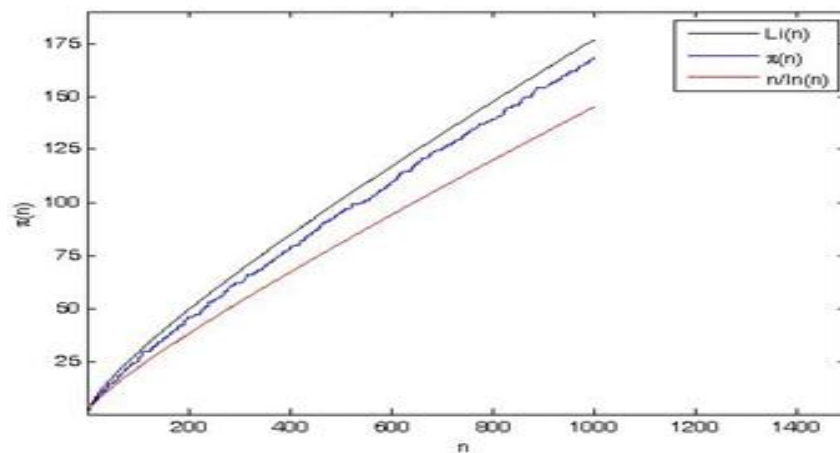

Figure – 6) The PNT(Improved Version)

Table–3) shows that $Li(x)$ is central to our whole inquiry. In fact, the PNT is most often stated as $\pi(N) \sim Li(N)$, rather than as $\pi(N) \sim N / \log N$. Because the

twiddle sign is transitive, the two things are equivalent, as can be seen in [Figure-6](#). Out of Riemann's 1859 paper came a precise, though unproven, expression for $\pi(N)$, and $Li(x)$ leads off that expression. Note just one more thing about [Table-3](#). For all the values N shown in the table, $N/\log N$ gives a low estimate for $\pi(N)$, while $Li(N)$ gives a high one. I am just going to leave that lying there as a comment, for future reference. This is merely true; it is, in a manner of speaking, truer, I mean, $Li(N)$ is actually a better estimate of $\pi(N)$ than $N/\log N$ is. A much better estimate. (Prime Obsession, 116-117)

[Figure-6](#) shows that $\pi(N)$ is smaller than $Li(N)$ and greater than $N/\log_e N$. However, similar to [Figure-6](#), mathematicians have only been able to speculate regarding $\pi(N)$'s transitional path and have not been able to define its meaning or significance.

This thesis considers that N and $\pi(N)$ of the prime number theorem are already determined regardless of human's reason, knowledge, experience and apperception. Even if we cannot reveal the factor which determines the relationship between $\pi(N)$ and N , we should pay attention to the fact that the base of the log function, $\pi(N) \sim N/\log N$, changes dynamically with N . [Table-4](#)) shows the dynamic value of $\nabla\pi$.

$$(1) \pi(N) = N / \log_{\nabla \pi} N$$

$$(2) \log_{\nabla \pi} N = N / \pi(N)$$

$$(3) \nabla \pi^{N/\pi(N)} = N$$

$$(4) \nabla \pi = N^{\pi(N)/N}$$

N	$\pi(N)$	$\pi(N) / N$	$\nabla \pi$
10	5 (1)	0.5	3.16227766
10^2	26(1)	0.26	3.31131121
10^3	169(1)	0.169	3.21366053
10^4	1,229	0.1229	3.10170149
10^5	9,592	0.09592	3.01717152
10^6	78,498	0.078498	2.95793073
10^7	664,579	0.066458	2.91880646
10^8	5,761,455	0.057615	2.89012349
10^9	50,847,534	0.050848	2.86832135
10^{10}	455,052,511	0.045505	2.85136300
10^{11}	4,118,054,813	0.041181	2.83782773
10^{12}	37,607,912,018	0.037608	2.82679909
10^{13}	346,065,536,839	0.034607	2.81763801
10^{14}	3,204,941,750,802	0.032049	2.80990634
10^{15}	29,844,570,422,669	0.029845	2.80329341

10^{16}	279,238,341,033,925	0.027924	2.79757247
10^{17}	2,623,557,157,654,233	0.026236	2.79257417
10^{18}	24,739,954,287,740,860	0.02474	2.78816953
10^{19}	234,057,667,276,344,607	0.023406	2.78425858
10^{20}	2,220,819,602,560,918,840	0.022208	2.78076264
10^{21}	21,127,269,486,018,731,928	0.021127	2.77761890
10^{22}	201,467,286,689,315,906,290	0.020147	2.77477664
10^{23}	1,925,320,391,606,803,968,923	0.019253	2.77219445

Table – 4) $\pi(N)$ and $\nabla\pi$ Distribution(Prime Number Theorem, wikipedia)

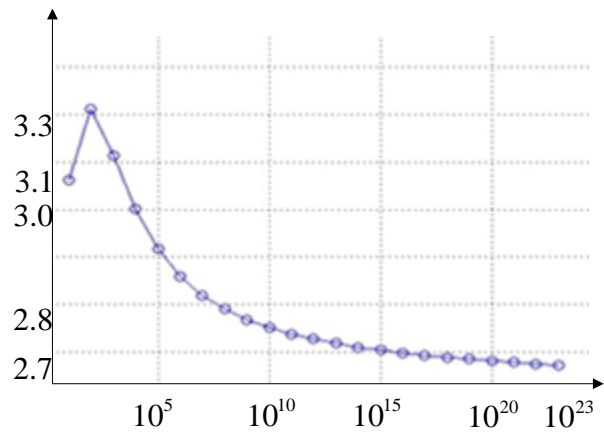
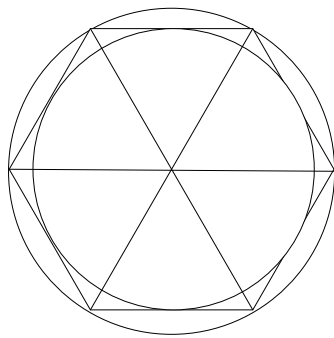

Figure – 8) Dynamic curve of prime number

Figure – 7) Dynamic model distribution of prime number distribution

From the data shown in [Table-4](#) , we have discovered that the overall prime number distribution is surprisingly very similar to the spectrum curve of light as shown in [Figure-8](#) . What does this curve mean? Based on the curve in [Figure-8](#) , I have applied a model of radius 1 and found, in spite of small differences, that it approaches the model of the contraction of the space after an expansion.

$$(1)\pi(N) = N / \log_{\nabla\pi} N ,$$

$$(2) \nabla\pi = N^{\pi(N)/N} ,$$

$$(3) \lim_{N \rightarrow \infty} \nabla\pi = \sqrt{3}\pi/2 .$$

	$\pi(N)$	$\pi(N) - N / \log_e N$	$\pi(N) - N / \log_{\sqrt{3}\pi/2} N$
10	5(1)	0.657	0.653
10^2	25	3.285	3.2659
10^3	168	23.235	23.106
10^4	1,229	143	142
10^5	9,592	906	898
10^6	78,498	6,115	6,051
10^7	664,579	44,158	43,606
10^8	5,761,455	332,773	327,948
10^9	50,847,534	2,592,592	2,549,701
10^{10}	455,052,511	20,758,029	20,372,006
10^{11}	4,118,054,813	169,923,159	166,413,864
10^{12}	37,607,912,018	1,416,705,192	1,384,536,652
10^{13}	346,065,536,839	11,992,858,451	11,695,918,077

10^{14}	3,204,941,750,802	102,838,308,635	100,081,005,159
10^{15}	29,844,570,422,669	891,604,962,453	865,870,130,004
10^{16}	279,238,341,033,925	7,804,289,844,393	7,563,025,790,186
10^{17}	2,623,557,157,654,233	68,883,734,693,929	66,613,014,183,740
10^{18}	24,739,954,287,740,860	612,483,070,893,537	591,037,377,186,201
10^{19}	234,057,667,276,344,607	5,481,624,169,369,961	5,278,454,439,510,988
10^{20}	2,220,819,602,560,918,840	49,347,193,044,659,702	47,417,080,610,999,452
10^{21}	21,127,269,486,018,731,928	446,579,871,578,168,707	428,197,848,400,452,034
10^{22}	201,467,286,689,315,906,290	4,060,704,006,019,620,995	3,885,239,239,323,234,570
10^{23}	1,925,320,391,606,803,968,923	37,083,513,766,578,631,310	35,405,155,128,613,195,945

Table – 5) The limiting value of $\nabla\pi$

Table – 5) shows that the limit of $\nabla\pi$ is not the value e (2.71828) defined in the Prime Number Theorem but it approaches $\sqrt{3\pi/2}$ (2.720699). Based on this fact, the limiting value of the expansion and contraction of $\nabla\pi$ is determined with certainty.

How certain on the limiting value? We have no alternative but to confirm.

But for conjectures such as those about the distribution of primes, no one believes that the behavior we observe in our sample will suddenly change to something radically different in another sample, taken farther out toward infinity. (The Mathematical Experience, 367)

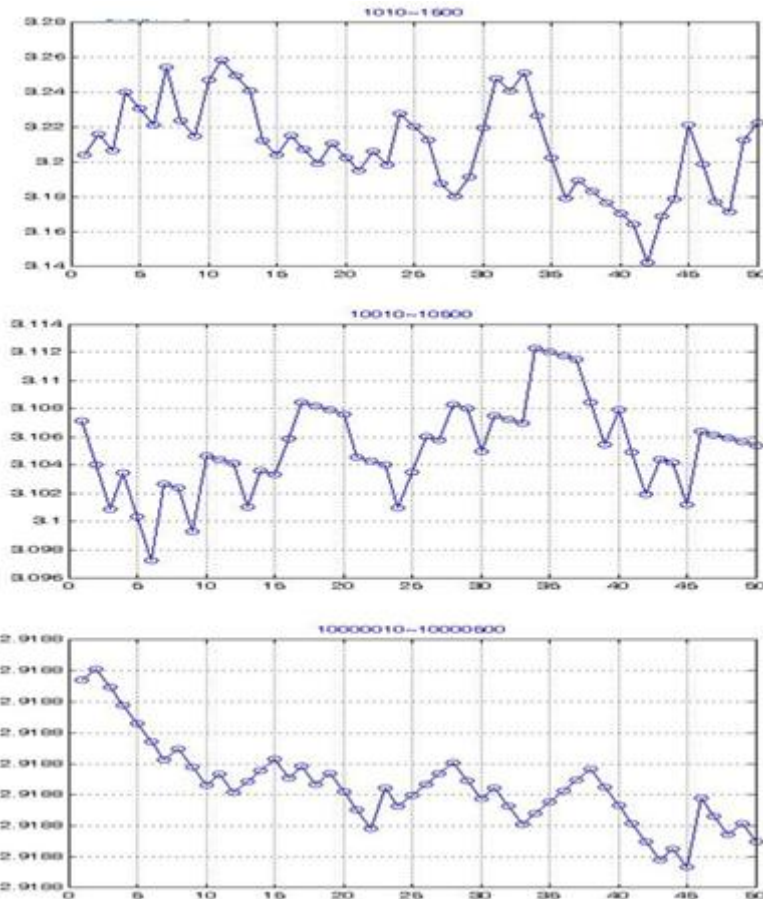

Figure-9) Local (Partial) Properties of Prime Number Distribution

In Figure-8), the distribution of prime numbers appears to take the shape of a smooth curve, but Figure-9) shows that they fluctuate with their distribution being locally unpredictable.

In Figure-9), the spacing between natural numbers is set to 10. By measuring the number of prime numbers in intervals of 10, we find the value of $\nabla\pi$.

In 1010 ~ 1500, 10010 ~ 10500, 10000010 ~ 10000500, we applied 3 different numerical models as a sample.

In this thesis, I have found the dual properties that the distribution of prime numbers is locally fluctuating but wholly approaches a single point asymptotically in a smooth curve. This duality exists because a prime number is determined uncertainly by the properties of the matrix.

<Appendix 4> Addition of Primes(Goldbach's conjecture)

The problem of prime number addition has a deep relationship with Goldbach's famous conjecture.

“Every even integer greater than 2 can be written as the sum of two primes”

In this section, we will examine how even numbers are combined using the addition of odd numbers, the addition of the $12n+1,5,7,11$ sequence, and the addition of prime numbers.

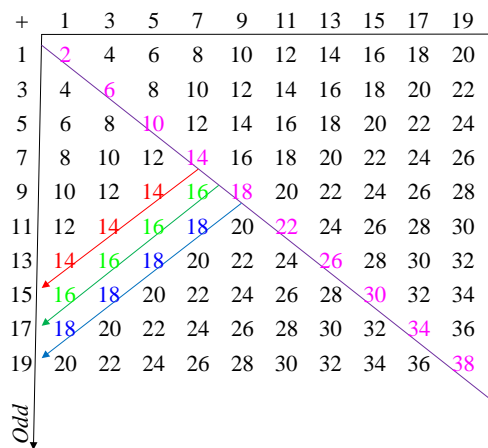

Figure -10) Addition of odd numbers

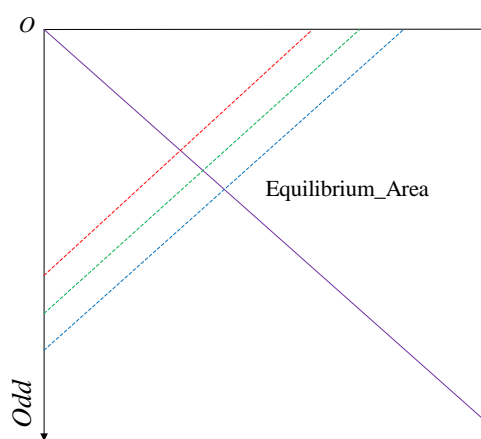

Figure -11) Model of odd numbers

In Figure-10) and Figure-11) , the additions of odd numbers from the sequence yield a non-changing pattern in the equilibrium area independent of the magnitude of the vector in the multiplication table.

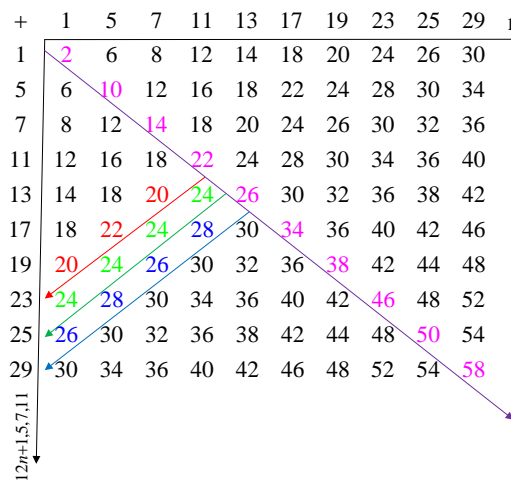

Figure –12) Addition of $12n+1,5,7,11$ Sequences

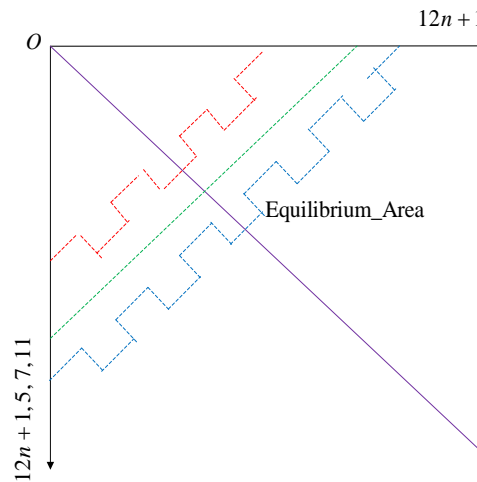

Figure –13) Model of $12n+1,5,7,11$ sequence

In Figure–12) and Figure–13), the additions of the $12n+1,5,7,11$ sequence yield a repetition with an oscillating pattern in the equilibrium area independent of the magnitude of the vector in the multiplication table.

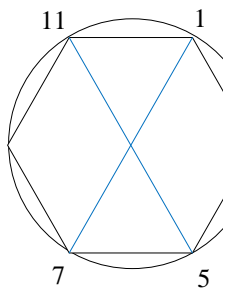

Figure –14)

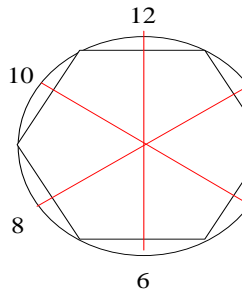

Figure –15)

+	A_1	A_5	A_7	
A_1	$A_1 + A_1$	$A_1 + A_5$	$A_1 + A_7$	A_1
A_5	$A_5 + A_1$	$A_5 + A_5$	$A_5 + A_7$	A_5
A_7	$A_7 + A_1$	$A_7 + A_5$	$A_7 + A_7$	A_7
A_{11}	$A_{11} + A_1$	$A_{11} + A_5$	$A_{11} + A_7$	A_{11}

Figure –16)

In Figure–14), we have modeled 4 groups of the $12n+1,5,7,11$ sequence. Based on Figure–14), we have added the tables in Figure–16). Figure–15) is a modeling of the

results from

Figure –16).

2	4	6	8	10	12
$A_1 + A_1$ $A_7 + A_7$	$A_5 + A_{11}$	$A_1 + A_5$ $A_7 + A_{11}$	$A_1 + A_7$	$A_5 + A_5$ $A_{11} + A_{11}$	$A_1 + A_{11}$ $A_5 + A_7$
$(12x+1)+(12y+1)$ $(12x+7)+(12y+7)$	$(12x+5)+(12y+11)$	$(12x+1)+(12y+5)$ $(12x+7)+(12y+11)$	$(12x+1)+(12y+7)$	$(12x+5)+(12y+5)$ $(12x+11)+(12y+11)$	$(12x+1)+(12y+11)$ $(12x+5)+(12y+7)$
$12x + 12y + 2$ $12x + 12y + 14$	$12xy + 12y + 16$	$12x + 12y + 6$ $12x + 12y + 18$	$12x + 12y + 8$	$12x + 12y + 10$ $12x + 12y + 22$	$12x + 12y + 12$ $12x + 12y + 12$
2	1	2	1	2	2

Table – 6) $12n+1,5,7,11$ Addition of Prime Numbers in the Table

Addition of the $12n+1,5,7,11$ sequence has the property that when it is combined into any of the even numbers, the ratios of the combined even numbers are uniform.

$$2(\text{clock}) : 4(\text{clock}) : 6(\text{clock}) : 8(\text{clock}) : 10(\text{clock}) : 12(\text{clock}) = 2:1:2:1:2:2.$$

Since the distribution of the $12n+1,5,7,11$ sequence in Table –6) is uniform, the ratios of the combined even numbers are also uniform.

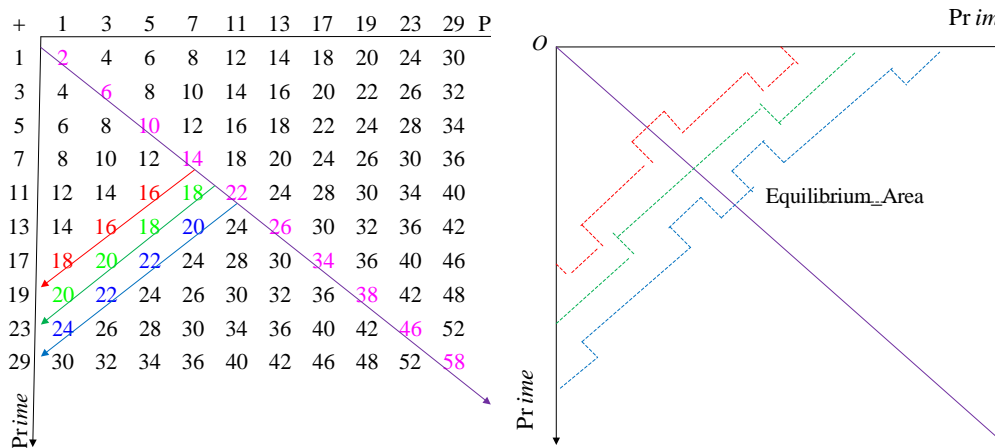

Figure –17) Addition of Prime Numbers *Figure –18) Model of Prime number*

Figure –17) and Figure –18) ; With the additions of prime numbers, as the magnitude of vectors in the multiplication table increases, the intertwined phenomena become more complicated in the equilibrium area. In recent times, Goldbach's conjecture has been proven to be true up to 12×10^{17} using computer calculations. In *Figure –17)*, as the vector in the multiplication table increases, the number of even numbers is increasing. This finding agrees with existing statistical data. Oliveira e Silva (Jul. 14, 2008).

In 3(c), due to the uncertainty of the prime number distribution, it is impossible to express a generalized equation regarding the addition of prime numbers. However, we can apply it infinitely if we are certain of the heuristic evidence that ① the prime numbers can be sorted into 4 groups in 3(a); ② there is a factor which determines even numbers in 3(e); ③ the prime numbers follow the rules of the multiplication table; and ④ the distribution of prime numbers approaches a certain point.

<Appendix 5> Seeking Truth

The concept of symmetry is exciting and mysterious in many ways, and it is a very natural phenomenon for us to understand. It has become an object of physics and sometimes of mathematics but the concept itself is not easy to understand. The reason it is both easy and difficult is that it is metaphysically and physically too broad and that each person has a different conception of what it means. There is also a big reason why today's physicists have a deep interest in symmetry. This concept is being applied to many natural phenomena examined today. But the most important point is that it is recognized deeply by physicists as a physical law which never varies.

(a) Meaning of Symmetry

Professor Hermann Weyl has given this definition of symmetry: a thing is symmetrical if one can subject it to a certain operation and it appears exactly the same after the operation. For instance, if we look at a vase that is left-and-right symmetrical, then turn it 180° around the vertical axis, it looks the same. We shall adopt the definition of symmetry in Weyl's more general form, and in that form we shall discuss symmetry of physical laws. (Six Not So Easy Pieces , 1)

In fact, we will see that the history of the universe is, to a large extent, the history of symmetry.

This symmetry is known as translational symmetry or translational invariance. It applies not only to Newton's laws but also to Maxwell's laws of electromagnetism, to Einstein's special and general relativities, to quantum mechanics, and to just about any proposal in modern physics that anyone has taken seriously. Considerations of symmetry have clearly been indispensable in the development of modern cosmological theory. (THE FABRIC OF THE COSMOS, 219~250)

A fact that most physicists still find somewhat staggering, a most profound and beautiful thing, is that, in quantum mechanics, for each of the rules of symmetry there is a corresponding conservation law; there is a definite connection between the laws of conservation and the symmetries of physical laws. (Six Not So Easy Pieces, 29)

The marvelous thing about it all is that for such a wide range of important, strong phenomena-nuclear forces, electrical phenomena, and even weak ones like gravitation-over a tremendous range of physics, all the laws for these seem to be symmetrical. (Six Not So Easy Pieces, 46)

Now our problem is to explain why they are nearly symmetrical by looking at tidal forces and so

on. Richard Phillips Feynman(1918~1988) (Six Not So Easy Pieces, 47)

Heigenberg(1971) states in his book, 'Physics And Beyond', that it is natural to say that the symmetry is the fundamental element which the nature have plan to create. 'In the beginning was symmetry' is certainly a better expression than Democritus 'In the beginning was the particle.'

Elementary particles embody symmetries; they are their simplest representations, and yet they are merely their consequence. (Physics And Beyond, 240)

What are the differences between mathematical symmetry and physical symmetry? What are the differences between reality in mathematics and that in physics? What are the differences between the determined properties of π (The Mathematical Experience, 369-374), those of prime number distribution, and those of spaces? What we are certain of is that reality in both mathematics and physics are already determined and invariant regardless of human experience and reason.

(b) Search for the Truth

Today mathematical description and not physical explanation is the goal in science.

At best mathematics describes some processes of nature, but its symbols do not contain all of it. Even in the physical realm, mathematics deals with simplifications which merely touch reality as a tangent touches a curve at one point. (The Loss of Certainty, 25)

In his Philosophy of Mathematics and Natural Science(1949), Weyl conceded:

How much more convincing and closer to facts are the heuristic arguments and the subsequent systematic constructions in Einstein's general relativity theory, or the Heisenberg-Schrödinger quantum mechanics. A truly realistic mathematics should be conceived, in line with physics, as a branch of the theoretical construction of the one real world, and should adopt the same sober and cautious attitude toward hypothetic extensions of its foundation as is exhibited by physics. (The Loss of Certainty, 330)

Godfrey H. Hardy(1877~1947) expressed the same view in his book A Mathematician's Apology:

I believe that mathematical reality lies outside us, that our function is to discover or observe it , and that the theorems which we prove, and which we describe grandiloquently as our "creations." are simply our notes of our observations. (The Loss of Certainty, 322)

Hermite offered this explanation of the accord between mathematics and science: There exists, if I am not deceived, a world which is the collection of mathematical truths, to which we have access only through our intellects, just as there is the world of physical reality; the one and the other independent of us, both of divine creation, which appear distinct because of the weakness of our minds, but for a more powerful mode of thinking are one and the same thing. The synthesis of the two is revealed partially in the marvelous correspondence between abstract mathematics on the one hand and all the branches of physics on the other. (The Loss of Certainty, 345)

Later in life Eddington(1882~1944) too became convinced that nature is mathematically designed and he affirmed categorically in Fundamental Theory(1946) that our minds can build up a pure science of nature from a priori knowledge. This science is the only one possible; any other one would contain logical inconsistencies. (The Loss of Certainty, 346)

In another passage Einstein reaffirmed his belief through the now famous phrase about God: "I, at any rate, am convinced that He does not throw dice." And if He does, then, as Ralph Waldo Emerson once suggested, "The dice of God are always loaded." Einstein is not affirming here that the mathematical laws we now have are the correct ones but that there are such, and we can hope to come closer and closer to them. As he put it, "God is subtle; He is not malicious."

(The Loss of Certainty, 347)

More recently (1945) Erwin Schrödinger(1887~1961) in *What Is Life* said that the miracle of man's discovering laws of nature may well be beyond human understanding. Another physicist, the highly distinguished Freeman Dyson agrees: "We are probably not close yet to understanding the relation between the physical and the mathematical worlds." (The Loss of Certainty, 349)

What is surprising is that even some of the leaders in the work on foundations-Hilbert, Alonzo Church, and the members of the Bourbaki school-affirm that the mathematical concepts and properties exist in some objective sense and that they can be apprehended by human minds. Thus mathematical truth is discovered not invented. What evolves is not mathematics but man's knowledge of mathematics. (The Loss of Certainty, 323)

As Erwin Schrödinger has pointed out, it may be beyond the scope of the human understanding to discover the laws of nature. But, we need to remind of what Rene Descartes(1596~1650) says on the other hand. "I shall preserve until I find something that is certain or, at least, until I find for certain that nothing is certain". (The Loss of Certainty, 327)

If we accept the indications of leading scholars, our objective becomes obvious.

Self-evident truth is not an invention but a discovery. This thesis has found that symmetry, a physical attribute, and prime numbers, a mathematical object, coexist. Also, from the fact that the distribution of prime numbers exists in spatial, symmetric, and periodic dimensions, we have found that the set of all natural numbers, which also includes the set of all prime numbers, is not separated from space and in fact coexists with space, as opposed to the claims of Immanuel Kant and Hamilton that we accept the concept of natural numbers from intuitions about time. It is hard to say here how to interpret this finding and what implications it has. However, as a result of this discovery, there absolutely exists an object of self-evident truth and it is very different from the mathematical and physical conception of it we have known until now. Human beings are incomplete existences who can easily believe in the existence of a thing which does not exist. It is impossible to know which objects are out there and which objects are not, and which is possible and which is impossible. Perhaps here we should recall the words of Francis Bacon (1561~1626), who said that our conception receives information with endless distortion and that as a result we lose certainty. The reason human beings search for truth is closer to instinct than any other and the goal is to obtain a higher dimensional certainty through discoveries of truth.

<Appendix 6> Attached document

5	7	11	13	17	19	23	25	29	31	35	37	41	43	47	49	53	55	59	
							25 _(Gb₁)			35 _(Go₁Gp₁)					49 _(G₁)		55 _(Gk₁G_l₁)		
5	7	11	13	17	19	23		29	31			37	41	43	47		53	59	
61	65	67	71	73	77	79	83	85	89	91	95	97	101	103	107	109	113	115	119
	65 _(Ge₁G_f₁)				77 _(Gg₁G_h₁)			85 _(Gb₁)		91 _(Gi₁G_j₁)	95 _(Go₁)						115 _(Gk₁)	119 _(Gp₁)	
61		67	71	73			79	83	89				97	101	103	107	109	113	

121	125	127	131	133	137	139	143	145	149	151	155	157	161	163	167	169	173	175	179
121 _(Gd₁)	125 _(Gf₁)			133 _(Gc₁)			143 _(Gm₁Gn₁)	145 _(Gb₁)			155 _(Go₁)		161 _(Ge₁)			169 _(Ga₁)		175 _(Gj₁Gk₁)	
		127	131		137	139			149	151		157		163	167		173		179
181	185	187	191	193	197	199	203	205	209	211	215	217	221	223	227	229	233	235	239
	185 _(Gf₁)	187 _(Gi₁)					203 _(Gp₁)	205 _(Gb₁)	209 _(Gh₁)		215 _(Go₁)	217 _(Gc₁)	221 _(Ge₁)					235 _(Gk₁)	
181			191	193	197	199				211				223	227	229	233		239
241	245	247	251	253	257	259	263	265	269	271	275	277	281	283	287	289	293	295	299
	245 _(Gf₁Gg₁)	247 _(Gi₁)		253 _(Gd₁)	257 _(Gj₁)		263 _(Gh₁)				275 _(Gn₁Go₁)				287 _(Gp₁)	289 _(Gb₂)		295 _(Gk₁)	299 _(Gm₁)
241			251		257		263		269	271		277	281	283				293	
301	305	307	311	313	317	319	323	325	329	331	335	337	341	343	347	349	353	355	359
301 _(Gc₁)	305 _(Gf₁)					319 _(Gi₁)	323 _(Go₂Gp₂)	325 _(Gn₁Gh₁)	329 _(Gg₁)		335 _(Go₁)		341 _(Gh₁)	343 _(Gj₁)				355 _(Gk₁)	
		307	311	313	317					331		337			347	349	353		359
361	365	367	371	373	377	379	383	385	389	391	395	397	401	403	407	409	413	415	419
361 _(Gc₂)	365 _(Gf₁)		371 _(Gp₁)		377 _(Ge₁)			385 _(Gb₁Gc₁Gd₁)		391 _(Gk₂Gl₂)	395 _(Go₁)			403 _(Gi₁)	407 _(Gn₁)		413 _(Gg₁)	415 _(Gk₁)	
		367		373		379	383		389			397	401			409			419
421	425	427	431	433	437	439	443	445	449	451	455	457	461	463	467	469	473	475	479
	425 _(Gf₁Ge₂Gf₂)	427 _(Gi₁)			437 _(Gg₂Gh₂)			445 _(Gh₁)	451 _(Gi₁)	455 _(Gm₁Go₁Gp₁)					469 _(Gc₁)	473 _(Gh₁)	475 _(Gk₁Gi₂Gj₂)		
421			431	433		439	443		449				457	461	463	467			479
481	485	487	491	493	497	499	503	505	509	511	515	517	521	523	527	529	533	535	539
481 _(Ga₁)	485 _(Gf₁)			493 _(Gb₂)	497 _(Gg₁)			505 _(Gh₁)		511 _(Gj₁)	515 _(Gp₁)	517 _(Gd₁)			527 _(Go₂)	529 _(Gd₂)	533 _(Ge₁)	535 _(Gk₁)	539 _(Gn₁Gp₁)
		487	491			499	503		509				521	523					

541	545	547	551	553	557	559	563	565	569	571	575	577	581	583	587	589	593	595	599
	545 _(Gf₁)		551 _(Gp₂)	553 _(Gc₁)		559 _(Gi₁)		565 _(Gb₁)			575 _(Gm₂Gn₂Go₁)		581 _(Gg₁)	583 _(Gl₁)		589 _(Gc₂)		595 _(Gj₁Gk₁Gt₁)	
541		547			557		563		569	571		577			587		593		599
601	605	607	611	613	617	619	623	625	629	631	635	637	641	643	647	649	653	655	659
	605 _(Gf₁Gh₁)		611 _(Gm₁)				623 _(Gp₁)	625 _(Go₂Gb₁)	629 _(Gf₂)		635 _(Go₁)	637 _(Ga₁Gc₁)				649 _(Gd₁)		655 _(Gk₁)	
601		607		613	617	619				631			641	643	647		653		659
661	665	667	671	673	677	679	683	685	689	691	695	697	701	703	707	709	713	715	719
	665 _(Gf₁Gg₁Gh₂)	667 _(Gl₂)	671 _(Gn₁)			679 _(Gj₁)		685 _(Gb₁)	689 _(Ge₁)		695 _(Go₁)	697 _(Gb₂)		703 _(Gj₂)	707 _(Gp₁)		713 _(Gh₂)	715 _(Gi₁Gk₁Gl₁)	
661				673	677		683			691			701		709				719
721	725	727	731	733	737	739	743	745	749	751	755	757	761	763	767	769	773	775	779
	721 _(Gc₁)	725 _(Gf₁Ge₂)		731 _(Go₂)		737 _(Gh₁)		745 _(Gb₁)	749 _(Gg₁)		755 _(Go₁)			763 _(Gj₁)	767 _(Gm₁)			775 _(Gi₁Gk₁)	779 _(Gp₂)
			727		733		739	743		751		757	761			769	773		
781	785	787	791	793	797	799	803	805	809	811	815	817	821	823	827	829	833	835	839
	781 _(Gd₁)	785 _(Gf₁)		791 _(Gp₁)	793 _(Ga₁)		799 _(Gk₁)	803 _(Gn₁)	805 _(Gh₁Gc₁Gd₂)			815 _(Go₁)	817 _(Gc₂)				833 _(Gg₁Gf₂)	835 _(Gk₁)	
		787			797					809	811			821	823	827	829		839
841	845	847	851	853	857	859	863	865	869	871	875	877	881	883	887	889	893	895	899
	841 _(Gb₃)	845 _(Ge₁Gf₁)	847 _(Gj₁Gl₁)	851 _(Gn₂)				865 _(Gb₁)	869 _(Gh₁)	871 _(Gi₁)	875 _(Go₁Gp₁Gm₂)					889 _(Gc₁)	893 _(Ge₂)	895 _(Gk₁)	899 _(Go₃Gp₂)
				853	857	859	863					877	881	883	887				
901	905	907	911	913	917	919	923	925	929	931	935	937	941	943	947	949	953	955	959
	901 _(Gb₂)	905 _(Gf₁)		913 _(Gd₁)	917 _(Gg₁)		923 _(Gm₁)	925 _(Gb₁Ga₂)		931 _(Gj₁Gf₂)	935 _(Gn₁Go₁Go₂)			943 _(Gl₂)		949 _(Ga₁)		955 _(Gk₁)	959 _(Gp₁)
		907	911			919			929				937	941		947		953	
961	965	967	971	973	977	979	983	985	989	991	995	997							
	961 _(Gc₃)	965 _(Gf₁)			973 _(Gc₁)		979 _(Gl₁)		985 _(Gb₁)	989 _(Gh₂)		995 _(Go₁)							
		967	971			977		983			991		997						

Figure) If you knew the composite numbers less than 1000, you can filter out the prime numbers.

