

RADIATIONS

Vladislav Konovalov

Abstract

In the article the different kinds of radiations are considered

Bremsstrahlung and magnito-bremsstrahlung

Official physics considers, that the driving electric charge beams electromagnetic waves, both at positive, and at negative acceleration. The writer insists that the Bremsstrahlung is possible only, i.e. at negative acceleration of electric charge. Let's consider the elementary case, when the electric charge moved accelerated in an electrical field between points with a potential difference U . Apparently, that thus it will receive energy:

$$E = eU \quad (1).$$

The experiment confirms, that the energy of this charged particle is truly determined by the formula (11.5.1). But on presentation of official physics the considered particle at accelerated motion should beam energy as electromagnetic waves and its final energy on a considered section will be:

$$E = eU - E_{rad} \quad (2),$$

Where E_{rad} - energy lost on radiation. Thus, the notions of officious in this problem contradict experiment.

It is known, that in linacs of particles of electromagnetic radiation it is few (Physics of a microcosmos, M., 1980, page 442). The minor radiation is connected not with accelerated moving particle, and with oscillations it on motion trajectory, which it is impossible to eliminate one completely.

As any particle is gone on a screw line, a step of this screw line or circuit of cross section it will be peer to a wavelength de Broglie:

$$\lambda = \frac{h}{mV} \quad (3).$$

In (3) wavelength λ we shall express through frequency ν :

$$\nu = \frac{mV^2}{h} \quad (4),$$

but in numerator (4) there is a total energy of a particle E , presenting the sum of kinetic energy of translational and tangential motion on a screw line:

$$E = h\nu \quad (5).$$

Thus, the formula (5) is fair not only for photons, but also for any microparticles not relativistic, relativistic and ultra relativistic (if at a conclusion (5) to deal with speed of light, and mass to imply, including relativistic mass). If the charged particle with initial velocity V will receive negative acceleration, it will lose energy on a Bremsstrahlung with an ionization continuum. The maximum of this radiation is on frequency:

$$\nu_0 = \frac{mV^2}{2h} \quad (6),$$

that coincides the formula of official physics (B.M. Javorsky, A.A. Detlaf. The reference book on physics, M., 1964, page 532). The formula (6) becomes understandable of a figure 1 linear dependences of energy of a particle and frequency of the circulation on a screw line. Pursuant to an energy conservation law the maximum frequency of a Bremsstrahlung should be come on a point applicable to half of initial energy of a particle. If this value to substitute in (5) that we shall receive (6).

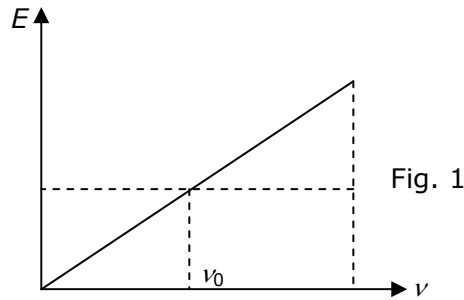

Now we shall consider explicitly mechanism of originating cyclotron (nonrelativistic particles) and synchrotron (relativistic particles) of radiation. The necessity for such consideration has two reasons. At first, these radiations are extremely relevant for a cosmology, since bear the unique information on processes happening in a far space. Secondly, the reasons of originating of these radiations not so are simple, as they are introduced to official science: the electric charge, moving on a circumference, has a centripetal acceleration, therefore beams electromagnetic waves. We just have shown, that at positive acceleration the electric charge does not beam. Probably, that a centripetal acceleration positive, therefore official explanations are not convincing.

By activity of so-called cyclic accelerators of particle them urge by that or different way to move on a circumference or on a spiral. Thus the intensive electromagnetic radiation is watched. The frequency of this radiation basically is connected to cyclical frequency of passing of accelerated particles with a charge q by the spectator being reverse value of cycle time of a particle:

$$\omega = \frac{qH}{mC} \quad (7),$$

where H - magnetic density, m - particle mass, C - electrodynamic constant, equal speed of light for a CGS system.

One reason of radiation is obvious: the particles do not move strictly on the trajectory, assigned by it, and oscillate about an equilibrium orbit and these oscillations not harmonic. They are caused by different methods of phasing and focusing of particles. Therefore we can watch a continuous spectrum of radiation, ruled spectrum and obertone, aliquot base frequency of radiation. All these kinds of radiation are connected to dipole radiation of accelerated particles by being harmonic oscillators with a considerable fraction nonharmonic component. It is connected that the cyclic accelerator represents huge model of atom of Hydrogenium. Similarly, how in atom of Hydrogenium on any orbit the electron commits not simple harmonic motions concerning a equilibrium orbit of the Bohr (see chapter 13.3), in a cyclic accelerator the accelerated particles also commit not simple harmonic motions concerning an equilibrium orbit, that is accompanied by radiation both ionization continuum and close set spectral lines.

The second reason is connected to negative acceleration in a direction opposite to motion of any charged particles, which one have component speed a perpendicular to magnetic field. It is a generalpurpose reason. It causes a Bremsstrahlung at motion of a particle in a magnetic field on any curvilinear trajectory. To understand reasons of originating of this radiation we are converted to a figure 2.

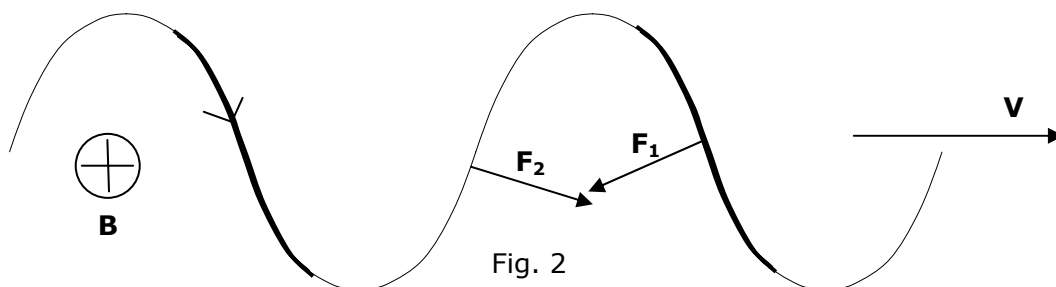

On a figure 2 induction of a magnetic field B is directed from us. The electron is gone on a screw trajectory in a direction V . In the lower half-coil of a trajectory on an electron the force of the Lorentz F_2 accelerating its motion acts, and in the upper half-coil of a trajectory the force F_1 braking an electron acts. It also causes a Bremsstrahlung. Both indicated forces have components, which one urge an electron to revert of vector V clockwise, i.e. the general trajectory of an electron in a magnetic field is curvilinear. The figure 2 demonstrates, that the space magnetic fields can not accelerate particles. Besides in space there is nobody to phase and to focalize a particles flux, as it is made in accelerators. Therefore space radiation is furnished of secondary electromagnetic radiations.

At motion of a nonrelativistic particle the radiation is directed perpendicularly orbital planes. At motion of a relativistic particle without dependence, how it is directed at not relativistic velocities, the radiation is concentrated as a ray in a current of traffic, backwards radiation misses. Besides as a result of Doppler effect the radiated frequency is considerably increased. The details of motion of beaming relativistic object are particularized in chapter 24.8 [1]. There is shown, that the formula for Doppler effect of a special relativity theory (SRT) is falsely and does not correspond to an energy conservation law. Therefore all formulas of official physics should not contain a term $\beta = V/C$. Nevertheless, they contain this term and it very conveniently for scientific gamble, since for a relativistic velocity of motion $\beta \approx 1$ and in term of $1 - \beta$ it is easy to receive any desirable value at a slightest alteration of speed, and alteration of speed on such value cannot be tested. Besides in chapter 5.2 [1] is shown, that any formula SRT similar formula (5.2.1) [1] is completely unsuitable for relativistic velocities of motion.

It is easy to show, that the negative acceleration under operating of force F_1 , operable on a charged particle of the figure 2 in accuracy is equal to a centripetal acceleration in the terms of official physics:

$$a = \frac{V^2}{r} \quad (8),$$

therefore there is no necessity for a conclusion of all available formulas depicting cyclotron and synchrotron emission. The alone remark concerns only to a term β in these formulas which have been set up above.

The electron on a trajectory of an accelerator saves screw motion, at which one the forward speed is peer to a tangential velocity, therefore speed on an orbit of a screw line makes:

$$V_0 = V\sqrt{2} \quad (9),$$

Constituent of force F_1 resulting in to braking of a particle:

$$F_0 = F_1 \cdot \frac{\sqrt{2}}{2} \quad (10).$$

On the other hand, F_1 is force of the Lorentz:

$$F_1 = \frac{V_0 q H}{C} \quad (11),$$

and the force F_0 causes pursuant to the second Newton's law negative acceleration:

$$a = \frac{F_0}{m} \quad (12).$$

By substituting in (12) expressions (9), (10) and (11), we shall discover:

$$a = \frac{VqH}{mC} \quad (13).$$

If in (8) to substitute instead of r a radius of a circumference, on which one the charged particle in a homogeneous magnetic field with tension H is gone, we shall receive (13). This example once again demonstrates, that in science frequently it is possible to receive the same outcomes, outgoing from opposite representations. Apparently, the Creator receives in such cases huge pleasure, watching, as each of the opponents with passionately proves the rightness.

In conclusion of this chapter some remarks concerning a Cherenkov radiation.

On notions of new physics the speed of light in matter with index of refraction n is determined by a polarization track, which one arises from a charged neutrino and

antineutrino of a photon. For transparent mediums this polarization is completely convertible, i.e. at deviation of electrons of matter from an equilibrium position they have time to return to a reset state, returning a photon energy which is expended on polarization. Environment having free or is loosely bound electrons strongly occludes photons because of irreversible polarization. Thus, environment itself determines a running speed in it of photons. If in environment the charged particle with speed superior speed of photons this environment will move, it guarantees, that the polarization caused by a charged particle, certainly becomes irreversible - electrons have no time to return the obtained energy and it appear in an excited state, since the particle «has escaped» from them. Alone path to be saved of this excited state independently to return to equilibrium state. This process is accompanied by radiation as cone, on top which one there is a charged particle, moving faster photons.

Electromagnetic radiation

The contents of this chapter does not correspond to its title in that sense, as it is accepted by official physics. As is spoken in Russian saying: «Fedot, yes not that».

Electrical and gravitational field have an infinite expansion, do not comprise any energy and can not therefore it transmit. Differently there is a power paradox similar to a photometric paradox for the infinite Universe. Density of a field subsides in inverse proportion to a square of spacing interval from a source of a field, and the area of a spherical layer is directly proportional to a square of spacing interval from a source of a field, i.e. total of energy in each layer permanently, and as quantity of layers is indefinite, the general energy is indefinitely great, that is apparent physical nonsense. Therefore, the field does not contain energy, therefore has not mass and is diffused in vacuum with indefinitely by a high speed. Official physics is erratic asserts, that the electrostatic field is a particular case of an electromagnetic field. This aiming to change an electrostatic field electromagnetic understandably - it is less irresolvable problems, though the mixing of heterogeneous physical objects is inadmissible. Containers for energy can serve only restricted in space of formation (for example, particles). In this sense the photons are practically clean energy, since mass them is insignificant is small, but it, nevertheless, limits speed of their motion to speed of light.

The long-wave electromagnetic radiation (radio wave) also represents a flow of photons and official physics it is forced to recognize, even if there is no such desire. As is known, the theory of the Maxwell of electromagnetic radiation ignores representation about photons. On the Maxwell the electromagnetic wave represents orthogonally related transverse vibrations electrical and magnetic field, as shown in a figure 3.

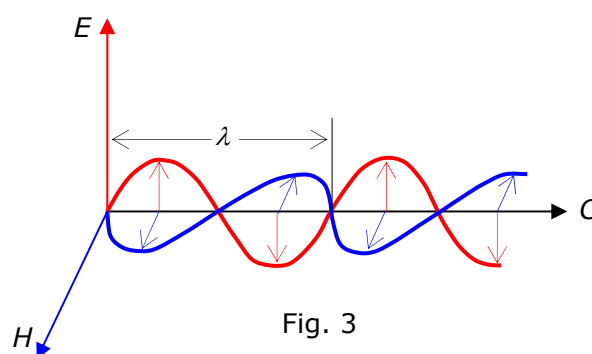

Fig. 3

At once there is such problem: how this surge to present in space? Apparently, that the electromagnetic radiation is not diffused as cords, similar figure 3. Otherwise space communication will become impossible, since spacing interval between «cords» where there is no radiation will become too large, as the wave amplitude is limited. Besides at interplay of electromagnetic radiation with matter physically approve oneself only electrical component, though under the theory of the Maxwell magnetic component not less intensive. The physical reasons making to allot radiation from the antenna by miscellaneous polarization planes which one consider conterminous with as a plane of vibration of a magnetic field are vague also. Even reasons of motion of an electromagnetic wave are not clear. Consider, that the variable electrical field causes a variable magnetic field, which one,

in turn, excites an electrical field etc. Thus remains vague, why the electromagnetic field is diffused in the given direction, instead of in what or another. From experiments it is known, that the variable electrical field excites occurrence of a variable magnetic field and on the contrary, but all similar experiments were conducted with indispensable by participation of the intermediators as charged particles. In a blank space «clean» electrical or the magnetic field is not capable to create the opponent, that demonstrates absence of electromagnetic waves which are radiated rectilinearly driving electric charge, though in each point of space electrical and the magnetic field of this charge continuously varies. Let, despite of the pronounced oppositions, the electromagnetic wave by any wonderful image all the same is moves in space. The leading crest of a wave on the logic of the theory of the Maxwell should generate two crest till both parties of two nodes of wave with an opposite direction of vectors electrical and magnetic field. Apparently, that thus the energy of the leader should decrease twice. The new leader having twice smaller energy prolongs forward motion, and the outsider is gone in the opposite direction and already never will catch up the leader. Prolonging these reasoning, we come to a conclusion, that the energy of an electromagnetic wave should fast decrease in geometrical progression, therefore propagation of electromagnetic oscillation in space is impossible.

The wave of the Maxwell is a running transverse wave. From a figure 3 it is visible, that in some points of space tension electrical and the magnetic fields become simultaneously zero. It is possible only in the event that space, in which one are diffused with speed of light of lateral vibrations, has large electrical and magnetic «resiliency» i.e. it not a blank space, and electromagnetic ather. Otherwise periodic disappearance electrical and magnetic field and again their birth from nothing contradicts an energy conservation law. To criticize the theory of ather it is senseless, since how many supporters of existence of an ather, are so much also miscellaneous athers.

Notions of new physics concerning «electromagnetic waves» length exceeds which one 0.1 mms are reduced to following. At braking electric charges in the antenna the stored energy as an antineutrino is beamed at positive halfcycle and neutrino at negative halfcycle, which one have some impulse. As a whole, for one oscillation period in the antenna in space the pair is beamed: the neutrino - antineutrino for which one a direction of an electrical field is opposite. In diagram form it is shown for the vertical antenna with length to an equal half to length of a radiated wave on a figure 4a side-view and figure 4b a plan view.

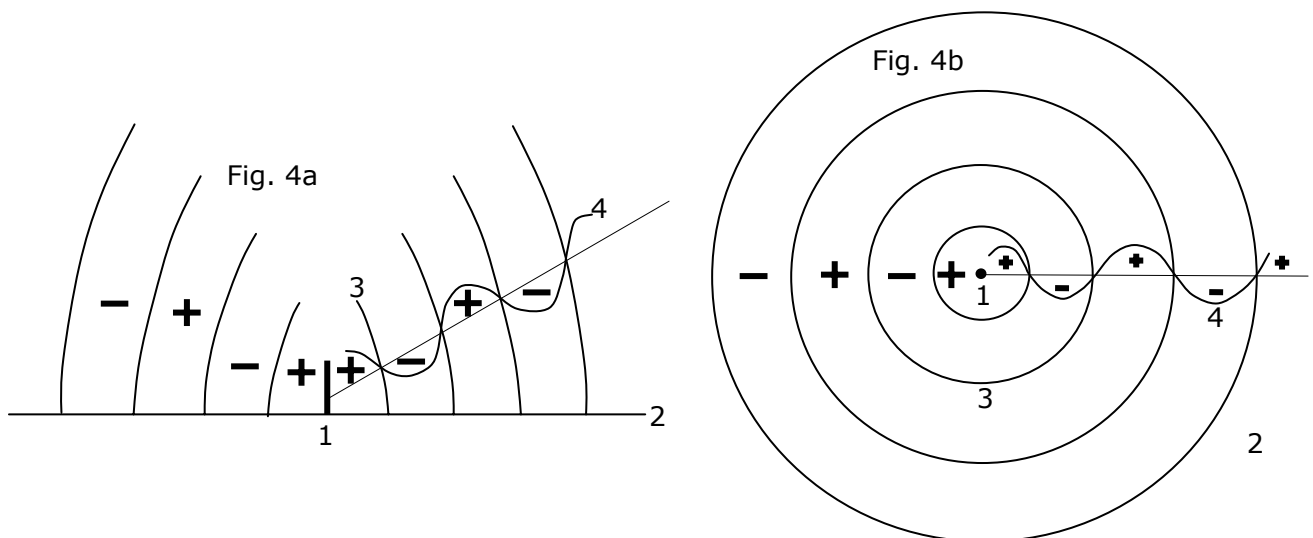

On a figure 4: 1 - antenna, 2 - surface of ground, 3 - line of a zero direction of an electrical field, 4 - graph of a direction of an electrical field in a neutrino (-) and antineutrino (+).

On a figure 5a and 5b the similar picture for horizontal disposition of the antenna of the transmitter is figured.

The vector of an electrical field in a neutrino is side-by-side to antenna and ground.

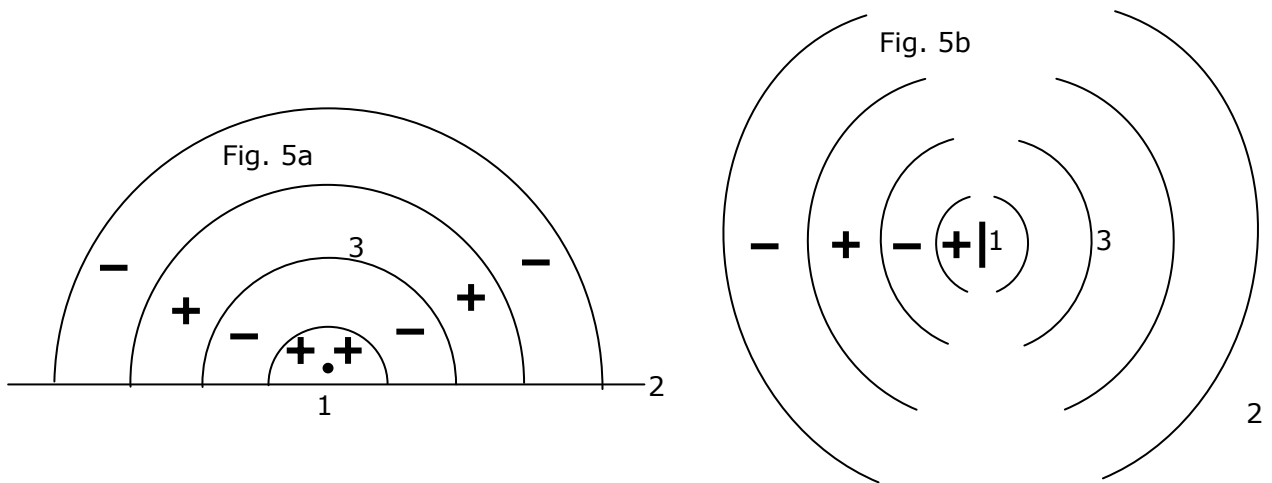

Thus, «electromagnetic radiation» is a Bremsstrahlung, to perpendicular oscillations of electric charges in the antenna and represents following one after another with speed of light neutrino and antineutrino a condition of an electrical field with an opposite direction of this field. It is necessary apart lay emphasis, that inside neutrino and antineutrino of areas of a field nothing oscillates, the value of an electrical field from zero point up to its amplitude value and again up to zero point varies only. The rate of propagation neutrino of radiation is peer to rate of propagation of an electrical field in antenna. As in free space the electrical field is diffused with indefinitely by a high speed, in metal its rate of propagation is less:

$$V = \frac{\infty_V}{\infty_\epsilon} = c \quad (14),$$

where: ∞_V - infinite speed in free space, ∞_ϵ - indefinitely large value of inductivity of metal of the antenna. The ratio of these infinite values gives, in this case, speed of light.

As it is visible from a figure 4 neutrino radiation very similar on radiation of sound waves in air, where the areas increased pressure are interleaved with areas of underpressure of air. Therefore «electromagnetic radiation» represents propagation not cross-sectional, and longitudinal waves. They are introduced us cross-sectional that at interception of the antenna of the receiver in it there are periodic oscillations with an opposite direction of a field for one oscillation period. The supporters of shear waves argue for the stand by the fact of polarization of these waves. However, it is possible to result two counter-evidences. The direction of an electrical field in neutrino radiation coincides with direction field in the antenna, it can be «vertical», «horizontal» and with any arbitrary angle to a horizontal. Besides allowing, that in neutrino areas of radiation nothing oscillates, and neutrino practically have not weight, i.e. by inertia, turn of a polarization plane (conterminous with a plane of an electrical field in a neutrino) to execute very easily by different paths. In remaining, the neutrino wave by nothing differs on properties from other waves (diffraction, interference, reflection, interception etc.). The sound wave is not polarized for the reason that the air pressure is a scalar value, the electrical surge is polarized because the electric field strength is a vector quantity. It is shown on a figure 6 as cross section of a radio wave.

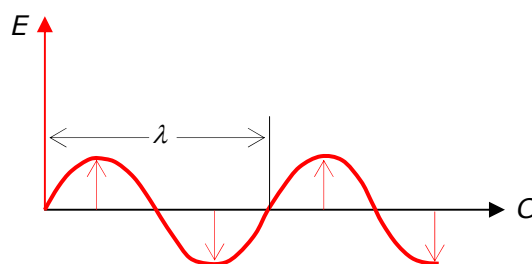

Fig. 6

The neutrino (one halfcycle of a wave), for example, for radio station by power 1000 watt, beaming waves of length 1 km is interesting to count up weight and energy one. For one second the wave will pass spacing interval, numerically equal speeds of light $3 \cdot 10^8$ m. On this spacing interval will lie $6 \cdot 10^5$ neutrinos. Thus, on one the neutrino is necessary energy $1.7 \cdot 10^{-3}$ joules or $1.7 \cdot 10^4$ ergs. Weight a neutrino for this example $1.9 \cdot 10^{-17}$ g. Here, as well as in a microcosmos, the neutrino, having minor weight is capable to transport large energy.

In conclusion of this chapter is necessary to mark an interesting feature in properties the neutrino. Having huge energy, neutrino are easily determined experimentally, on the average range of energies the neutrino practically is impossible to find out because of a unique penetrating power, at energy a neutrino applicable to radio waves they become so large and have such large amplitude, that the electrons in the antenna have time to follow change of an electrical field flying by a neutrinos. Though the form of a photon and motion it for radio waves sharply has changed, but the entity remained former.

Magnetons and magnetonic radiation

As the author completely disclaims the theory of the Maxwell of «electromagnetic radiation», it is necessary to bring some totals of chapter 11.5.1 and all chapters [1], where the problems of originating of photons and their properties were by and large encompassed. The photon radiation presenting flows of separate particles, consisting from a neutrino and antineutrino arises as a Bremsstrahlung, bound with deboosting of an electron motion. As well as all free bodies, photons moves on a right-handed or left-handed trajectory at the expense of gravodynamic self-effect. That the «photon» radiation to make continuous, is necessary on electrons of a conductor to impose a sinusoidally varying electrical field. Thus in space will be beamed alternately neutrino and antineutrino as waves, only not transversal, and longitudinal, similarly to sound, and this problem has found the answer in chapter 11.5.1. Thus, neutrino and antineutrino in a bound condition can exist as separate portions - photons or as continuous radiation (of neutrino - antineutrino radiation, NA-radiation).

Whether only these forms deplete connection a neutrino and antineutrino? I figure, that is not present. At sharp braking of electrons NA-radiation is diffused in a perpendicular direction as a photon or as an sign-variable electrical field, if the electrons are braked in the antenna. But each electron also has also magnetic moment, since represents a frame with an electric current. Earlier was shown, that for a mobile electron it is necessary to distinguish two angular momentum and, accordingly, two magnetic moments. One magnetic moment is connected to screw motion of an electron and is peer to a magneton of the Bohr, and second is connected to an own magnetic moment of an electron and in 137 times less. Is logical to presume, that at sharp braking of an electron the «longitudinal» photons will be beamed, the difference which one from «transversal» is shown on a figure 7.

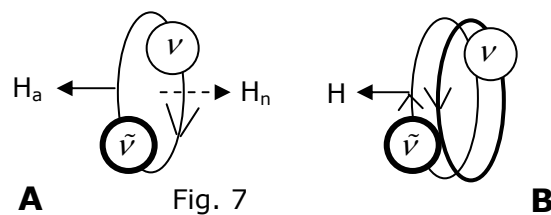

On a figure 7 **A** the «transversal» (customary) photon is shown. Opposite charged neutrino and antineutrino in it moves in one side, therefore their magnetic moments are completely balanced. On a figure 7 **B** the «longitudinal» photon is shown, which one as against «transversal» is more friend to name as a magneton, since it has a uncompensated magnetic moment, directional on or against its motion. At motion of a magneton mean spacing interval between a neutrino and the antineutrino in it is significant less than in a photon, therefore polarization track in environment brakes motion of a magneton (see chapter 23.2 [1]) less. As a consequent, running speed of a magneton and its penetrating power considerably increase. To provoke radiation of magnetons as a solid flow in which one rotated in the counter sides a neutrino and antineutrino moves as a double spiral,

apparently, it is necessary to make so that the radiation started with an axis of a coiled-rod unit.

The new kind of radiation is described by V.I. Korobeynikov in the articles:
New kind of electromagnetic radiation? (<http://n-t.proc.ru/ac/ap.htm#K05>),
Magnet antennas for ultralong radio communication (<http://www.qrz.ru/schemes/contribute/antenns/eh/index.shtml>),
And N.A. Kisel: The EH antennas (<http://www.qrz.ru/schemes/contribute/antenns/eh/ua3aic.shtml>).

Though the authors assert, that investigate new a kind of radiation with properties contradicting of the theory of the Maxwell, the orthodoxes (having a natural allergy to all new) state, that the authors nothing understand in this theory and disclaim their statements by the method tested by orthodoxes, - on the basis of the same theory of the Maxwell, as anything another do not know. I have not got used from a threshold to disclaim new knowledge. Only time who will show, rights. Probably it is the next soap bubble, and probably and is not present. I do not want then to tear the stayed hair on a head, if I pass by possible great discovery.

Great electromagnetic muddle

Gravitational and electrostatic field, despite of apparent analogy between them remain «a white spot» on a map of modern science. It was possible to the Einstein more or is less successful to enter a gravitation in the registry of achievements of a modern physics. However long-term efforts to make same concerning an electrical field were not crowned with success. Therefore orthodox physics has gone by the tested way of substitution of concepts. As soon as there is a necessity of a mention of an electrostatic field at once attention of the reader is transferred to an electromagnetic field. Essentially, the modern physics refuses electrostatic (and magnetic) a field in independent existence, but only jointly in «electromagnetic field». The interplay of electric charges, on notions of official physics, implements an electromagnetic field. It means, that the electrostatic field, smeared-out in space, is substituted by a flow of photons having simultaneously and wave properties. The truth, these «photons» not present, and virtual, i.e. not observed. The light beam on these notions should interact with electrostatic and magnetic deflection yokes and instead of an electronic beam in kinescopes more effective there would be photon beams. However effect of a light deflection is not watched. Is received, that with electrostatic and magnetic field the carriers of electricity can interact only. Finally to complicate the reader, in connection with an electrical field the theory of the Maxwell is indispensable mentioned on the ground that fixed charges does not exist, and driving will forms an electromagnetic field. In the theory of the Maxwell the photons are not mentioned at all, therefore it is time to official physics, at last to clarify itself, lies either Maxwell or quantum theory of a field. As assert orthodoxes, the Compton wavelength demonstrates on what spacing interval the virtual particle from a place of the birth can be eliminated. Thus mass of a photon count to equal zero point, therefore electrostatic field acts on indefinitely large spacing interval. Three errors here are visible at once: at first, mass of a photon is not peer to zero point, and is peer

$$m = \frac{h\nu}{c^2} \quad (15).$$

The rest-mass of a photon is peer to zero point only and not because, that the fixed photon has not mass, and because, that when we attempt it to make fixed, it will vanish. In second, in formula of a Compton wavelength of a particle

$$\lambda_0 = \frac{\hbar}{mc} \quad (16)$$

also enters in term of fraction a particle mass $\hbar = mcr$, therefore reasoning of orthodoxes are erratic. In third, on orthodox definition of virtual particles they are born and here perish to not demonstrate a violation of law of preservation of energy. Therefore to transport interplay on large spacing interval in any way can not. If the virtual particles also could transport interplay on some spacing interval, it is easy to fix outcome of this interplay and

this outcome, by remaining in a system, instead of by vanishing together with virtual particles, again will demonstrate a violation of law of preservation of energy.

Identification of particle fluxes (let and virtual) with the field presenting a substance, spread in space, not correct. Therefore orthodoxes should separately demonstrate, that, for example, gravitational and the electrostatic field is diffused with speed of light. In chapter 11.2.1 [1] is shown, that if the gravitational field is diffused with speed of light, within day the acceleration of gravity should change on 0.398 cm/sec^2 when on sunset we catch up with it, and on dawn we escape from it with speed of 30 kms/sec. The modern equipment allows to meter acceleration of gravity with relative error 10^{-7} - 10^{-9} (Physical encyclopedia under edition A.M. Prohorov, M., 1988, v.1, page 520). Therefore lower boundary of propagation rate of a gravitational field in 10^8 times exceeds speed of light. It is doubtless, that the great electromagnetic muddle has taken place from repeated attempts «to eliminate difficulties» the theories. As a result of similar efforts it is necessary early or late to throw out on a waste tip of a history all agglomerates of orthodoxes concerning theories of fields and interplays.

Electrodynamic paradox

If two like electrical charges rests rather each other, they interact on a Coulomb's law and are repulsed. If these charges will begin to move in one direction, it is an electric current of two conductors and they should be attracted to each other because of magnetic interplay. The paradox even more is sunk and is doubled by that these two charges already move in space together with the Earth, Sun etc. At the same time the experiment demonstrates absence of a magnetic field of superincumbent charges. Within the framework of a modern physics the indicated paradox has not reasonable explanation, that indicates insufficiency of a modern electrodynamics.

New physics easily decides the indicated problem, attracting notion about motion of any free bodies on a screw line. Thus the driving charge is possible to present as the solenoid a magnetic field which one is directed along trajectory of motion, as shown in a figure 8 for positive charges.

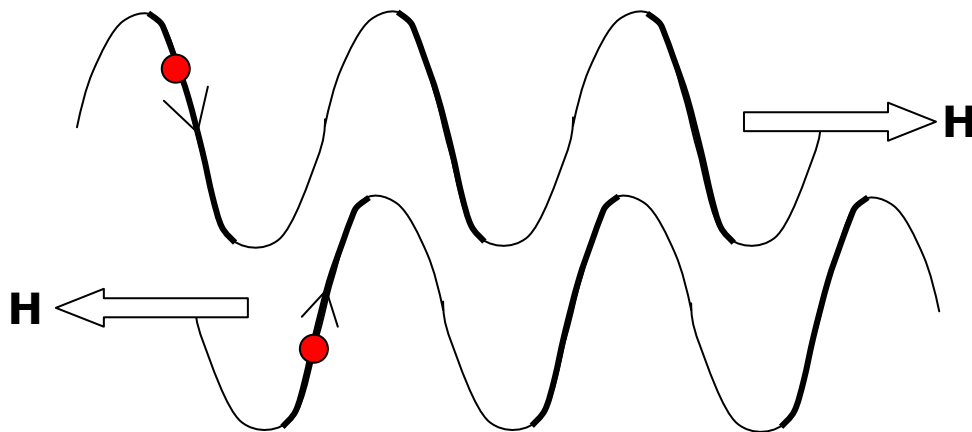

Fig. 8

The direction of an arising magnetic field depends on right-handed or left-handed motion. Thus the «right» and «left» charges will be attracted, and both «right» or both «left» - to be repulsed.

In bundle of charged particles, for example, in the electron-beam tube quantity of the «right» and «left» electrons is approximately identical, therefore their magnetic fields will forms a picture shown arrows on a figure 9. From this figure it is visible, that the bundle is not dispersed in space because of mutual attraction of components compensatory their repulsing.

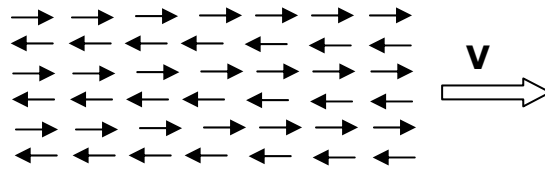

Fig. 9

At transportation motion together with the Earth fixed rather each other charges have not independent motion on a screw line, therefore magnetic fields will not forms. Thus, the double electrodynamic paradox is successfully resolved.

How to capture an electron into atomic orbit

The subject of this chapter has appeared as a result of speculations about experimental endorsements of new physics, the professor Sergey V. Kosianenko from the Petersburg nuclear physics institute for what I to him has sincerely grateful.

On notions of official physics the electron-capture into atomic orbit of any ion is impossible on those to the reasons, which one are indicated for capture of space bodies (see chapter 21 [1]). Therefore official physics does not understand reasons of formation not only neutral atoms, but also any ions. Following the logic of orthodoxes the atom for miscellaneous reasons is capable to lose any electron, but to gain it back any more can not, therefore space should represent a mixture of naked nuclei and mobile electrons, that actually does not take place.

This chapter describes the mechanism of energy loss by an electron in a field of a positive charge up to zero value, then the electron-capture on a parabolic trajectory of atom realizes without problems with the subsequent quantum transition in a ground state (see chapter 13 [1]).

The potential energy of an electron in electrostatic field Ze in a system CGSE is peer:

$$W_p = \frac{Ze^2}{r} \quad (17),$$

it is also universal potential energy of repulsing. Apparently, that before capture this energy should accept zero value. For «dip» of an electron on a positive proton with an end position on orbit of the Bohr (17) gives 27.2 eV. Therefore, before capture the electron should lose on radiation energy 13.6 eV, then its energy before capture will become zero, and after capture and transition in a ground state the electron will lose 13.6 eV. On this example it is possible to formulate a general principle of formation of atoms: the electron from «perpetuity», gaining energy at the expense of attraction to an ion (or positive proton, or to a «naked» nucleus of atom) loses equally as much on radiation in an ionization continuum and before capture has a zero-point energy. Further it will lose still energy applicable to the given potential of ionization to form a steady ion or neutral atom.

What mechanism of this energy loss can be found out on a model system figured on a figure 10 and to confirm experimentally on the similar plant.

Let's presume, that we have constructed electrostatic model of atom of Hydrogenium shown on a figure 10.

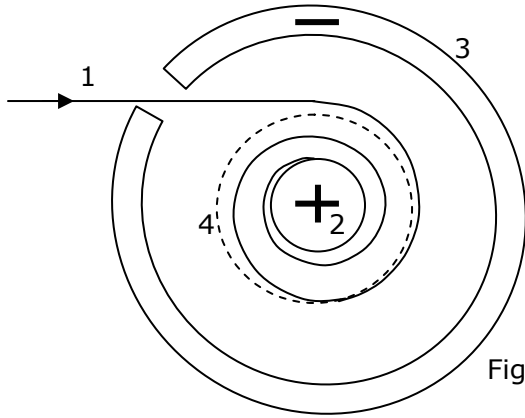

Fig. 10

On a figure 10: 1 - electron beam, 2 - central positive electrode, 3 - outside negatively charged cylindrical ring, 4 - fixed orbit, if was not of energy losses on radiation.

The actual trajectory of electrons will correspond to a solid helical line because of energy losses on radiation. These losses are not connected in any way to notions of orthodox physics about radiation of a particle driving under operating of «centripetal acceleration». They are connected that on the shown trajectory the electrons moves on a screw line and consequently beam at the expense of a Bremsstrahlung, is similar to synchrotron emission with some features. If in model to start an electron beam dispossessed of an angular momentum \hbar («superconducting», «cold»), our model will become in accuracy adequate to atom of Hydrogenium and the electrons will take fixed orbit indicated by a dotted line and at it anything to beam will not be.

For a «cold» electron on fixed orbit the attractive force to a central electrode is peer to centrifugal force of repulsing:

$$\frac{qe}{r^2} = \frac{m_e V^2}{r} \quad (18),$$

where q - charge of an electrode. From (18):

$$r = \frac{qe}{m_e V^2} \quad (19),$$

where: r - radius of fixed orbit.

On a figure 11 the trajectory of an electron on orbit as from above is shown. In the upper half-turn of a screw trajectory component the attractive force to a positive electrode are given to an electron with positive acceleration - radiation is not present. In the lower half-turn same component gives to an electron negative acceleration and there is a Bremsstrahlung because of which one an electron loses energy.

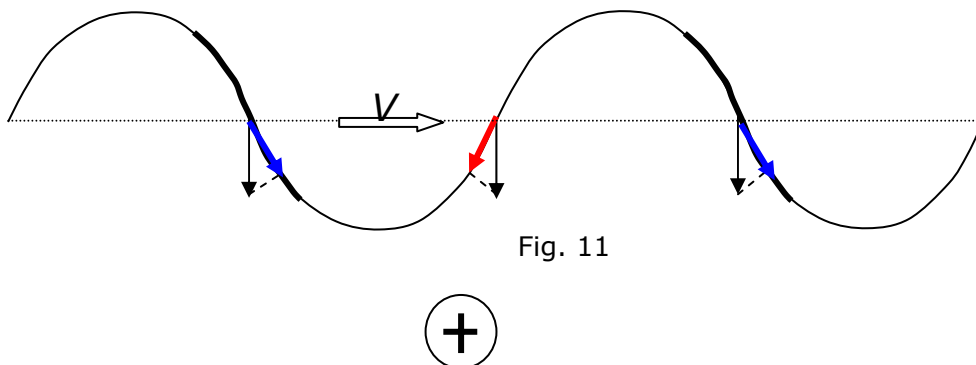

Fig. 11

Allowing equal translational and tangential velocity on a screw trajectory the braking force will be peer:

$$F_b = \frac{qe}{r^2 \sqrt{2}} \quad (20).$$

This force will provokes negative acceleration:

$$a = \frac{\sqrt{2}}{2} \cdot \frac{qe}{m_e r^2} \quad (21).$$

The intensity of a Bremsstrahlung of an electron in a Gaussian system is determined by the formula (B.M. Yavorsky, A.A. Detlaf. The reference book on physics. Moscow, «Science», 1964, page 529):

$$I = \frac{2e^2 a^2}{3c^3} \quad (22),$$

where: c - speed of light. By substituting (20) in (21), we shall discover:

$$I = \frac{q^2 e^4}{3c^3 m_e^2 r^4} \quad (23),$$

whence it is possible to draw a conclusion, that the emission power very much sharply is augmented in process of nearing an electron to positive electrode, and for a massive particle (for example, positive proton) it would be in 3.4 million time less.

Investigating a spectrum of continuous radiation on the shown model system at miscellaneous values of an electrostatic field between electrodes and comparing it with an ionization continuum of miscellaneous areas of space, we could identify ions of any atoms and their concentration. In earth conditions is much more lighter to conduct the similar analysis on radiation of matter in an ionized condition.

The interesting feature of the shown apparatus is, that is possible to study radiation of a separate electron. This radiation consists of separate photons on each half-turn of a screw trajectory and to this tag it is possible experimentally to confirm the set up theory of «electrostatic» radiation and at the same time motion of microparticles on a screw line.

Paradox of the Maxwell

Under the theory of the Maxwell in a node of an electromagnetic wave of tension electrical and the magnetic fields simultaneously receive zero values. That the oscillations were prolonged, any elastic medium («ether») is necessary, which one in this moment discharges the stress. Differently we contradict an energy conservation law, in a node of an electromagnetic wave it without leaving a trace fades and newly arises from anything. On a figure 12 this situation is shown.

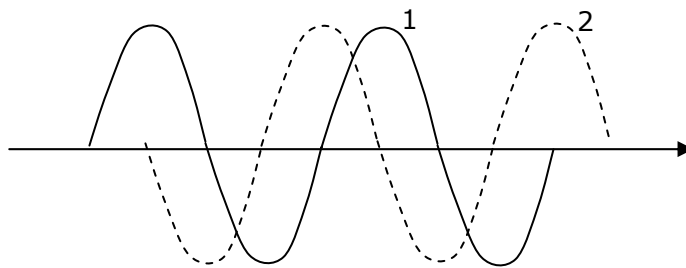

Fig. 12

Digit 1 indicates change of an electric field density (change of magnetic density same in a perpendicular direction), digit 2 shown a stress of «ether» (if it existed). At a zero electric field density the elastic stress of «ether» is maximum and on the contrary. The propagation of any wave is a series entrainment in process of material particles of space. If the particles participating in wave process do not interact with each other, they can not provoke the neighbours to share in a wave propagation, and if these particles among themselves interact, fast will lose energy on internal friction and the wave propagation on large spacing interval will become impossible. The experimental data confirm transfer of electromagnetic waves on space spacing intervals, therefore, disclaim presence of any oscillations in an electromagnetic wave.

The second party of a paradox of the Maxwell is, that we easily allocate in uncountable electromagnetic waves the radio station, necessary to us. However under the theory of the Maxwell any change of an electrical field in the given point of space causes change of a

magnetic field and on the contrary. As in the given point of space huge quantity electrical and magnetic fields changes, their change under the theory of the Maxwell should cause certain general electrical or magnetic field the parents which one in an equal measure are all fields, therefore signals of radio stations should irreversibly be blended and radio communication will become impossible.

In new physics the paradox of the Maxwell does not arise. That by itself «electromagnetic wave» introduces is particularized in chapter 11.5.1 [1].

References:

1 <http://www.new-physics.narod.ru>